

WELCOME

Thank you for buying this Segway, Segway OFF-road vehicles will bring you a new driving experience.

For your driving safety, you must read this manual before riding. This manual contains a large number of safety instructions, operation instructions, maintenance instructions and safety warnings.

A careful reading of this manual will help you to quickly understand the vehicle and your full driving to help.

Periodic maintenance procedures are included in this manual and are performed regularly to assist in your vehicle safety.

⚠ WARNING
Read, understand, and follow all of the instructions and safety precautions in this manual and all product labels.
Failure to follow the safety precautions could result in serious injury or death.

IMPORTANT NOTICE

This vehicle is designed and manufactured for off-road use and complies with all applicable off-road noise, vibration and emission regulations.

Before driving the vehicle, please understand the local laws and regulations, choose the allowed road driving, abide by the local traffic regulations.

This manual is applicable to the ATV fuel series and describes all equipment including optional components. Therefore, some of the optional equipment described in the manual may be not installed on your vehicle.

All specifications provided in this manual are up to date at the time of printing. However, due to continuous product improvement, the contents of this manual will be updated at any time without prior notice. The descriptions and/or procedures in this publication are for informational purposes only. Take no responsibility for omissions or inaccuracies. Express prohibition or reuse of descriptions and/or programs contained in whole or in part.

If your vehicle needs any service and repair matters, please contact our dealer, our dealer will provide satisfactory service in a timely manner.

Login on <http://powersports.segway.com> query the nearest Segway dealer or service locations.

TABLE OF CONTENTS

SAFETY INTRODUCTION	1
VEHICLE DEVICE	23
OPERATION	65
MAINTENANCE	97
SPECIFICATIONS	168
TROUBLESHOOTING	176
EMISSION CONTROL SYSTEM	186
WARRANTY	189

INTRODUCTION

BEFORE YOU RIDE

This SEGWAY vehicle is an off-road vehicle. Familiarize yourself with all laws and regulations concerning the operation of this vehicle in your area.

WARNING

- ◆ Failure to heed the warnings and safety precautions contained in this manual can result in severe injury or death. Your SEGWAY vehicle is not a toy and can be hazardous to operate. This vehicle handles differently than cars, trucks or other off-road vehicles. A collision or rollover can occur quickly, even during routine maneuvers like turning, or driving on hills or over obstacles, if you fail to take proper precautions.
- ◆ Read this owner's manual that came with your vehicle. Understand all safety warnings, precautions and operating procedures before operating the vehicle. Keep this manual with the vehicle.
- ◆ Never operate this vehicle without proper instruction. Take an authorized training course. See the Safety Training section for more information.

- ◆ This vehicle is an ADULT VEHICLE ONLY .You MUST be at least age 16 and have a valid driver's license to operate this vehicle.
- ◆ Always use the cab nets (or doors) while riding in this vehicle. Always keep hands, feet and all other body parts inside the vehicle at all times.
- ◆ Always wear a helmet, eye protection, gloves, long-sleeve shirt, long pants and over-the-ankle boots.
- ◆ Never operate this vehicle under the influence of drugs or alcohol, as these conditions impair judgement and reduce the operator's ability to react.
- ◆ Complete the New Operator Driving Procedures outlined this manual Never allow a guest to operate this vehicle until the guest has completed the New Operator Driving Procedures.
- ◆ Never permit a guest to operate this vehicle unless the guest has reviewed the owner's manual and all safety labels and has completed a safety training.

The meaning of these signs:

WARNING

WARNING indicates a hazardous situation which, if not avoided, could result in death or serious injury.

CAUTION

CAUTION, used with the safety alert symbol, indicates a hazardous situation which, if not avoided, could result in minor or moderate injury.

NOTICE

NOTICE is used to address practices not related to personal injury.

IMPORTANT

IMPORTANT provides key reminders during disassembly, assembly, and inspection of components.

The Prohibition Safety Sign indicates an action NOT to take in order to avoid a hazard.



The Mandatory Action Sign indicates an action that NEEDS to be taken to avoid a hazard.



SAFETY INTRODUCTION

WARNING LABELS.....	3
SPECIAL SAFETY MESSAGES.....	10
IMPORTANT SAFETY INFORMATION.....	14
Reading the manual.....	14
Safe driving age.....	15
Riding equipment.....	16
Using alcohol or drugs.....	18
Vehicle modification.....	19
Passengers.....	20
Contact with exhaust.....	21
Fuel safety.....	22

SAFETY INTRODUCTION

SEGWAY

Failure to follow the warnings and safety precautions in this manual may result in serious injury or death. It can be dangerous to operate an ATV that is not regulated and is driven differently from other vehicles, such as motorcycles and automobiles. If proper precautions are not taken, a collision or rolled-over may occur during normal maneuvers such as turning, climbing, or overcoming obstacles. Understand all safety warnings, precautions and operating procedures before operating the vehicle. Bring this manual with you.

WARNING LABELS

Warning labels have been placed on the vehicle for your protection. Read and follow the instructions on the labels carefully. If any of the labels depicted in this manual differ from the labels on your vehicle, always read and follow the instructions on the vehicle. If any label becomes illegible or comes off, contact Segway Powersports to obtain a replacement.

SAFETY INTRODUCTION

SEGWAY

Variant/Version: SGW570F-A3

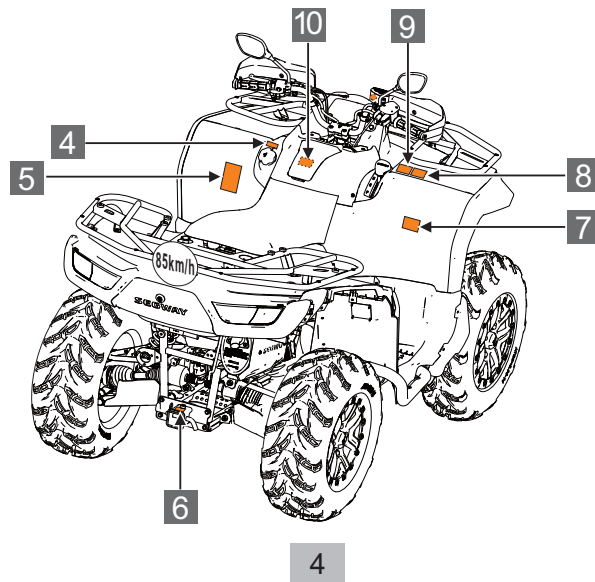
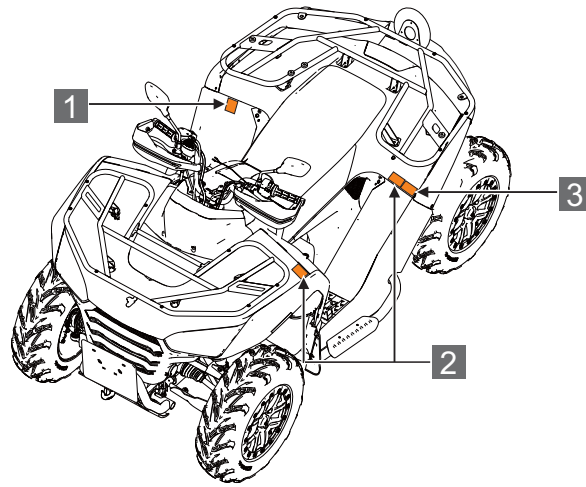

Variant/Version: SGW570F-A6

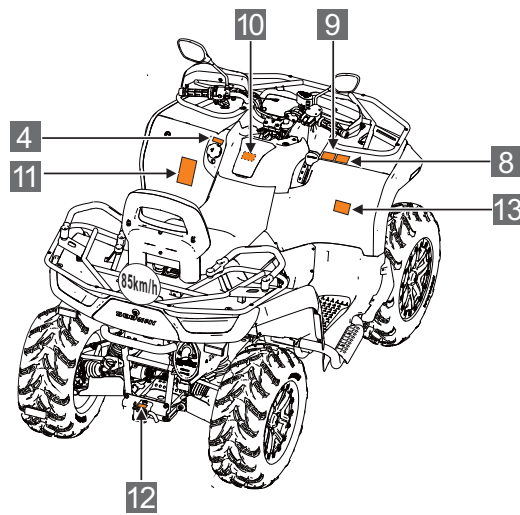
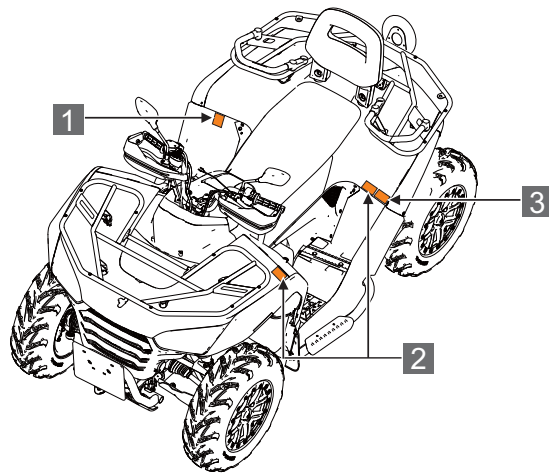

1



2

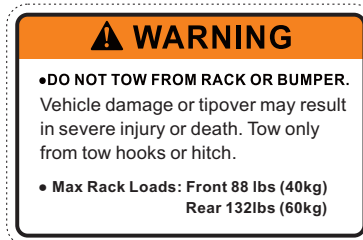

3

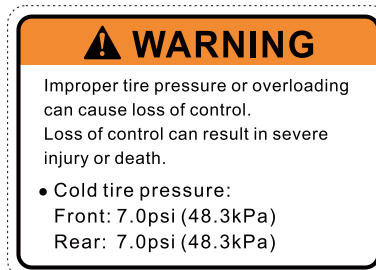

4



5

⚠ WARNING

Improper ATV use can result in **SEVERE INJURY** or **DEATH**.



ALWAYS USE AN APPROVED HELMET AND PROTECTIVE GEAR



NEVER CARRY PASSENGERS



NEVER USE WITH DRUGS OR ALCOHOL

NEVER operate:

- Without proper training or instruction.
- At speeds too fast for your skills or the conditions.
- On public roads-a collision can occur with another vehicle.
- With a passenger-passengers affect balance and steering and increase risk of losing control.

ALWAYS:

- Use proper riding techniques to avoid vehicle overturns on hills and rough terrain and in turns.
- Avoid paved surfaces-pavement may seriously affect handling and control.

LOCATE AND READ OWNER'S MANUAL. FOLLOW ALL INSTRUCTIONS AND WARNINGS

6

⚠ WARNING

Improperly loading a trailer may cause loss of control. Evenly balance the load.

- Maximum unbraked towing mass 300 kg (662 lb)
- Maximum unbraked tongue mass 100 kg (220 lb)
- Maximum inertia-braked towing mass 400 kg (882 lb)
- Maximum inertia-braked tongue mass 100 kg (220 lb)

7

⚠ WARNING

 **NEVER** ride as a passenger.
Passengers can cause a loss of control, resulting in SEVERE INJURY OR DEATH.

8

⚠ WARNING

Turning the vehicle in 4WD-LOCK ("DIFF.LOCK") takes more effort.
Operate at a slow speed and allow extra time and distance for maneuvers to avoid loss of control.

9

⚠ WARNING

- Step on the brake pedal each time the gear is changed.
- When the ATV is unmanned, the transmission must be placed in parking gear.

10

CAUTION

The air filter must be maintained in accordance with the requirements of the Segway «Owner's Manual» otherwise it may seriously damage your engine.

11

⚠ WARNING

Improper ATV use can result in SEVERE INJURY or DEATH.



ALWAYS USE AN APPROVED HELMET AND PROTECTIVE GEAR



NEVER CARRY MORE THAN 1 PASSENGER



NEVER USE WITH DRUGS OR ALCOHOL

NEVER operate:

- Without proper training or instruction.
- At speeds too fast for your skills or the conditions.
- On public roads-a collision can occur with another vehicle.

ALWAYS:

- Use proper riding techniques to avoid vehicle overturns on hills and rough terrain and in turns.
- Avoid paved surfaces-pavement may seriously affect handling and control.

LOCATE AND READ OWNER'S MANUAL.
FOLLOW ALL INSTRUCTIONS AND WARNINGS

12

⚠ WARNING

Improperly loading a trailer may cause loss of control. Evenly balance the load.

- Maximum unbraked towing mass 350 kg (771 lb)
- Maximum unbraked tongue mass 100 kg (220 lb)
- Maximum inertibraked towing mass 400 kg (882 lb)
- Maximum inertibraked tongue mass 100 kg (220 lb)

13

⚠ WARNING



Passengers under 12 are prohibited. Passenger should be well seated & hold tight the handgrip during public road operation.



Passenger seat could be used during public roads operation. Passenger seat shall not be used during field operation.

SPECIAL SAFETY MESSAGES

SEVERE INJURY OR DEATH can result if you do not follow these instructions:

- ◆ The minimum recommended driving age for this vehicle is 16 years.
- ◆ Never operate this vehicle without wearing an approved motorcycle helmet that fits properly. You should also wear eye protection (goggles or a face shield), gloves, over-the-ankle boots, long-sleeved shirt or jacket, and long pants.
- ◆ Never consume alcohol or drugs before or while operating this vehicle.
- ◆ Never attempt jumps or other stunts.
- ◆ Never operate at speeds too fast for your skills or the conditions. Always go at a speed that is proper for the terrain, visibility, operating conditions, and your experience.
- ◆ Always inspect your vehicle each time you use it to be sure it is in safe operating condition.
- ◆ Never operate on excessively rough, slippery, or loose terrain until you have learned and practiced the skills necessary to control the vehicle on such terrain. Always be especially cautious on these kinds of terrain.
- ◆ Always follow the inspection and maintenance procedures and schedules described in this manual.
- ◆ Never operate on hills that are slippery or ones where

you will not be able to see far enough ahead of you. Never go over the top of a hill at speed if you cannot see what is on other side.

- ◆ Always keep both hands, arms, feet, and legs inside the vehicle at all times during operation. Keep your feet on the floorboard. Never hold onto the enclosure. Otherwise, your hands could be injured if it is caught between the enclosure and an obstacle outside the vehicle.
- ◆ Always keep both hands on the steering wheel when driving.
- ◆ Always go slowly and be extra careful when operating on unfamiliar terrain. Always be alert to changing terrain conditions when driving the vehicle.
- ◆ Never wrap your thumbs and fingers around the steering wheel. This is particularly important when driving in rough terrain. The front wheels will move right and left as they respond to the terrain, and this movement will be felt in the steering wheel. A sudden jolt could wrench the steering wheel around, and your thumbs or fingers could be injured if they are in the way of the steering wheel spokes.
- ◆ Never turn at excessive speed. Practice turning at slow speeds before attempting to turn at faster speeds. Do not attempt turns on steep inclines.
- ◆ Always follow proper procedures for going uphill. If you lose control and cannot continue up a hill, back down the hill with the engine in reverse gear. Use engine

SAFETY INTRODUCTION

SEGWAY

braking to help you go slowly. If necessary, use the brakes gradually to help you go slowly.

- ◆ Never operate the vehicle on hills that are too steep for it or for your abilities. Go straight up and down hills where possible.
- ◆ Never operate the vehicle in fast flowing water or water deeper than the floorboards on this model. Remember that wet brakes may have reduced stopping ability. Test your brakes after leaving water. If necessary, apply the brake several times to let friction dry out the linings.
- ◆ Always be sure there are no obstacles or people behind you when you operate in reverse. When it is safe to proceed in reverse, go slowly.
- ◆ Always check terrain before going down hills. Go as slowly as possible. Never go down a hill at high speed.
- ◆ Always check for obstacles before operating in a new area.
- ◆ Do not brake abruptly when carrying loads in the cargo bed.
- ◆ Always use the size and type of tires specified in this manual.
- ◆ Always maintain proper tire pressure as described in this manual.
- ◆ Never exceed the stated load capacity. Cargo should be as far forward in the bed as possible, and distributed evenly from side to side. Be sure cargo is secured so that it cannot move around during operation.

Reduce speed and follow instructions in this manual for carrying cargo or pulling a trailer. Allow greater distance for braking.

- ◆ Brake discs can be over-heated after continuous braking. Allow brake disc to cool before serving.
- ◆ Risks related to contact with hot surfaces, including residual risks such as filling of oil or coolant hot engines or transmissions.

IMPORTANT SAFETY INFORMATION

Reading the manual

⚠ WARNING

Driving an ATV improperly increases the risk of accidents. The driver must know how to drive the vehicle correctly in different situations and on different terrain.

Before driving the vehicle, all drivers must complete the required driving safety training. Please ensure that each driver has read this manual and all product warning labels and has passed the safety training course. Otherwise, the vehicle will not be allowed to drive.



Safe driving age

WARNING

The minimum recommended driving age for this vehicle is 16 years. Children under the age of 16 must not drive this vehicle. Not to drive the vehicle without proper driving training; Training courses are required. Please ensure that each driver has read this manual and all product labels and has completed a safety training course for anyone who is not allowed to drive the vehicle.



Riding equipment

WARNING

For your safety, we strongly recommend that you always wear an approved motorcycle, eye protection, boots, gloves, long pants, and a long-sleeved shirt or jacket whenever you ride.

Although complete protection is not possible, wearing proper gear can reduce the chance of injury when you ride.

Helmet

Wearing a helmet can prevent head injuries. At all times, you must wear a helmet that meets basic safety standards when driving. Both U. S. and Canadian qualified helmets bear a U. S. Department of Transportation label. ECE 22.05 marks are available in Europe, Asia and Oceania. The ECE mark consists of a circle around the letter E, followed by the approved area codes for different countries. The approval number and serial number are also displayed in the label.

Additional Riding Gear

Sturdy off-road motorcycle boots to help protect your feet, ankles, and lower legs.

Off-road motorcycle gloves to help protect your hands.

Riding pants with knee and hip pads, a riding jersey with padded elbows, and a chest/shoulder protector.

⚠ WARNING

Driving ATV after drinking or taking drugs may adversely affect a driver's judgment, reaction time, balance, and feelings. Do not drink alcohol or take drugs before or during driving.

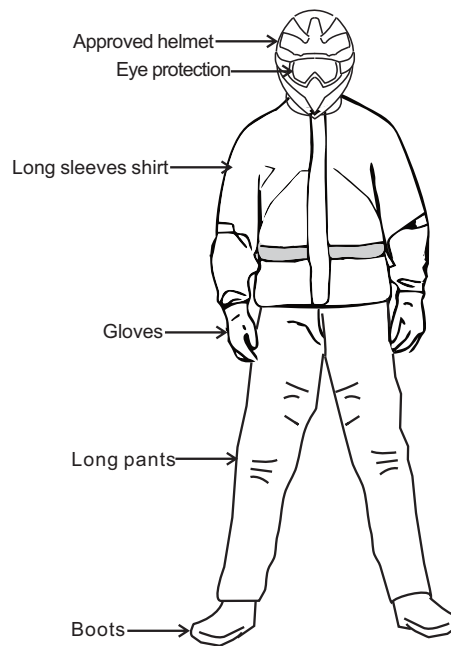

Using alcohol or drugs

WARNING

Operating this vehicle after consuming alcohol or drugs could adversely affect operator judgment, reaction time, balance and perception.

Never consume alcohol or drugs before or while operating this vehicle.



Vehicle modification

WARNING

We strongly recommend that consumers do not attempt to increase vehicle speed or use any equipment that increases the power of the vehicle. If any equipment is added to the vehicle, or if any modifications are made to the vehicle to increase the vehicle speed or power, the all-terrain vehicle warranty is terminated. The addition of certain parts may change the handling of the vehicle, including (but not limited to) mowers, sledges, tires, sprayers, or large luggage racks.



Passengers

⚠ WARNING

Picking up passengers severely reduces a driver's ability to balance and control ATVs, which can lead to accidents or rollovers. Driving ATV should not exceed the number of passengers required by the vehicle.

SGW570F-A3
Never carry passengers

SGW570F-A6
Rated capacity: 1 person



Contact with exhaust

WARNING

Engine exhaust is toxic and can cause loss of consciousness or death in a short time. Do not start or run a motor in a closed space. The engine exhaust of this product contains chemicals that cause cancer, birth defects or other reproductive damage, and you can only drive it outside the room or in a well-ventilated place



Fuel safety

WARNING

Gasoline is very flammable under certain conditions

- ◆ You must be extremely careful when dealing with gasoline.
- ◆ When refueling, the engine must be shut off and must be done outdoors or in a well-ventilated area.
- ◆ At or near the refueling or gasoline storage place. No smoking, no open flames or sparks.
- ◆ Do not overflow when refueling. Do not fill the tank to the neck.
- ◆ If gasoline gets on your skin or clothes, wash them with soap and water immediately and change clothes.

VEHICLE DEVICE

VEHICLE ACTIVATION.....	25
Vehicle unlocked.....	27
APP FUNCTION.....	28
PARTS AND CONTROL.....	29
Parts localization.....	29
Handlebar switch.....	30
Ignition lock.....	31
Engine start/stop switch.....	32
The headlight switch.....	33
Left right steering switch.....	34
Emergency switch.....	35
Force-multiplier switch.....	36
Winch switch.....	37
Toggle switch for Two-wheel drive or Four-wheel drive.....	38
Accelerator.....	40
Standby power output seat.....	41
Shift institutions	42

VEHICLE DEVICE

Parking brake.....	43
Parking brake lever free clearance.....	44
Foot brake.....	45
Auxiliary brake.....	47
Fuel tank cap.....	48
Storage box.....	49
INSTRUMENT PARTS.....	50
Instrument indicator light/warning light.....	51
Instrument information display area.....	54
Diagnostic displays code definitions.....	57
Screen Function Setting.....	63
HANDLEBAR ADJUSTMENT.....	64

VEHICLE ACTIVATION

This vehicle is equipped with vehicle DTS system for you. DTS is used to communicate with background system and mobile APP, so as to obtain vehicle information and control vehicle with mobile APP. This is an optional system. In order to make you quickly familiar with and use the system, please read the user's manual carefully, understand the relevant operation and use information.

NOTICE

The new vehicle must be activated on the APP for the first time if equipped with vehicle DTS, otherwise the engine will not start.

IOS mobile phone search “**Segway powersports**” to download application from “APP STORE” , Android mobile phone first download "Google play", and then search “**Segway powersports**” to download application in Google Play.

After the successful installation of the APP, the vehicle will be registered and activated. Firstly, find the VIN code on the vehicle and register on the APP. The registration procedure is as follows:

1. Power on the vehicle with the mechanical key;

Input or scan vehicle VIN code according to APP registration prompts, and step on the vehicle brake at the same time. The VIN barcode is located under the seat cushion. Note:

VEHICLE DEVICE

SEGWAY

The vehicle identification code may not be scanned due to the influence of light. You can try to enter the VIN code manually. The vehicle VIN code is either on the vehicle frame (see Page 171) or on the vehicle nameplate (see Page 172).

2. Click the confirm button to complete the vehicle binding operation.
3. Click to start the vehicle.

Unlock Vehicle

There are three ways to unlock a vehicle:

1. Mechanical key (preferred).

2. APP remote unlock vehicle

APP Remote Unlock is based on 4G network. As long as the area covered by the network, you can use the remote unlock function in the APP to power the vehicle.

3. APP Bluetooth unlock vehicle

When both the vehicle and the mobile phone are on, within the effective connection distance of the Bluetooth signal, the vehicle Bluetooth module will automatically unlock the vehicle after acquiring the mobile phone Bluetooth signal, and automatically lock the vehicle when the mobile phone is far away.

NOTICE

After using the mechanical key to power down, the vehicle cannot be unlocked by induction to power up again. It needs to disconnect the reconnection and close the unlock to restart.

Mechanical key unlock is the optimal unlock method for vehicles. If you do not want to use the sensor unlock function, the sensor unlock setting can be turned off in the APP.

APP FUNCTION

This app is a program designed for users who have the Segway vehicle.

Main features: driving control analysis, vehicle data analysis...

Detail information pls see APP User Manual.

PARTS AND CONTROL

Parts localization

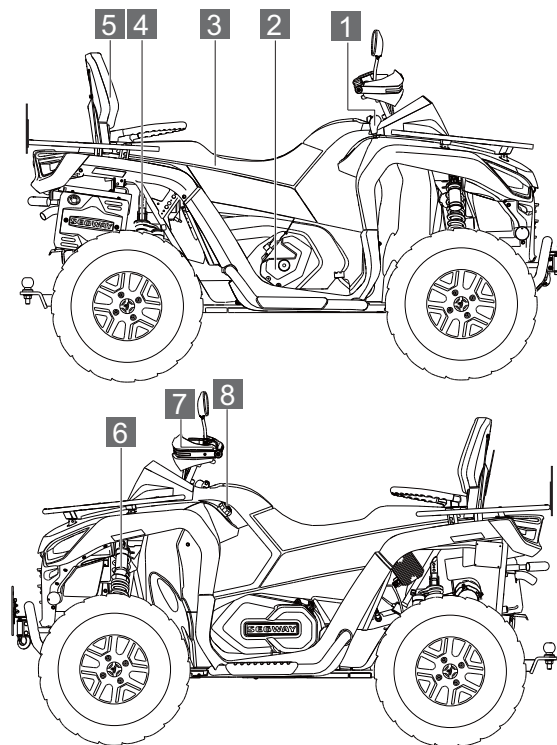

- | | | |
|---------------------------|----------------------|-------------------------|
| 1 Shift Level | 2 Engine | 3 Cushion |
| 4 Rear Absorber | 5 Backrest | 6 Front Absorber |
| 7 Handlebar Switch | 8 Fuel filler | |

Handlebar switch

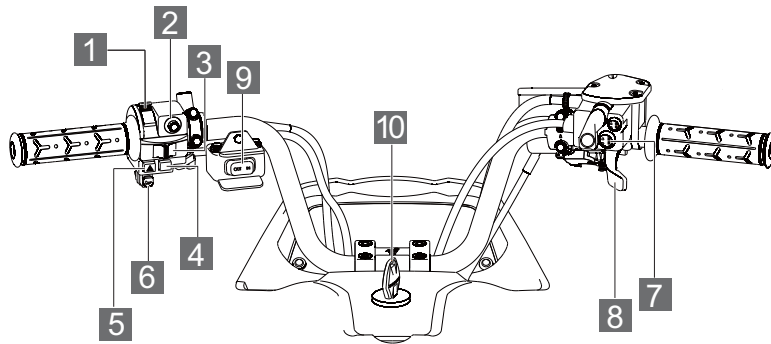

- | | |
|---------------------------|------------------------------|
| 1 Headlight Switch | 2 Engine Start Switch |
| 3 Steering Switch | 4 Engine Stop Switch |
| 5 Emergency Switch | 6 Horn Switch |
| 7 2/4 WD Switch | 8 Accelerator |
| 9 Winch Switch | 10 Ignition Lock |

Ignition lock

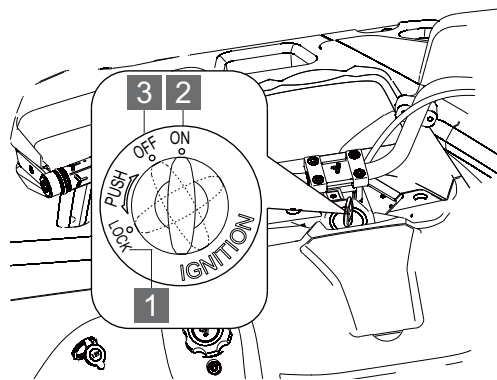

- 1 Steering Lock** **2 Power On** **3 Power Off**

The ignition lock is located in the central zone of the handlebars.

Turn the key to position “ LOCK ”: Lock the rotation direction of the vehicle, so that the vehicle direction in a fixed position.

Turn the key to position “ ON ” : Vehicle is power on, the vehicle’s electrical components can be worked.

Turn the key to position “ OFF ” : Vehicle is power off, When the switch is in the off position, the key can be removed from the switch.

To joint the motor starter by turn the key to start location.

Engine start/stop switch

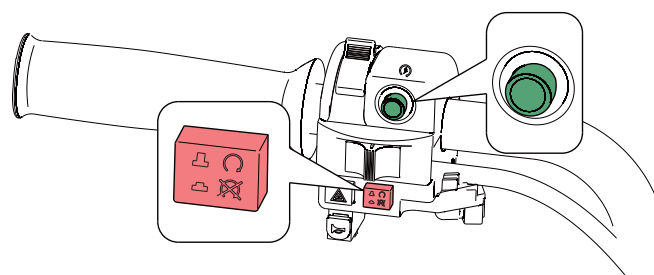

1 Engine start button (Green)

2 Engine stop button (Red)

Vehicle launch

1. Tighten the foot brake;

Turn the ignition key into " ON " position.(see page 31)

2. press the engine start button (green), the engine start;

The vehicle stop

Press the engine stop button (red) to stop the engine.

The headlight switch

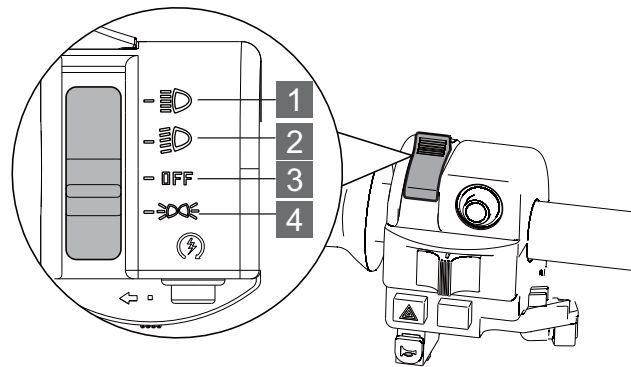

This switch is a light switch. The corresponding position corresponds to different light modes.

1 High beam mode

Turn on the vehicle high beam mode and the "  " sign on the instrument will be lit;

2 Low beam mode

Turn on the vehicle low beam in the mode of low beam;

3 Light off mode

4 Position light mode

Position light mode: Turn on the vehicle position light, and the "  " sign on the instrument is lit;

When the ignition lock is in the "ON" position, push the switch to the desired mode position, and to turn OFF the light, push the switch to the " OFF " position.

Left right steering switch

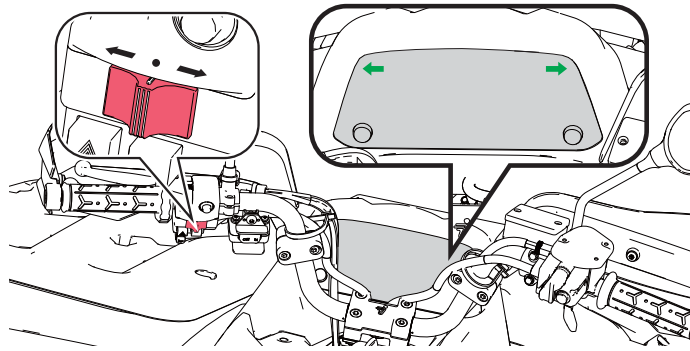

- ← Switch Slide to the left, left turn signal on. At this point, the " ← " chart of the meter is brightly punctuated.
- Switch slides to the right, right turn signal on. At this point, the " → " chart of the meter is brightly punctuated.
- Turn off the turn signal in the middle position.

Emergency switch

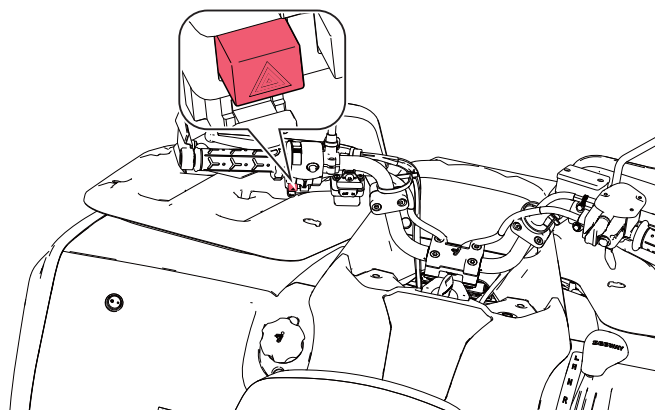



Use this switch in case of emergency, press the switch to start, and press stop again. The vehicle position light flashes when the emergency switch is on.

- ◆ **Temporary parking of vehicles;**
- ◆ **Failure of the vehicle;**
- ◆ **When the vehicle encounters other emergencies;**

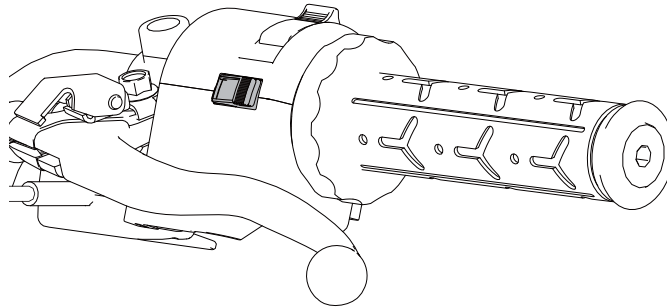
Force-multiplier switch



When the vehicle on 4WD (instrument shows 4WD symbol “”, for details see page 39) or 4WD locked (instrument shows 4WD locked symbol “”, for details see page 39), If the vehicle is underpowered due to muddy conditions, mountainous conditions and vehicle in troubles, you can keep holding press this switch, the vehicle will lift the speed limit and enhance the power, it maybe help you out of trouble.

Winch switch

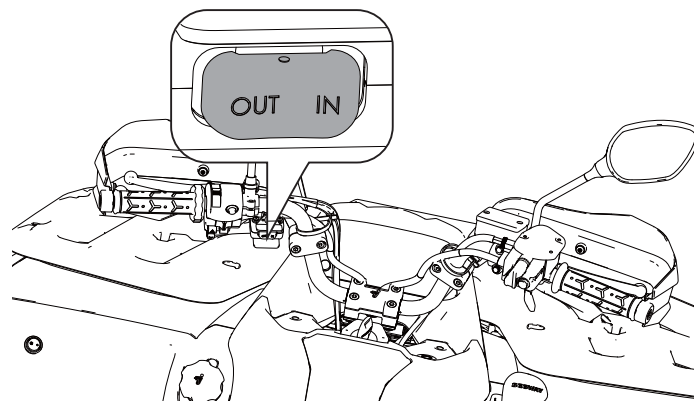

OUT: Release the winch wire rope







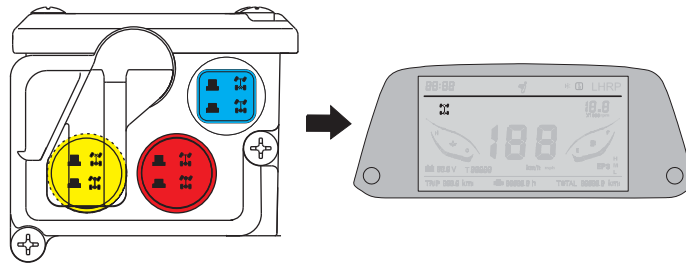

IN: Retract the winch wire rope

Winch is used to drag and drop the load, understand the correct use of capstan steps and methods, pay attention to the use of safety matters, please refer to the winch instructions and matters needing attention (see page 91)

Toggle switch for Two-wheel drive or Four-wheel drive



Key operation	Instrument Icon	Mode	Definition of mode state
Real axle differential			
Blue button pressed, Red button pops up		2 x 4 patterns	When the two-four-wheel drive switch is in the two-wheel drive state, the whole vehicle is only driven by the rear wheel, and the front wheel has no power output. The meter shows the symbol " " for the second drive. This mode is suitable for vehicles driving on flat roads.
Blue button pressed, Red button pressed		4 x 4 patterns	When the two-four-wheel drive switch (4-wheel drive switch) is pressed, the symbol " " of 4-wheel drive is displayed on the instrument. At this time, the instrument is in the state of 4-wheel drive, with power output of the front wheel and power output of the rear wheel. This mode is suitable for muddy conditions, mountainous conditions and other bad road conditions.

<p>Blue button pressed, Yellow button pops up</p>		<p>4x4 locking mode</p>	<p>When the two-four-wheel drive switch (4-wheel drive switch) is pressed, the four-wheel drive lock symbol "  " is displayed on the instrument. At this time, the four-wheel drive lock is working in the state of 4-wheel drive lock. The front wheel has power output, the rear wheel has power output, and the left and right tires of the front wheel output the same speed and power. The vehicle will in speed limitation and speed cannot more than 30km/h, this mode is suitable for vehicle in troubles.</p>
<p>Rear axle locking</p>			
<p>Blue button pops up, Red button pops up</p>		<p>2 x 4 patterns</p>	<p>When the two-four-wheel drive switch is in the two-wheel drive state, the whole vehicle is only driven by the rear wheel, and the front wheel has no power output. The meter shows the symbol "  " for the second drive. This mode is suitable for vehicles driving on flat roads.</p>
<p>Blue button pops up, Red button pressed</p>		<p>4 x 4 patterns</p>	<p>When the two-four-wheel drive switch (4-wheel drive switch) is pressed, the symbol "  " of 4-wheel drive is displayed on the instrument. At this time, the instrument is in the state of 4-wheel drive, with power output of the front wheel and power output of the rear wheel. This mode is suitable for muddy conditions, mountainous conditions and other bad road conditions.</p>
<p>Blue button pops up, Yellow button pops up</p>		<p>4x4 locking mode</p>	<p>When the two-four-wheel drive switch (4-wheel drive switch) is pressed, the four-wheel drive lock symbol "  " is displayed on the instrument. At this time, the four-wheel drive lock is working in the state of 4-wheel drive lock. The front wheel has power output, the rear wheel has power output, and the left and right tires of the rear wheel output the same speed and power. The vehicle will in speed limitation and speed cannot more than 30km/h, this mode is suitable for vehicle in troubles.</p>

Accelerator

Accelerator control engine speed, to increase the engine speed, use your thumb to press the Accelerator, to reduce the engine speed, release the Accelerator pressure, when you release the thumb, the engine back to idle.

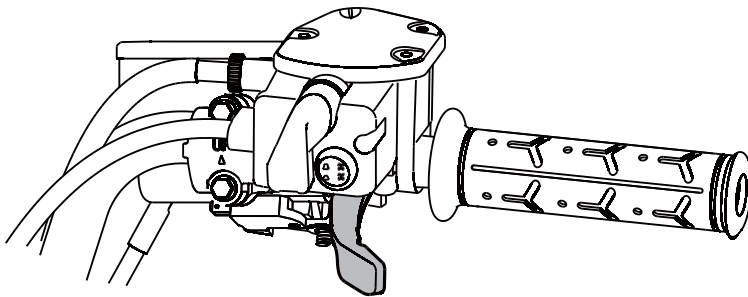

Accelerator

⚠ WARNING

Check whether the accelerator is normal before driving. If the accelerator is stuck or not working properly, it will cause an accident. If the accelerator is stuck or not working properly, you are prohibited to start or drive the vehicle.

Standby power output seat

Power sockets are available for 12V accessories with operating current less than 10A .

The vehicle is equipped with two 12VDC ports.

Output power: 12V

Left: USB port

Right: Cigarette lighter

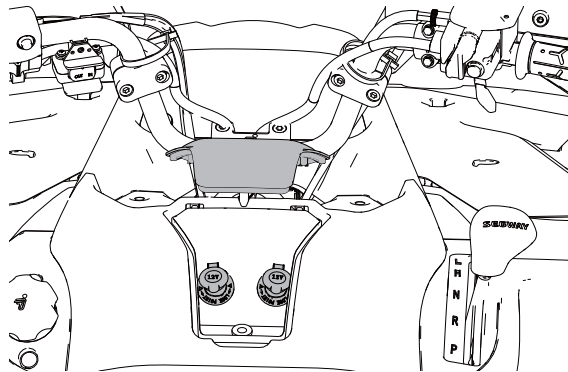

Open the lid

Service conditions of power sockets:

Place the ignition key in " ON " mode.

Shift institutions

Different operation modes correspond to different gear. After selecting the gear, check the indicator light on the instrument panel to ensure that the gear has been switched to the desired position. See the table below for the tap position description:

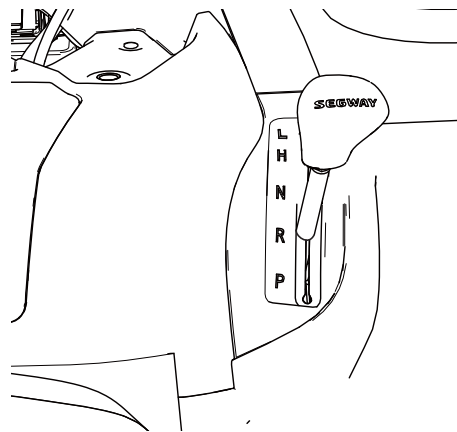

- L** Low speed
- H** High speed
- N** Neutral
- R** Reverse
- P** Parking

NOTICE

You need to step on the brake pedal when you change the gear.

If you change the gear when the engine is in idle speed or the vehicle is moving, it can cause transmission damage. Please place the transmission in parking gear and lock the parking brake when nobody drives the ATV.

Parking brake

The parking brake is on the left-hand handle.

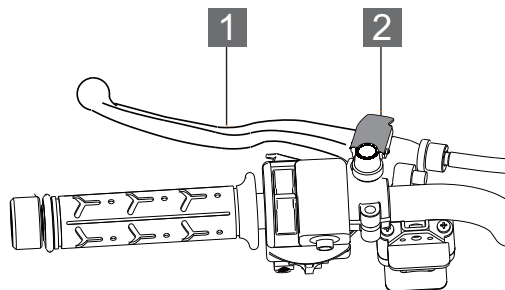

1 Parking brake lever

2 Parking brake lock

Using parking brake:

Place the shifter in "P" and squeeze the parking brake lever and hold;

Press the parking brake lock downward. After hearing the "click" sound, the brake lock gets stuck in the slot.

Release parking brake lever:

Squeeze the parking brake lever and the brake lock will automatically spring open. Then release the brake lever and the lock will be released.

Parking brake lever free clearance

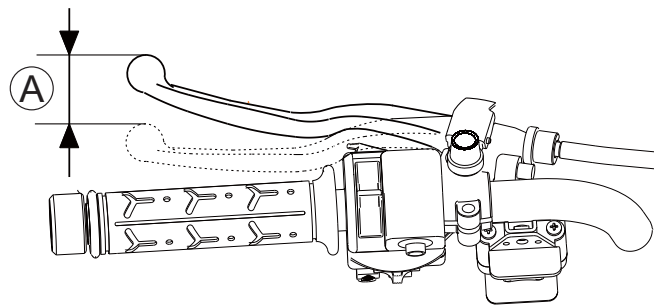

Parking Brake Checking

1. Hold the parking brake lever firmly, extrude and release, repeat several times, and the parking brake lever shall not be stuck.
2. Measure the distance the parking brake lever moves before the brake is maintained. Free stroke (measure tip of brake lever end) shall be: Ⓐ 1-13/16 in. (25-30mm)
3. Adjust to the specified scope if necessary.

Foot brake

The foot brake is the main brake system of the vehicle. The main brake is located on the right foot plate of the vehicle. When the vehicle needs to slow down or stop, step on the foot brake slowly. Emergency braking can cause the vehicle to skid or roll over, so do not use emergency braking when it is not necessary.

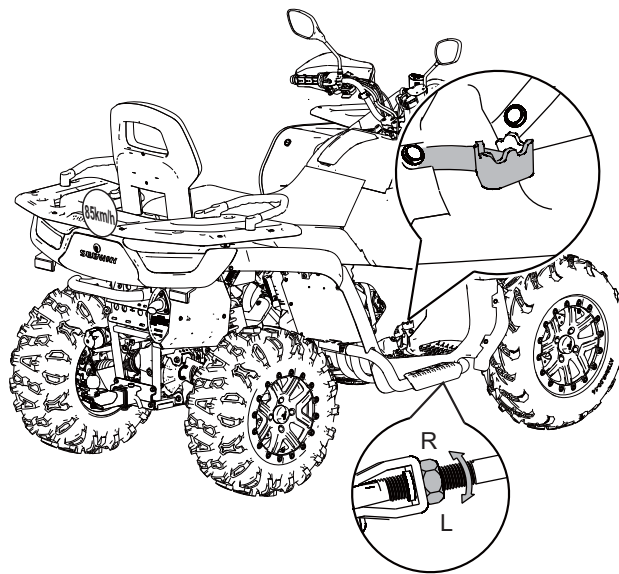
Foot brake lever adjustment

The foot brake lever adjusting nut is located at the bottom of the vehicle near the foot brake lever. The stroke height of the foot brake lever can be adjusted by twisting the foot brake lever nut.

- ◆ Turn nut in R direction and foot brake lever down.
- ◆ Turn nut in L direction, foot brake lever up.

Auxiliary brake

Auxiliary braking system refers to the backup device used as the main braking system. If the main brake system fails, use the auxiliary foot brake.

The auxiliary brakes are located on your right handle. use the auxiliary brakes to brake the front wheels of the vehicle. If the rear wheels slide while using the auxiliary brakes, the brake lever pressure is reduced to prevent the rear wheels from slipping while braking.

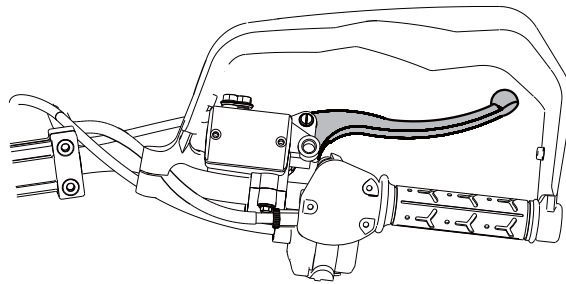

⚠ WARNING

Use the auxiliary brake carefully when going downhill. The use of the auxiliary brake can cause the vehicle to tip over backwards, resulting in serious injury or death.

Fuel tank cap

⚠ WARNING

Always fill the fuel type specified by the vehicle; Do not smoke when filling the vehicle with fuel or it may ignite the fuel and cause a fire disaster.

Do not touch other persons or objects with static electricity, which may cause static electricity to build up and ignite the fuel. Do not let the fuel spill while filling;

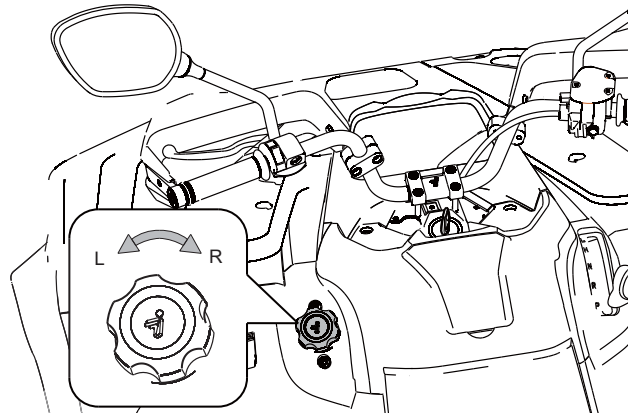

1. Unscrew the oil cap in the direction of "L";
2. Refueling the vehicle (don't overfill it);
3. Tighten the oil tank cap in the direction of "R" and close the oil tank cap

Storage box

The vehicle is equipped with three lockers.

1 Front storage box

Under the middle of the front handle of the vehicle, lift the glove compartment cover upward. The glove compartment is below.

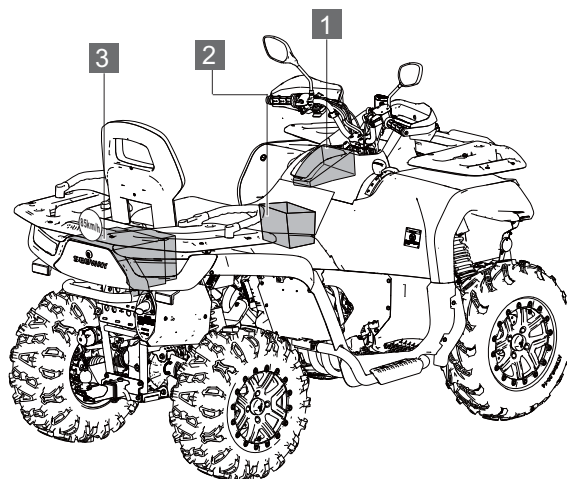

2 Intermediate storage box

Under the cushion, the cushion removal operation is shown in page 108.

3 Rear storage box

Located in the rear of the vehicle, this locker shall be ignition key switch or closed.

INSTRUMENT PARTS

The instrument provides the operator with the vehicle running parameter information, and the driver should understand the meaning of various indicators, warning lights and display content information on the instrument table, so as to timely understand the vehicle status.

NOTICE





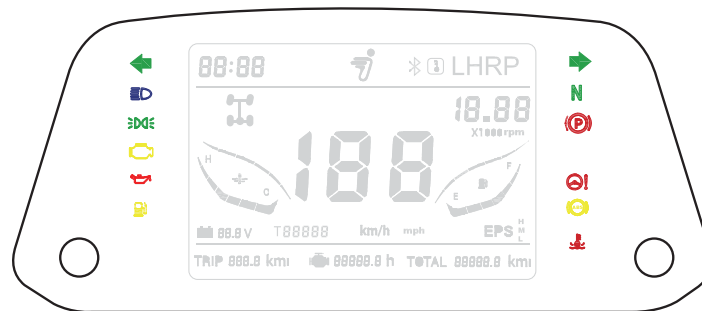

The combination meter may be damaged by using a high pressure cleaner. Do not clean the instrument with alcohol or corrosive detergent. Corrosive liquid will corrode the surface of the instrument and cause damage to the instrument.





Instrument indicator light/warning light

Indicator lights and warning lights on the instrument indicate the status of the vehicle's systems. The figure below shows all the lights and warning lights to illustrate.



Indicator light/warning indication

Item	Legend	Functional specifications
1 Turn Left		This light is lit when the left turn signal is turned on
2 High Beam		This lamp illuminates when the headlamp switch is set to high beam.
3 Position indicator		The front light, tail light, license plate light and instrument panel light are on
4 Check Engine		This indicator appears if an EFI-related fault occurs. Do not operate the vehicle if this warning appears. Serious engine damage could result.
5 Oil Pressure Warning		This light is on when oil pressure is too low.
6 Fuel level		The lamp lights up when the fuel level is too low
7 Coolant temperature warning lamp		Indicator light showing excessive temperature of engine coolant. When it lights up and alarms, the engine should be stopped immediately and shut down. After cooling down to normal temperature, the engine should continue to run

8 Turn right		This light is lit when the right turn signal is turned on
9 Neutral		This light is on when the gear shifter is in neutral (green)
10 Parking		This light is on after parking brake is applied
11 "ABS" warning light		Indicates a failure in the following system: : <ul style="list-style-type: none">• ABS ;• Brake assist system (optional equipment, if equipped)
12 Electric steering warning light		Indicates a failure in EPS system (optional equipment, if equipped)

Instrument information display area

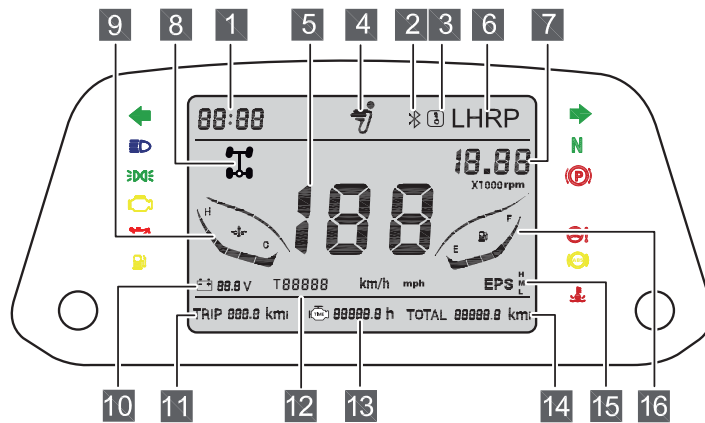

No	Graphic Meaning	Functional specifications
1	Time	Display current time
2	Bluetooth	The icon will light on when the APP Bluetooth power is used
3	Remote access to electricity	When power the ATV the APP in the mobile phone, and the light will be on
4	Logo	This sign lights up after power on
5	Speed	Display the actual vehicle speed The speedometer shows a speed of MPH (mile) or km/h (km/h)

6	Gear display	Display the correctly gear L -Low speed H -High speed R -Reverse P -Parking
7	Engine speed	Display actual engine speed
8	Four-wheel drive full differential lock	See page38-39
9	Coolant temperature indicator	Displays current coolant temperature H -High temperature C -Low temperature
10	Accumulator voltage	Displays the current voltage of the vehicle battery
11	Subtotal mileage	Single trip mileage
12	Fault code display	In case of partial failure of the vehicle, the fault code is displayed in this area. See page 57 for detailed description of the fault code.

13	Engine running time	Display engine running time
14	Total mileage	Displays the total mileage accumulated by the vehicle
15	EPS On	<p>EPS mode was set in the APP and the preferred mode of the rider was selected:</p> <p>M -Normal mode, power normal</p> <p>H -Comfort mode, power light</p> <p>L -Motion mode, booster weight</p>
16	Fuel meter	<p>Displays the current amount of fuel</p> <p>F -High fuel volume</p> <p>E -Fuel volume low</p>

Diagnostic displays code definitions

This area displays the code information of electrical components, circuits issues of the vehicle in case of failure or abnormality, please contact your dealer for any abnormalities or problems with this type of vehicle.

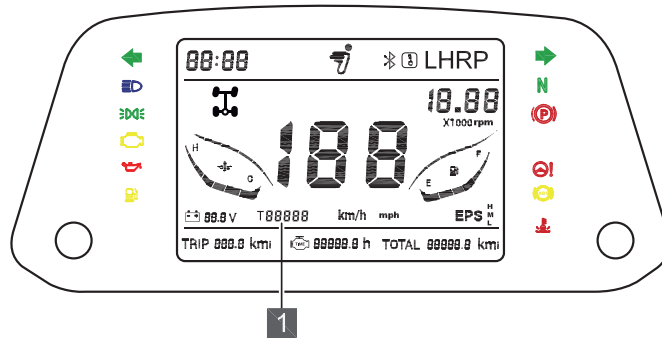

1 Fault code display area

System	Failure Code	Failure Description
ECU	P0123	Throttle position sensor High Voltage
	P0122	Throttle position sensor Low Voltage
	P0108	Manifold Absolute Pressure/ Barometric Pressure Circuit High
	P0107	Manifold Absolute Pressure/ Barometric Pressure Circuit Low

ECU	P0112	Intake Air Temperature Sensor 1 Circuit High
	P0113	Intake Air Temperature Sensor 1 Circuit Low
	P0117	Engine Coolant Temperature Sensor 1 Circuit High
	P0118	Engine Coolant Temperature Sensor 1 Circuit Low
	P0563	System Voltage High
	P0562	System Voltage Low
	P0560	System Voltage Not plausible
	P0132	O2 Sensor Circuit High Voltage Bank 1 Sensor 1
	P0131	O2 Sensor Circuit Low Voltage Bank 1 Sensor 1
	P0134	O2 Sensor Circuit Bank 1 Sensor 1
	P0130	O2 Sensor Circuit No Activity Detected Bank 1 Sensor 1
	P0032	O2 Sensor Heater Control Circuit High Bank 1 Sensor 1
	P0031	O2 Sensor Heater Control Circuit Low Bank 1 Sensor 1
	P0030	O2 Sensor Heater Control Circuit Bank 1 Sensor 1
	P0262	Cylinder 1 Injector Circuit High
P0261	Cylinder 1 Injector Circuit Low	

ECU	P0201	Injector Circuit/Open – Cylinder 1
	P0629	Fuel Pump “A” Control Circuit High
	P0628	Fuel Pump “A” Control Circuit Low
	P0627	Fuel Pump “A” Control Circuit /Open
	P0650	MIL Control Circuit Low
	P0650	MIL Control Circuit Open
	P0650	MIL Control Circuit Not plausible
	P0692	Fan 1 Control Circuit High
	P0691	Fan 1 Control Circuit Low
	P0480	Fan 1 Control Circuit
	P0322	Ign./Distributor Eng.Speed Inp.Circ. No Signal
	P0459	Evaporative Emission System Purge Control Valve Circuit High
	P0458	Evaporative Emission System Purge Control Valve Circuit Low
	P0444	Evaporative Emission System Purge Control Valve Circuit Open
	P1116	Engine Coolant Temp High
P0501	Vehicle Speed Sensor “A” Range/Performance	

EPS	E0001	No midpoint of torque is written
	E0002	No end point of rotor angle is written
	E0003	Memory read write failure
	E0004	The main torque sensor is disconnected
	E0005	Abnormal output of main torque sensor
	E0006	The secondary torque sensor is disconnected
	E0007	Abnormal output of secondary torque sensor
	E0008	The difference between main and secondary torques is too large
	E0009	The difference between the main torque before and after amplification is too large
	E0010	Electrical machinery unassisted
	E0011	Over electric current
	E0012	Abnormal busbar electric current
	E0013	CAN communication abnormal (Output abnormally)
	E0014	Rotor Angle jump
	E0015	The rotor Angle sensor is disconnected
	E0016	Power module failure
	E0017	Abnormal A phase electric current

EPS	E0018	Abnormal C phase electric current
	E0019	Steering wheel Angle small gear abnormal
	E0020	Steering wheel Angle middle gear abnormal
	E0021	Steering wheel Angle jumps
	E0022	Steering wheel Angle value exceeds limit
	E0023	The steering wheel Angle is not right
	E0024	Abnormal voltage at electrical machinery end
T-BOX	T0001	GPS module failure
	T0002	4G module failure
	T0003	Bluetooth module failure
	T0004	Sensor failure
	T0005	Power CAN failure
	T0006	Body CAN failure
ABS	A0001	Left front wheel speed error signal
	A0002	Right front wheel speed error signal
	A0003	Left rear wheel speed error signal
	A0004	Right rear wheel speed error signal
	A0005	Voltage of ABS module is too high

VEHICLE DEVICE**SEGWAY**

ABS	A0006	Voltage of ABS module is too low
	A0007	Vehicle speed single failure
	A0008	CAN single failure

Screen function setting

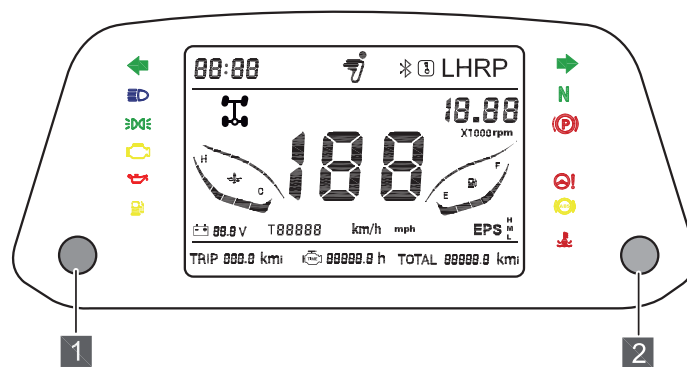

1 MODE

2 SELECT

MODE button

Press "MODE" button: Set the backlight level within 5 levels, from dark to bright.

Press "SELECT" button: Change the units (MPH or KPH);

Press and hold "SELECT" key: Clear the single trip mileage;

Press and hold "MODE" and "SELECT" at the same time: Clock setting; the hour digit blinks at first, press "SELECT" to adjust the hour digit, then press "MODE" to adjust the minute digit, finally press "MODE" key to save and exit;

HANDLEBAR ADJUSTMENT

The handlebars can be adjusted to suit the rider's angle.

⚠ WARNING

Improper adjustment of the handles or improper torque of tightening bolts can result in limited or loose of handler steering, loss of control can result in severe injury or death. Always follow the adjustment procedure, or check out the services at your dealer.

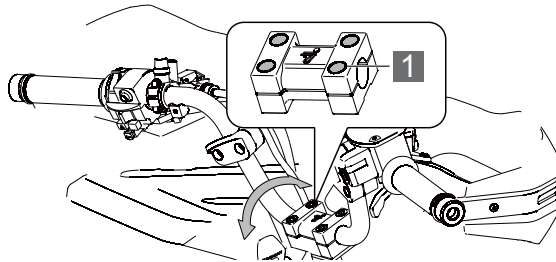

1 M8×48 (4 PC)

1. Loosen the four handlebar bolts.
2. Adjust the position of the handlebar according to the rider needs.
3. Tighten the two front bolts, and then tighten the two rear bolts. Leave a gap of 1/8 (3 mm) at the back of the clamp block.
4. Tighten the fastening bolts.

OPERATION

BASIC DRIVING GUIDE.....	67
Trail etiquette	67
Know your riding area/tread lightly.....	68
Vehicle Run-in-period.....	68
Brake system run-in.....	68
Clutch/belt.....	69
New operator driving procedures	69
Starting the vehicle.....	70
Park the Vehicle.....	70
Turning the vehicle	70
Driving in reverse.....	71
Turning around on a hill (k-turn)	72
Driving on slippery surfaces.....	73
Driving through water.....	74
Driving over obstacles.....	75
Driving uphill.....	76
Driving downhill.....	78
Driving on a sidehill	79



OPERATION

Parking on an incline80

Braking81

Parking the vehicle81

Break-in guidelines.....82

PRE-RIDE INSPECTION.....83

Inspection Items.....83

LOAD LIMITS & GUIDELINES.....85

Maximum loading capacity.....87

Loading Guidelines.....88

Trailer.....89

WINCH OPERATION.....91

This section provides basic operating instructions, including how to start and stop the vehicle, driving skills and precautions when driving on different roadways.

Even if you've ridden other ATVs, you must take time to familiarize yourself with how the vehicle operates. Practice in flat and wide areas until you are familiar with this all-terrain vehicle.

⚠ WARNING

Failure to inspect and verify that the vehicle is in safe operating condition before operating increases the risk of an accident. Always perform the Pre-Ride Inspection outlined in the Operation chapter before each use of your vehicle to make sure it's in safe operating condition. Always follow the inspection and maintenance procedures and schedules described in this owner's manual. See the Periodic Maintenance section of the Maintenance chapter.

BASIC DRIVING GUIDE

Trail etiquette

Always practice good etiquette when riding. Allow a safe distance between your vehicle and other vehicles operating in the same area. Communicate to oncoming operators by signaling the number of vehicles in your group. When stopping, move your vehicle to the edge of the trail as far as possible to allow others to pass safely.

Know your riding area/tread lightly

Familiarize yourself with all laws and regulations concerning the operation of this vehicle in your area. Respect the environment in which you ride your vehicle.

Find out where the designated riding areas are by contacting your dealer, a local riding club, or local officials. Help keep our trails open for recreational vehicle use.

Vehicle Run-in-period

Your vehicle 's run-in-period is the first 25 hours of operation or the riding mileage which used first two full tanks of gas. Careful handling of new engine and drive components will improve the performance and service life of these components. Follow these steps carefully.

Brake system run-in

In order to achieve the best braking performance, the brake must be not less than 200Km run-in when use.

Heavy or excessive braking when using the new braking system may damage the brake pad and disc.

Clutch/belt

Proper run-in of the clutch and driving belt will ensure longer service life and better performance. Run the run-in clutch and belt at low speeds for the recommended run-in time, only pulling light loads. Avoid violent acceleration and high-speed running during run-in. If the belt is broken, be sure to clean up the intake and outlet pipeline and any debris from the clutch and engine compartment during belt replacement.

New operator driving procedures

1. Wear protective riding gear. See the Safe Riding Gear section.
2. Perform the pre-ride inspection.
3. Place the transmission in PARK.
4. Mount the vehicle from the left side.
5. Sit upright with both feet on the footrests and both hands on the handlebars.
6. Start the engine and allow it to warm up.
7. Drive slowly. Practice maneuvering and using the throttle and brakes on level surfaces.

Starting the vehicle

1. Step forcefully on the foot brake.
2. Turn the ignition switch key to the " ON " position (P. 31).
3. Press the engine start button (green) to start the engine; (P. 32)
4. The vehicle is started.

Park the vehicle

1. Step on the foot brake and set the shifter to the "P" position;
2. Press the engine stop button (red) to stop the engine; (P. 32)
3. Turn the key to the " OFF " position (P. 31) and the key can be taken out of the switch.
4. Lock the handle parking brake lever; (P. 42)

Turning the vehicle

Both rear wheels drive equally at all times. This means that the outside wheel must travel a greater distance than the inside wheel when turning.

1. Slow down.
2. Steer in the direction of the turn.
3. Keep both feet on the footrests.
4. Lean your upper body to the inside of the turn while supporting your weight on the outer footrest. This

technique alters the balance of traction between the rear wheels, allowing the turn to be made smoothly. The same leaning technique should be used for turning in reverse.

5. Practice making turns at slow speeds before attempting to turn at faster speeds.

⚠ WARNING

Turning improperly can result in vehicle overturn.

Never turn abruptly or at sharp angles. Never turn at high speeds. Never turn quickly when carrying cargo.

Driving in reverse

If you need to ride in reverse, make sure the area behind you is clear and only operate the ATV at low speed.

Do not use the override switch unless additional wheel speed is required for vehicle movement. Use the override with caution as rearward vehicle speed is greatly increased. Do not operate at wide open throttle. Operate the throttle just enough to maintain a desired speed.

To reverse, follow the following procedure:

1. Always check for obstacles or people behind the vehicle, be sure there are no obstacles or people in the way.
2. Press the brake to change the shifter to "R";

Turning around on a hill (k-turn)

If the vehicle stalls while climbing a hill, never back it down the hill! Use the K- turn to turn around.

1. Stop and lock the parking brake while keeping body weight uphill.
2. Always move the 4X4 switch to 4WD (active descent control, The 4WD system allows engine braking to all four wheels when the vehicle descends a hill or incline. Always move the 4X4 switch to 4WD 4X4 before ascending or descending a hill.) 4X4 before ascending or descending a hill. See the Switch Location section for details.
3. Leave the transmission in "P" and shut off the engine.
4. Dismount on the uphill side of the vehicle, or on the left if the vehicle is pointing straight uphill. Staying uphill of the vehicle, turn the handlebars full left.
5. While holding the brake lever, release the parking brake lock and slowly allow the vehicle to roll around to your right until it's pointing across the hill or slightly downward.
6. Lock the parking brake. Remount the vehicle from the uphill side, keeping body weight uphill. Start the engine with the transmission still in "P".
7. Keep the transmission in "P" and start the engine.
8. Release the parking brake and proceed slowly, controlling

speed with the brake lever, until the vehicle is on more level ground.

Driving on slippery surfaces

Whenever riding on slippery surfaces such as wet trails or loose gravel, or during freezing weather, follow these precautions:

1. Do not operate on excessively rough, slippery or loose terrain.
2. Slow down when entering slippery areas.
3. Engage 4X4 before wheels begin to lose traction.

NOTICE

Severe damage to drive train may occur if the 4X4 is engaged while the wheels are spinning. Allow the rear wheels to stop spinning before engaging 4X4, or engage 4X4 before wheels begin to lose traction.

4. Maintain a high level of alertness, reading the trail and avoiding quick, sharp turns, which can cause skids.
5. Never apply the brakes during a skid. Correct a skid by turning the handlebars in the direction

Driving through water

Your ATV can operate through water with a maximum recommended depth equal to the bottom of the footrests. Follow these procedures when operating through water:



⚠ CAUTION

Major engine damage can result if the vehicle is not thoroughly inspected after operation in water. Perform the services outlined in the Periodic Maintenance Chart. The following areas need special attention: engine oil, transmission oil, demand drive fluid and all grease fittings. If the vehicle tips or overturns in water, or if the engine stops during or after operating in water, service is required before starting the engine. Your dealer can provide this service. If it's impossible to bring the vehicle in before starting the engine, perform the service outlined in the Vehicle Immersion section of this manual, and take the vehicle in for service at the first opportunity.

1. Determine water depths and current before entering water.
2. Choose a crossing where both banks have gradual inclines.
3. Avoid operating through deep or fast-flowing water.
4. After leaving water, test the brakes. Apply them lightly several times while driving slowly. The friction will help dry out the pads. If it's unavoidable to enter water deeper than the footrest level:
 - ◆ Proceed slowly. Avoid rocks and obstacles.
 - ◆ Balance your weight carefully. Avoid sudden movements.
 - ◆ Maintain a steady rate of speed. Do not make sudden turns or stops. Do not make sudden throttle changes.

Driving over obstacles



Follow these precautions when operating over obstacles:

1. Before operating in a new area, check for obstacles.
2. Watch out for bumps, potholes and other obstacles in the terrain.
3. When you approach any obstacle, reduce your speed and be prepared to stop.
4. Never try to ride over large obstacles, such as large rocks or fallen logs.
5. Always have a passenger dismount before operating over an obstacle that could cause a fall from the vehicle or vehicle tip over.

Driving uphill

Braking and handling are greatly affected when operating in hilly terrain. Improper procedure could cause loss of control or rollover. Whenever traveling uphill, follow these precautions:

1. Always move the 4X4 switch to 4WD 4X4 (if equipped) before ascending or descending a hill. Never operate in TURF mode while operating on a hill or other irregular terrain.
2. Drive straight uphill.
3. Avoid steep hills.

Maximum incline is:

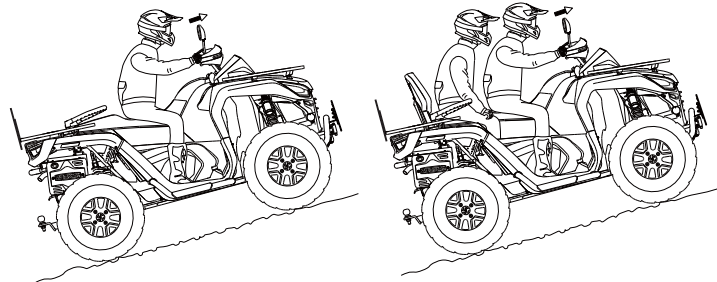

No passenger: 25°

With passenger: 15°

4. Always check the terrain carefully before ascending any hill.
5. Never climb hills with excessively slippery or loose surfaces.
6. Keep both feet on the footrests.
7. Shift body weight uphill. A passenger should also shift body weight uphill.
8. Proceed at a steady rate of speed and throttle opening. Opening the throttle suddenly could cause the ATV to flip over backwards.

Driving downhill

When driving downhill, follow these precautions:

1. Always move the 4X4 switch to 4WD 4X4 (if equipped) before ascending or descending a hill. Never operate in TURF mode while operating on a hill or other irregular terrain.
2. Avoid steep hills.

Maximum incline is:

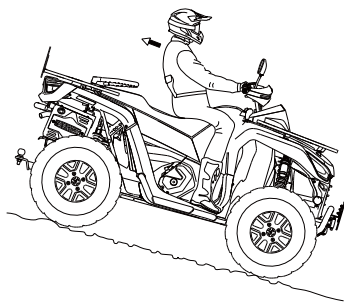

No passenger: 25°

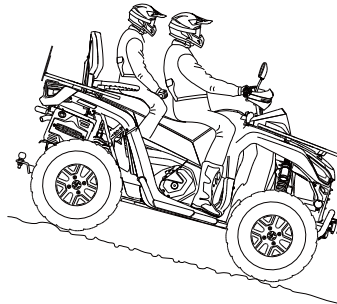

With passenger: 15°

3. Always check the terrain carefully before descending a hill.
4. Always descend a hill with the transmission in forward gear. Do not descend a hill with the transmission in neutral.
5. Slow down. Never travel down a hill at high speed.

6. Drive straight downhill. Avoid traveling down a hill at an angle, which would cause the vehicle to lean sharply to one side.
7. Shift body weight uphill. A passenger should also shift body weight uphill.
8. Apply the brakes slightly to aid in slowing. Applying the brakes too firmly may cause the rear wheels to lock, which could result in loss of control.

Driving on a sidehill



Driving on a sidehill is not recommended. Improper procedure could cause loss of control or overturn. Avoid crossing the side of any hill unless absolutely necessary.

If crossing a sidehill is unavoidable, follow these precautions:

1. Slow down.
2. Avoid crossing the side of a steep hill.
3. Lean into the hill, transferring your upper body weight toward the hill while keeping your feet on the footrests.
4. If the vehicle begins to tip, quickly turn the front wheel downhill, if possible, or dismount on the uphill side immediately!

Parking on an incline

Avoid parking on an incline if possible. If it's unavoidable, follow these precautions:

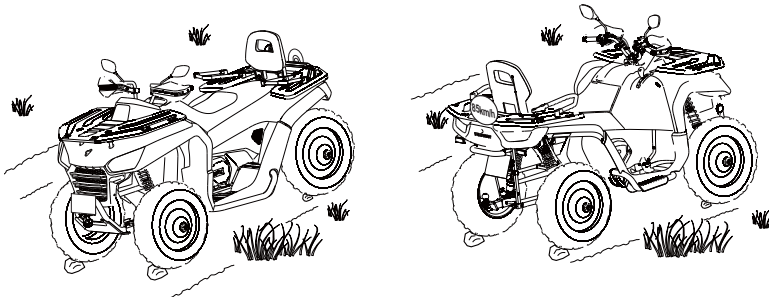

1. Stop the engine.
2. Place the transmission in PARK.
3. Lock the parking brake.
4. Always block the rear wheels on the downhill side.

Braking

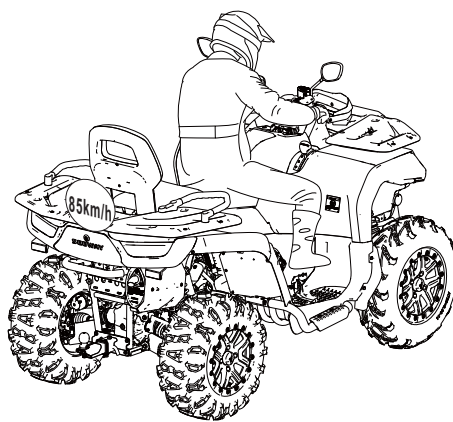

1. Release the throttle pedal completely. (When the throttle pedal is released completely and engine speed slows to near idle, the vehicle has no engine braking.)
2. Press on the brake pedal evenly and firmly. Practice starting and stopping (using the brakes) until you're familiar with the controls.

Parking the vehicle

1. Stop the vehicle on a level surface. When parking inside a garage or other structure, be sure that the structure is well ventilated and that the vehicle is not close to any source of flame or sparks, including any appliance with

- pilot lights.
2. Place the transmission in PARK.
 3. Turn the engine off.
 4. Engage the parking brake (if equipped).
 5. Slowly release the brake pedal and make sure the transmission is in PARK before exiting the vehicle.
 6. Remove the ignition key to prevent unauthorized use.

Break-in Guidelines

The engine needs 10 working hours or a 300km run-in period.

During run-in:

- ◆ Avoid full throttle operation.
- ◆ Avoid pressing the accelerator pedal for more than 3/4 stroke.
- ◆ Avoid continuous acceleration.

The brake needs a 200km run-in period.

New brakes will not operate at their maximum efficiency until the run-in period is over. Brake performance may be compromised, so be careful.

NOTICE

During this period, avoid full-throttle stares, rapid acceleration, and constant rpm operation.

PRE-RIDE INSPECTION

Perform a pre-ride inspection before each ride to detect any potential problem that could occur during operation. The pre-ride inspection can help you monitor component wear and deterioration before they become a problem.

Correct any problem that you discover to reduce the risk of a breakdown or crash.

Inspection Items

Project	Explanation	Page
Brake system / Lever stroke	Ensure correct operation	P44
Brake liquid	Ensure proper level	P126~ P129
Auxiliary brake	Ensure correct operation	P46
Front suspension	Check, lubricate if necessary	P139
Rear suspension	Check, lubricate if necessary	P139
Tires	Check status and air pressure	P131

Wheel/Fasteners	Check, ensure fasteners airtightness	P133
Fuel oil	Ensure proper level	P22
Cooling liquid level	Ensure proper level	P125
Indicator light	Ensure display status	P51
Switch	Ensure operation	P30
Engine off switch	Ensure correct operation	P32
Headlamp	Check operation	P33
Brake light /taillight	Check operation	P33
Riding equipment	Wear approved helmets, care and protective clothing	P17~P18
Trailer (optional equipment)	Check cable and interchanger	P91

LOAD LIMITS & GUIDELINES

The front and rear shelves of your vehicle are capable of carrying goods, and the towing device behind the vehicle can also carry the load.

Any load carried by the vehicle will affect the vehicle's operation, stability and braking distance. Do not exceed the vehicle load limit, including driver, passenger, cargo, components weight, and traction rod weight. It is important to be aware that the cargo may slip or fall to cause an accident

⚠ WARNING

- ◆ Strictly follow the instructions outlined in the operator's manual of the mounted or trailed machinery or trailer, and not to operate the combination tractor-machine or tractor-trailer unless all instructions have been followed.
- ◆ Stay clear from the area between vehicle and trailer.
- ◆ Reduce speed and allow greater braking distance when carry goods.
- ◆ The lower the height of the goods on the shelf, the better. Too much cargo on the shelves can destabilize the vehicle's center of gravity and reduce driving stability.

⚠ WARNING

- ◆ Fix all goods before operation. Unstable cargo can create unstable driving conditions, which can cause the vehicle to lose control.
- ◆ Heavy loading causes braking and control problems. Take extra care when using the brakes of a loaded vehicle. Avoid terrain or conditions that may be receding downhill.
- ◆ Take extra care when carrying goods beyond the edge of the shelf. Stability and mobility may be adversely affected, causing the vehicle to tip over.
- ◆ Do not block the headlight beam when loading on the front shelf.
- ◆ Don't drive faster than recommended. Vehicles should not exceed 9 MPH (15 km/h) when towing a load on flat ground. Towing loads, turning, or climbing or descending over rough terrain must not exceed a speed of 5 MPH (8 km/h).

Maximum loading capacity

Don't over the maximum loading capacity.

Vehicle Model		SGW570F-A3	SGW570F-A6
Front Shelf		40KG	40KG
Rear Shelf		60KG	60KG
Maximum traction	Horizontal	300KG	350KG
	Vertical	100KG	100KG

Loading guidelines

When transporting cargos, please follow below instructions:

1. Do not exceed the weight specified in the warning label and this manual.
2. Never ride with a passenger on the front or rear cargo racks.
3. Always load the goods on the shelf as far forward as possible. Ensure that the goods loaded on the rack are firmly secured before driving. If the cargo is not secured, it will cause unintentional dumping.
4. Make sure all cargo is secured before riding.
5. Avoid riding on steep slopes when carrying cargo or pulling a trailer.
6. Use low-speed gear when hauling heavy cargo.
7. When handling cargo, operate the vehicle with caution.

Trailer

The towing device is a detachable part. It can be removed from the ATV if you are not using a trailer. If you need to tow a load, pls be remained that the towing weight does not include the towing device.

- ◆ The combination of the weight of the rear rack and the traction rack shall not exceed the capacity of the rear rack.
- ◆ The total load (weight on the operator, accessories, cargo and trailer) shall not exceed the maximum capacity of the vehicle.

Where a designated attachment point is provided on the towbar:

Either:

Pass the cable through the attachment point and clip it back on itself.

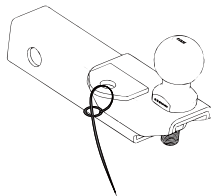

Or:

Attach the clip directly to the designated point, this alternative must be specially permitted by the trailer manufacturer since the clip may not be sufficiently strong for use in this way.

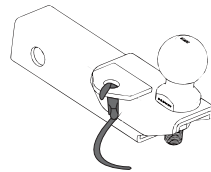

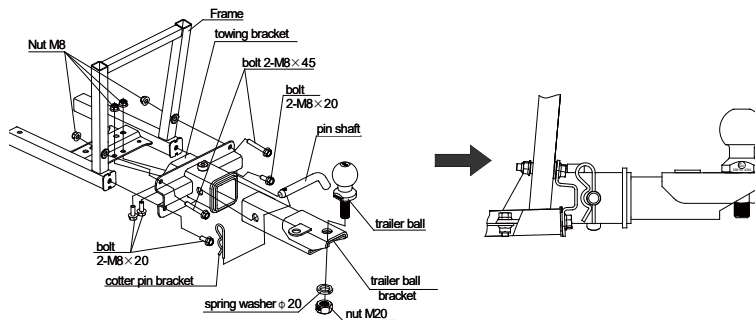

NOTICE

The speed must be less than 15 km/h during towing.
 Improper use of hooks or exceeding the maximum towing weight capacity may cause serious damage to your vehicle. In this case, your ATV will not be covered by service policy.
 Do not install trailers larger than 4 inches (10 cm). Never install vehicle accessories on the ATV. Always install accessories approved (or equivalent) designed for ATV use.

WINCH OPERATION

If your vehicle is equipped with a winch, please read this manual before installation and use to understand and be familiar with the relevant safety precautions and operating instructions.

WARNING

The user must read and understand the operating instructions and warnings of this operation manual. If the instructions or warnings are not followed, serious property damage or personal injury may occur.

- ◆ It is strictly prohibited for people under 16 years old to use this equipment.
- ◆ Before operation or during use, pay attention to the safety and environmental conditions within the operating range of the winch
- ◆ Do not overload. Ensure that all equipment used meets the maximum rope pull force rating. We recommend using an optional pulley block, double rope using a pulley block double rope to reduce the load on the winch, rope and battery. When double rope, the rated value of the pulley block should be two times the rope pull of the winch.
- ◆ Under heavy load, do not try to pull for a long time. Electric winches are only designed for Intermittent use, should not be used under constant load. Do not pull for

more than one minute or close to the rated load. If the winch motor feels very hot, stop winch and let it cool for a few minutes.

- ◆ The rope end cannot bear the full load, and the rope must rotate around the drum at least 5 laps.
- ◆ Avoid pulling the from extreme angles, as this will cause the rope to be rolled on One end of the barrel and damage the rope.
- ◆ Note that the rope-drawing capacity of the winch is the maximum rope-drawing capacity of the first layer, only the first the layer can only be pulled, do not operate the winch with overload capacity.
- ◆ Never hook the rope back to itself, otherwise the rope will be damaged. Use trunk protection protector.
- ◆ Before operation, make sure that the winch is firmly installed on the vehicle or bracket.
- ◆ Before moving heavy objects, check the wire rope to prevent kinks and uneven wire layers. The slack rope must be properly tightened under a weight of about 100Kg.
- ◆ When pulling the load, be sure to lay a blanket or protective layer on the wire rope near the hook end. This will prevent the possibility of breaking the wire rope and help prevent serious injuries and damage.

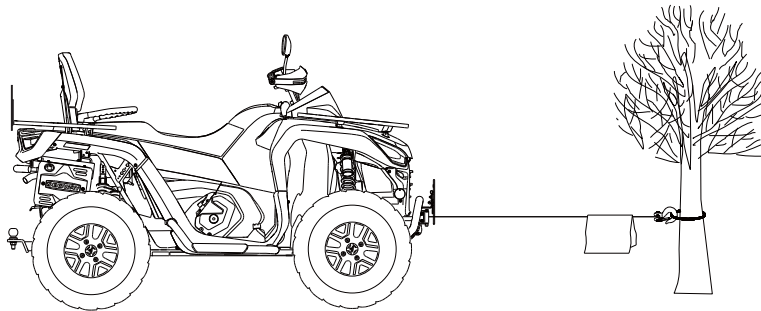

- ◆ Do not move the winch to assist in hauling heavy objects, It is easy to overload and cause damage to the wire rope.
- ◆ Pay attention to the dangerous area, stay away from the dangerous area during the operation, the dangerous area is The area of winch drum, fairlead, wire rope, pulley block, hook and motor.
- ◆ When the winch is under load, do not approach or cross the rope.
- ◆ When using the hoist to move the load, place the vehicle transmission in neutral and apply brake of the vehicle and plug all wheels with wedges. When the hoist is working, the vehicle engine should be operated to fully charge the battery. Never use the hoist with insufficient voltage.
- ◆ Never disconnect the power supply when there is a load on the winch.
- ◆ After the operation, please release the load immediately, and do not tighten the cable.

- ◆ Always stay away from ropes, hooks and winches.
- ◆ Check winches, ropes, hooks, and broken strands of worn wires regularly. When handling the steel wire rope, please wear thick leather gloves. Do not let the steel wire rope slip over your hands. Check the steel rope before use. The crushed, pinched, worn or kinked area has seriously reduced the carrying capacity. The damaged steel wire rope should be replaced. It must be re-wound under a load of about 100 pounds.
- ◆ The clutch should be disconnected first, and then the wire rope should be pulled by the hook of the protective lever. Do not pull the wire rope directly through the hook with your fingers.
- ◆ Maintain the specified tension so that the cable can be wound on the reel and re-rolled after the operation tight.
- ◆ Do not operate the winch under the influence of alcohol or drugs. In operation be vigilant during the process. If there is a problem, you should cut off the battery immediately and check it carefully.
- ◆ Wear goggles, insulating overalls, non-slip shoes, work caps, thick leather gloves, Place your hair tightly under the work cap and remove all jewelry.
- ◆ Do not mechanically process or melt any part of the winch.
- ◆ When the winch is in use, be sure to start the vehicle engine and set the gear position to "N" to make sure

battery is charging;

- ◆ When the winch is working, the current is large, so you must start the vehicle and step on the accelerator lightly to avoid damage to the battery;
- ◆ The winch rope and the vehicle should be in a straight line. Too big an angle will change the direction of the pulling force, thereby damaging the rope;
- ◆ If severe noise or vibration occurs during the use of the winch, it must be stopped immediately
- ◆ When the winch is not used, please remove the controller;

⚠ WARNING

When releasing or retrieving the winch rope, both ends of the rope must be left with sufficient

length to prevent the rope from being over-rolled in or out. When the rope is retrieving, please maintain a certain tension so that the wire can be retracted smoothly and can be wound tightly during retrieving.

⚠ WARNING

Always use the tow rope to pull the hook, Do not hold the hook with your hands. This is not only important when winding the wire rope, but also when removing the wire rope from the winch under power.

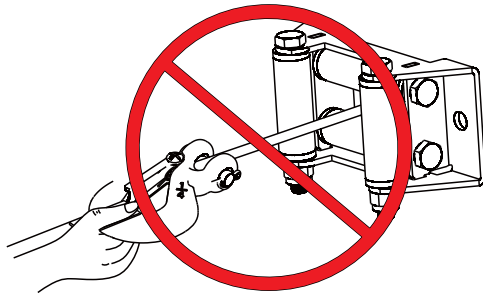

MAINTENANCE

REGULAR MAINTENANCE.....	101
PERIODIC MAINTENANCE TABLE.....	102
LUBRICATING OIL.....	107
SEAT CUSHION REMOVE.....	108
TANK COVER.....	109
REMOVE FRONT PANEL REPAIR	
COVER.....	110
REMOVE LOWER COVER OF INSTRUMENT.....	111
ENGINE OIL MAINTENANCE PROGRAM.....	112
Oil recommendation.....	113
Engine oil level check.....	114
Changing engine oil and filter.....	116
Drain the engine oil.....	117
Oil strainer clean.....	118
Oil filter change.....	119
Front/Rear gear box liquid.....	121
Front/Rear axle gear oil.....	122
COOLANT.....	124
Adding Coolant	124
BRAKE SYSTEM.....	126
Brake oil.....	127

MAINTENANCE

Front brake fluid.....	129
Brake component.....	130
TIRE.....	131
Tire pressure.....	131
Tread depth of tire.....	132
Replace the tires.....	133
Wheel component removal.....	133
Tire replacement	135
SHOCK ABSORBER ADJUSTMENT.....	136
Oil shock absorber.....	136
Adjustable shock absorber.....	137
SUSPENSION DRIVE LUBRICATION.....	139
DRIVETRAIN BOOTS.....	140
AIR FILTER.....	141
LAMP.....	143
Change the headlight.....	143
Replace taillight/rear turn light.....	146
High beam adjustment.....	147
SPARK PLUG.....	150
Spark plug inspection.....	151

MAINTENANCE

SPARK ARRESTER.....	153
BATTERY.....	155
Battery disassembly.....	156
Battery charging.....	157
Battery installation.....	159
FUSE.....	160
Fuse box.....	161
Fuse/relay distribution and rated amperage.....	162
Fuse box replacement.....	165
APPEARANCE CARE.....	166
Cleaning vehicles.....	167
Vehicle storage.....	167

⚠ WARNING

Failure to perform the maintenance instructions and precautions correctly will result in serious injury or death. Please follow the steps and precautions in this manual.

Proper maintenance is essential for safe operation. To help you properly maintain your vehicle, this part of this manual provides a maintenance plan.

The maintenance schedule in this plan assumes the vehicle is operated under normal conditions. If your vehicle often drives on rough roads or environments, your vehicle may require additional and more frequent maintenance. If you have some mechanical knowledge and basic tools, many maintenance items are simple and can be completed by yourself.

However, please note that certain maintenance tasks require special tools and professional skills. These tasks are best done by your dealer. Even if you have extensive self-maintenance experience, we still recommend that your dealers carry out repairs and maintenance. They will keep a maintenance record for your vehicle. This record will be useful when you need to apply for warranty service.

REGULAR MAINTENANCE

Any qualified repair shop can maintain, replace or repair the emission control device or system on your vehicle. Authorized dealers can perform any services that may be required for your vehicle. Parts are also recommended for emissions-related services, but equivalent parts can be used.

If the part provided by the after-sales component manufacturer reduces the effectiveness of vehicle emission control, this is a potential violation of the Clean Air Act. Violation of the law prohibits pollution discharge control.

The user is responsible for performing the regular maintenance specified in the user manual. Careful and regular maintenance will help keep the vehicle safe and reliable. Check, clean, lubricate, adjust and replace parts when necessary. When the inspection shows that the parts need to be replaced, new parts can be obtained from the dealer. Equivalent components that can be used for emissions-related services. If you are not familiar with security services and adjustment procedures, qualified dealers can perform these operations. The maintenance intervals in the chart below are based on average riding conditions. Frequently used vehicles must be checked and repaired more often.

PERIODIC MAINTENANCE TABLE

Careful periodic maintenance will help keep your vehicle in the safest, most reliable condition. Inspection, adjustment and lubrication of important components are explained in the periodic maintenance chart.

Inspect, clean, lubricate, adjust and replace parts as necessary. When inspection reveals the need for replacement parts, use genuine parts available from your authorized dealer. Service and adjustments are important for proper vehicle operation. If you're not familiar with safe service and adjustment procedures, have a qualified dealer perform these operations.

Maintenance intervals in the following chart are based upon average riding conditions. Vehicles subjected to severe use must be inspected and serviced more frequently.

Severe use is defined as:

- ◆ **Frequent immersion in mud, water, or sand**
- ◆ **Frequent or prolonged operation in dusty environments**
- ◆ **Short trip cold weather operation**
- ◆ **Racing or racing-style high RPM use**
- ◆ **Prolonged low speed, heavy load operation**
- ◆ **Extended idle**

MAINTENANCE CHART KEY

SYMBOL	DESCRIPTION
▶	Perform these procedures more often for vehicles subjected to severe use.
D	Have an authorized dealer or other qualified person perform these services.

⚠ WARNING

Improperly performing the procedures marked with a D could result in component failure and lead to serious injury or death. Have an authorized dealer or other qualified person perform these services.

MAINTENANCE

SEGWAY

Perform all services at whichever maintenance interval is reached first. Record maintenance and service in the Maintenance Log.

ITEM	MAINTENANCE INTERVAL (WHICHEVER COMES FIRST)			REMARKS
	HOURS	CALENDAR	MILES (KM)	
Steering		Pre-Ride		Visually inspect, test, or check components. Make adjustments and/or schedule repairs when required
Front suspension		Pre-Ride		
Rear suspension		Pre-Ride		
Tires/ Wheels/ fasteners		Pre-Ride		
Brake fluid level		Pre-Ride		
Brake system		Pre-Ride		
Accelerator		Pre-Ride		
Engine oil level		Pre-Ride		
▶ Air filter, pre-filter		Daily		Inspect; clean often; replace as needed
Coolant		Daily		Check level
Power steering unit (if equipped)		Daily		Inspect daily; clean often
Headlight/ taillight/ worklight		Daily		Check operation; apply dielectric grease if replacing lamps
▶ Air filter, main element		Weekly		Inspect; replace as needed

ITEM	MAINTENANCE INTERVAL (WHICHEVER COMES FIRST)			REMARKS
	HOURS	CALENDAR	MILES (KM)	
▶ D Brake pad wear	10 H	Monthly	100 (160)	Inspect periodically
Battery	20 H	Monthly	200 (320)	Check terminals; clean; test
Fuel System	20 H	Monthly		Inspect; cycle key to pressurize fuel pump; check lines and fittings for leaks and abrasion
▶ Engine oil change	25 H	1 M	200 (320)	Break-in oil and filter change
▶ Front gearcase oil	25 H	1 M	200 (320)	Break-in oil level check
▶ Rear gearcase oil	25 H	1 M	200 (320)	Break-in oil level check
▶ General lubrication	50 H	3 M	500 (800)	Lubricate all fittings, pivots, cables, etc.
Throttle Body Intake Duct	50 H	6 M		Inspect duct for proper sealing/air leaks
Drive belt	50 H	6 M	500 (800)	Inspect; adjust; replace as needed
Cooling system	50 H	6 M	1000(1600)	Inspect coolant strength seasonally; pressure test system yearly
▶ Engine oil change	100 H	6 M	1000(1600)	Change the oil and filter
▶ Oil lines and fasteners	100 H	6 M	1000(1600)	Inspect for leaks and loose fittings
▶ Front gearcase oil	100 H	12 M	1000(1600)	Change fluid;
▶ Rear gearcase oil	100 H	12 M	1000(1600)	Change fluid
D Fuel system/filter	100 H	12 M	1000(1600)	Cycle key to pressurize fuel pump; check for leaks at fill cap, fuel lines/rail and fuel pump; replace lines every two years

MAINTENANCE

SEGWAY

ITEM	MAINTENANCE INTERVAL (WHICHEVER COMES FIRST)			REMARKS
	HOURS	CALENDAR	MILES (KM)	
▶ Radiator (if applicable)	100 H	12 M	1000 (1600)	Inspect; clean external surfaces
▶ Cooling hoses (if applicable)	100 H	12 M	1000 (1600)	Inspect for leaks
▶ Engine mounts	100 H	12 M	1000 (1600)	Inspect
Exhaust muffler/ pipe / Joints	100 H	12 M	1000 (1600)	Inspect; clean; replace worn parts
D Spark plug	100 H	12 M	1000(1600)	Inspect; replace as needed
D Clutches (drive and driven)	100 H	12 M	1000 (1600)	Inspect; clean; replace worn parts
D Front wheel bearings	100 H	12 M	1000 (1600)	Inspect; replace as needed
D Brake fluid	200 H	24 M	2000(3200)	Change every two years
Spark arrester	300 H	36 M	3000(4800)	Clean out
▶ Coolant		60 M		Replace coolant
D Valve clearance	500 H		5000 (8000)	Inspect; adjust
Idle speed				Adjust as needed
D Toe adjustment				Inspect periodically; adjust when parts are replaced
Headlight aim				Adjust as needed

LUBRICATING OIL

Check and lubricate all components at the intervals listed in the periodic maintenance chart. Items not listed in the chart should be lubricated in the general lubrication interval. The rocker arm is lubricated at the factory and does not require additional lubrication. However, if these components are heavily used, the user may perform additional lubrication as required.

Project	Recommended model	Capacity	Inspection procedure
Engine oil	10W/40-SL	2.4L	Maintain level in safe range on dipstick
Front axle gear oil	SAE 80W/90	280mL	Drive each 2000km(1200MI) Kilometers.
Rear axle gear oil	SAE 75W/90 or SAE 80W/90	220mL (No differential) 260mL (With differential)	
Coolant			Maintain the level between the fill lines.
Brake fluid	DOT4		Maintain the level between the fill lines.
Suspension, balance bar grease		—	Grease nozzle (3 Pump max) per 500 mile.

SEAT CUSHION REMOVE

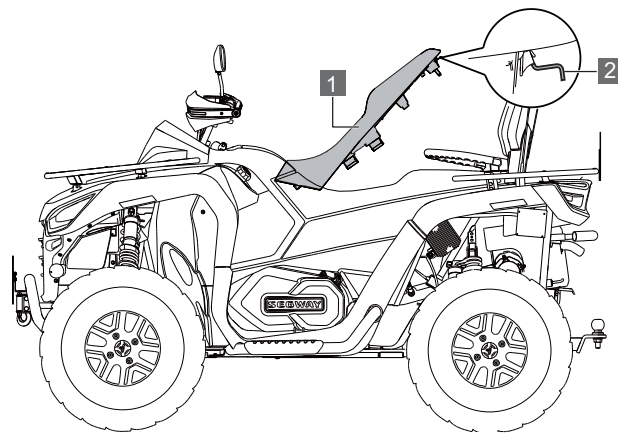

1 Cushions

2 seat hook

1. Hook the seat hook with your fingers and move upward;
2. Lift the seat cushion upward after it bounces off;
3. Take a seat cushion.

TANK COVER

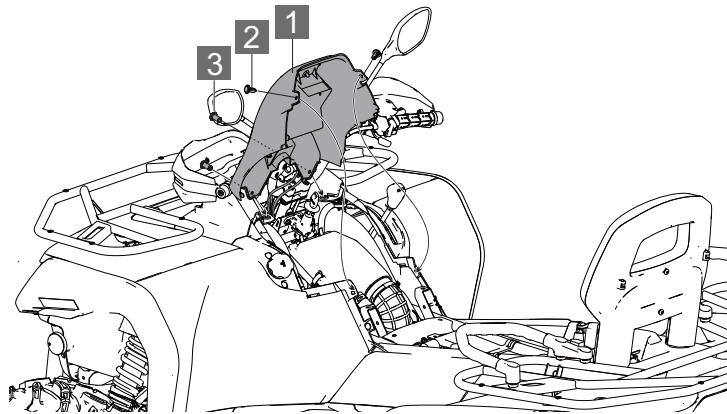

1 Tank cover

2 Expansion screws

3 Hexagon screw

1. First remove the seat (see page 108);
2. Remove the two expansion screws in front of the tank cover with tools;
3. Remove the two hexagon screws behind the tank cover;
4. Lift the tank shield upward;

NOTICE

There are two connecting wire harness at the bottom of the tank shield. If the tank shield needs to be completely removed, please pull out the connecting wire plug.

REMOVE FRONT PANEL REPAIR COVER

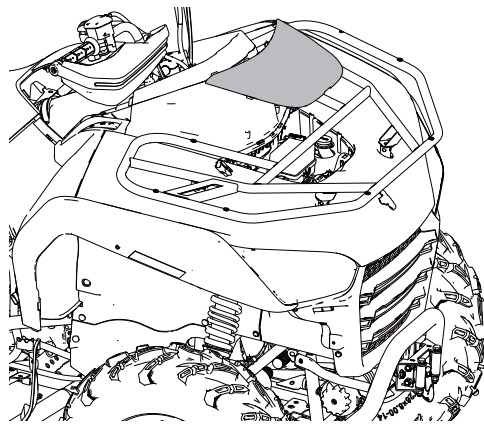

To remove the front repair cover, do as following:

The front panel maintenance cover is fast removable snap-type installation, and you only need to lift the front of the maintenance cover up by hand.

When lifting up the maintenance cover, do not force too much, in order to avoid the maintenance cover and the upper shelf support bar collision, damage the spray paint of the maintenance cover.

Coolant adding mouth and fuse box are located under the repair cover. Please refer to the repair cover folding and unloading procedure in this section to add cooling aid or replace the fuse.

REMOVE LOWER COVER OF INSTRUMENT

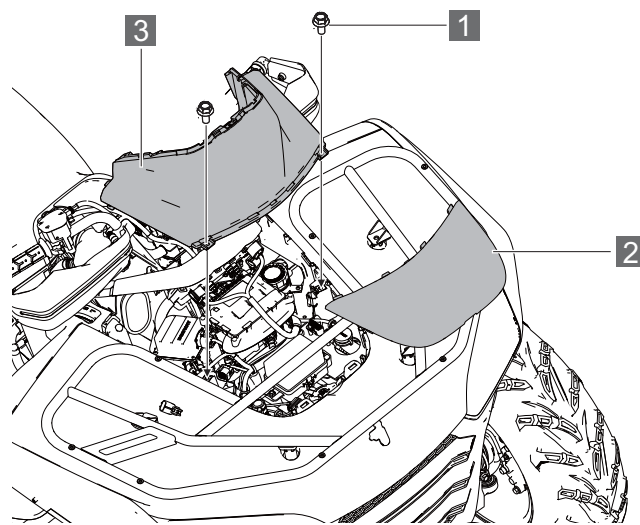

- 1 Bolts (2 pc)** **2 Remove front panel repair cover**
- 3 Remove lower cover of instrument**

To remove the lower cover:

1. Remove the front panel repair cover **2** (See Page 110);
2. Remove 2 fix screw under lower cover of instrument by tools **1** ;
3. Remove lower cover of instrument **3** 。

ENGINE OIL MAINTENANCE PROGRAM

Be sure to check and change the oil at the time required by the regular maintenance chart. Be sure to use recommended engine oil. The oil filter must be changed every time the oil is changed. Pay special attention to the oil level. An increase in the oil level during cold weather can indicate contaminants collected in the oil sump or crankcase. If the oil level starts to rise, change the oil immediately. Monitor the oil level, if it continues to rise, stop using it and determine the cause. Your dealer can assist.

⚠ WARNING

Vehicle operation with insufficient, degraded or contaminated engine oil will cause accelerated wear and tear, and may result in engine jams, accidents and injuries. Always perform the maintenance procedures listed in the periodic maintenance chart.

Oil recommendation

The oil filter must be changed every time the oil is changed.

It is recommended to use 10W/40-SL four-cycle oil or similar oil for this engine. Follow the manufacturer's recommendations for ambient temperature operation. Please refer to the lubricant guide section for fluid recommendations, capacity and blocking torque.

NOTICE

Mixing brands or using non-recommended oils may cause serious engine damage. Always use the recommended oil. Never replace or mix oil brands.

Engine oil level check

NOTICE

Running the engine with an improper oil level can cause serious engine damage.

1. Park the vehicle on a level ground. Wait at least 5 minutes to allow the oil to flow back to the bottom of the engine.
2. Put a piece of cotton cloth under the end of the oil dipstick, and then pull out the oil dipstick.
3. Wipe the oil dipstick clean.
4. Reinsert completely;
5. Put a piece of cotton cloth under the end of the oil dipstick, then pull out the oil dipstick and check the oil level.

Check the oil level as shown in the figure below: The oil level is between the Upper engraved line **1** and the Lower engraved line **2**. Below the lower scale means the oil is too low, and the upper scale means the oil is too full.

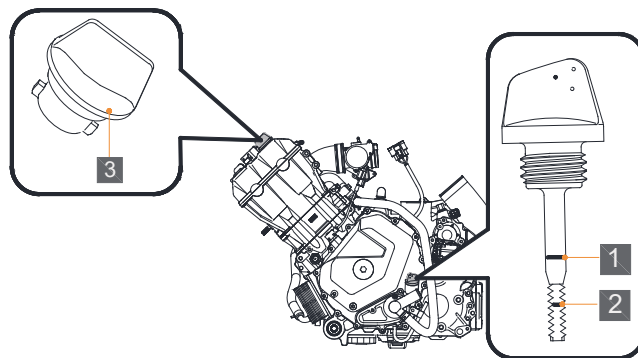

1 Upper engraved line

2 Lower engraved line

3 Oil filler cap

6. After cleaning the oil dipstick, fully insert it again.
7. If the oil level is near or below the lower level mark, remove the seat (see page108) .Remove the oil fill cap **3** from the front right crankcase cover and add the specified oil into the fill cap hole, up to the upper level mark on the dipstick.
8. Reinstall the oil fill cap and dipstick.
9. Install the tank cover assembly.
10. Install the seat.

Changing engine oil and filter

NOTICE

Whenever changing oil, it is recommended to change the oil filter.

WARNING

- ◆ The used engine oil contains potentially hazardous pollutants, which can cause skin diseases such as dermatitis and skin cancer, so care should be taken to avoid prolonged and repeated exposure to such oils. Wash the skin thoroughly with soap and water to remove the used engine oil.
- ◆ The used oil and filtration must be scrapped in a safe and compliant way with environmental regulations. Do not dispose of used oil and filters in domestic garbage, sewers or on the ground. For information on oil recycling or scrapping, please consult your Segway dealer.
- ◆ Do not put used engine oil in a place where children can reach.

Drain the engine oil

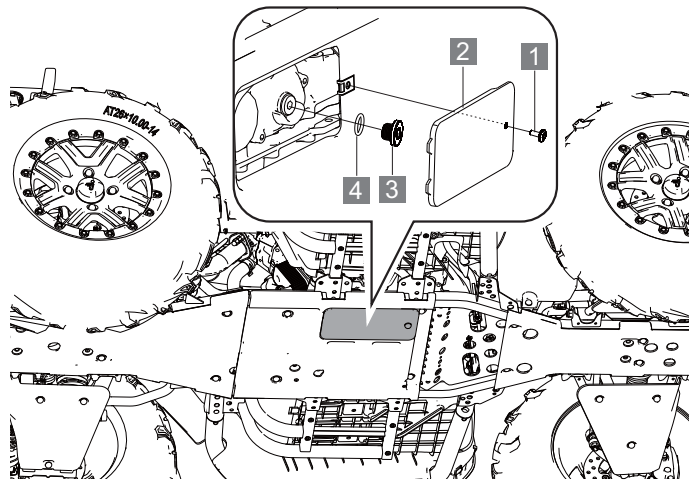

1 Screw

2 Filter inspection cover

3 Oil drain plug

4 O-ring

1. Put the vehicle on the flat level surface.
2. Start the engine, let it warm up at idle for 2 to 3 minutes.
3. Turn off the engine.
4. Remove the fixing screws of the filter inspection cover and open the filter inspection cover.
5. Remove the oil drain plug **3** and O-ring, until the waste engine oil drains out completely.

NOTICE

The hot oil may burn the skin, Do not let the oil contact skin.

- Put a new sealing washer onto the drain plug and reinstall the drain plug **3** .

Torque specifications :

Torque	Oil drain plug: (16~20)N.m
--------	-----------------------------------

Oil strainer clean

The oil filter of this engine is a two-stage filter. The oil filter screen filters the oil at the first stage. Clean the oil according to the time required. Do not use poor quality oil.

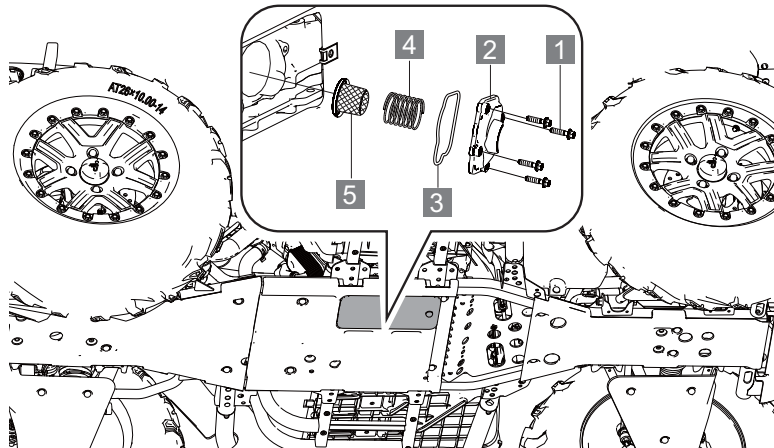

- | | |
|-----------------------|--------------------------|
| 1 Bolt M6*25*8 | 2 Strainer cover |
| 3 O-rings seal | 4 Strainer spring |
| 5 Oil strainer | |

The oil filter can be checked after the oil is discharged. If cleaning is needed, please take the following steps:

1. Remove 4 bolts with tools;
2. Remove the strainer cover, O-ring seal and strainer spring in turn;
3. Take out the oil filter for cleaning;
4. The installation step is opposite to the removal step

Oil filter change

This procedure requires mechanical skill and professional tools such as a torque wrench as well as a means for disposing of the drained fluid. If you do not have the skills or the tools, see your dealer.

Check the fluid recommendation table for capacities and plug torques. Always change the oil filter at the same time when changing the oil

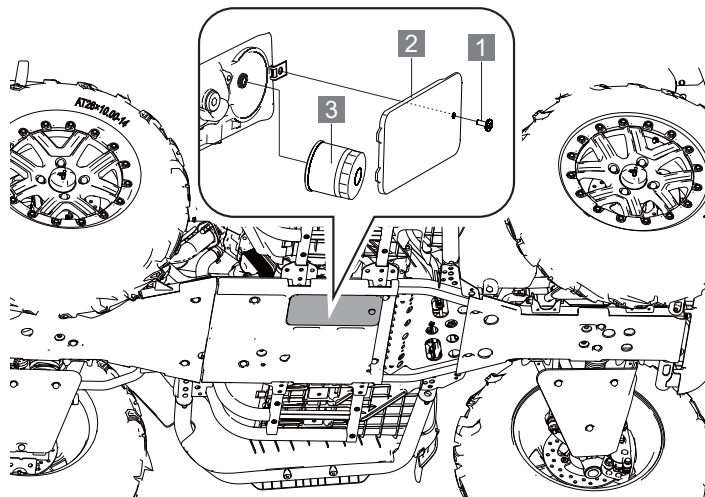

1 Screw 2 Oil filter inspection cover 3 Oil filter

1. Remove the fixing screws of the filter inspection cover and open the filter inspection cover. You can see the black cover. The oil filter is located here. Put the towel under the oil filter
2. Change a new O shape ring onto a new oil filter, inspect and make sure the O shape ring is in good condition.
3. Remove the oil filter to be replaced by the tool counterclockwise;

Rotate clockwise to install the new filter until the filter gasket touches the sealing surface. Tighten the can.

Front/Rear gear box liquid

Please check and replace the required driving fluid at intervals listed in the periodic maintenance chart.

NOTICE

If the front gearbox makes excessive noise during 4WD operation, please change the demand drive fluid. If the noise continues, please ask Segway Powersports dealers or other qualified service facilities for vehicle inspection and service.

Use recommended oil. The use of other liquids may cause improper operation of parts.

Front/Rear axle gear oil

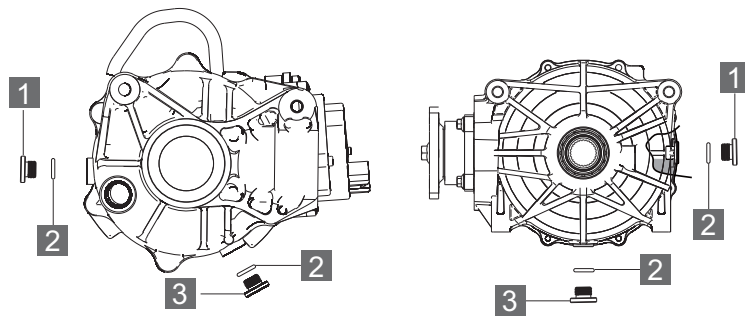

1 Filling plug

2 O-ring

3 Drain plug

1. Put the vehicle on the flat level surface
2. Place an oil drain pan under the drain plug **3** ;
3. Remove the drain plug **3** and O-ring **2** ;

Torque to specification:

Torque	Drain Plug: 16~20N.m
--------	----------------------

4. After the oil has completely drained, reinstall the drain plug **3** and a new O-ring **2** .

The oil discharged is harmful to the environment. Properly dispose of the oil properly;

5. Remove the Filling plug **1** and O-ring **2** , Add the recommended liquid as needed to make the liquid level reach the bottom of the filling hole thread.

6. Reinstall the O-ring and filling plug

Torque to specification:

Torque	Filling Plug:16~20N.m
--------	-----------------------

7. Check for the leak.

NOTICE

Dispose of used fluid properly.

COOLANT

The coolant circulates in the engine cooling system, taking away the excess heat generated during the engine operation and making the engine operate at normal operating temperature. Maintaining the coolant will allow the cooling system to work properly and prevent freezing, overheating, and corrosion. Therefore, the coolant should be frequently checked. The factory provides a 50/50 solution of antifreeze and water in this ATV. This coolant solution is recommended for most operating temperatures and provides good corrosion protection.

Adding Coolant

The recovery bottle is located on the left side of the vehicle.

1. Observe the liquid level in the bottle
2. If the liquid level is low, remove the cap and add coolant as needed. Maintain the coolant level between the minimum **2** and maximum **1** marks on the bottle (when the liquid is cool).
3. Remove the front panel maintenance cover in the middle area of the front upper part of the vehicle (see page 110);
4. Unscrew the lid, pour in new coolant. Pay attention to the position of the coolant when pouring in, and do not exceed the maximum liquid level
5. Tighten the lid of the cooling bottle

6. Reinstall the instrument cover and confirm whether the instrument cover is installed

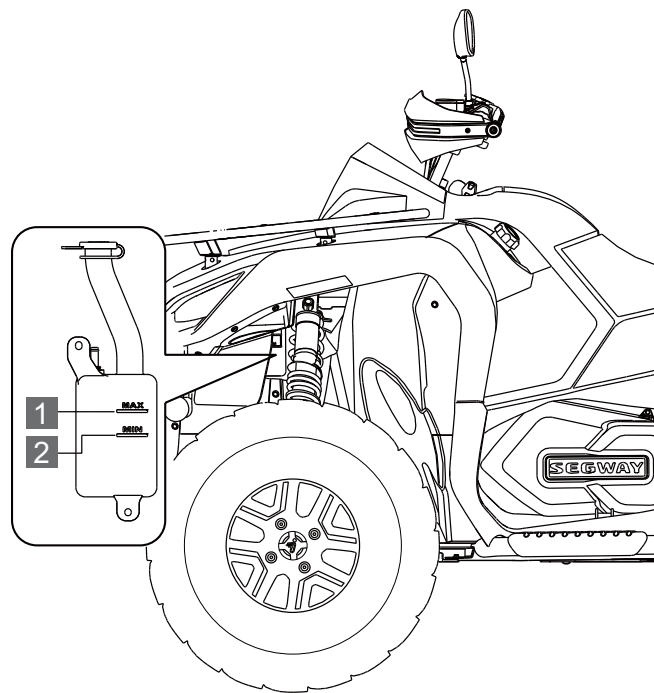

1 Maximum

2 Minimum

BRAKE SYSTEM

The front and rear brakes are hydraulic disc brakes that are activated by moving a single brake lever towards the handlebars. These brakes are self-regulating. As the brake disc wears away, the brake fluid level will drop, and the leakage in the system will cause the fluid level to drop.

WARNING

Brake fluid levels must be checked periodically: overfilling of the brake cylinder may cause brake resistance or brake locking, which may result in serious injury or death. Keep brake fluid at the recommended level and do not overfill. Must check brake disc brake disc wear condition regularly: if brake disc wear, should be replaced.

The following inspection is recommended to keep the braking system in good working condition. If the brake is in heavy use during normal operation, check it frequently.

1. Always keep the brake fluid at an appropriate level. Please refer to master cylinder/brake fluid section for details.
2. Check the braking system for liquid leakage.
3. Check whether the brake travels too long or feels soft.
4. Check whether the friction gasket is worn, damaged or

loose. When replacing the brake gasket, the brake pad must be replaced when the remaining limit thickness of the brake pad is not less than 1mm.

5. Check the safety and surface condition of the disc. Use the recommended brake cleaner or liqueur to clean any grease. Do not use spray lubricants or other petroleum-based products. If any damage (crack, excessive corrosion, warping) is found, please check the dealer's service before operation.

Brake oil

Use the recommended brake oil:

Brake Oil	DOT4
-----------	------

No adjustment is required for the hydraulic assisted braking system. Check the brake oil level of the auxiliary braking system frequently. If the level is shown to be low, perform the following operations. The brake oil cup is located below the front panel.

1. Remove the front shelf and the lower cover of the instrument. See Page110 and 111 for the removal method;
2. Observe the liquid level in the container:

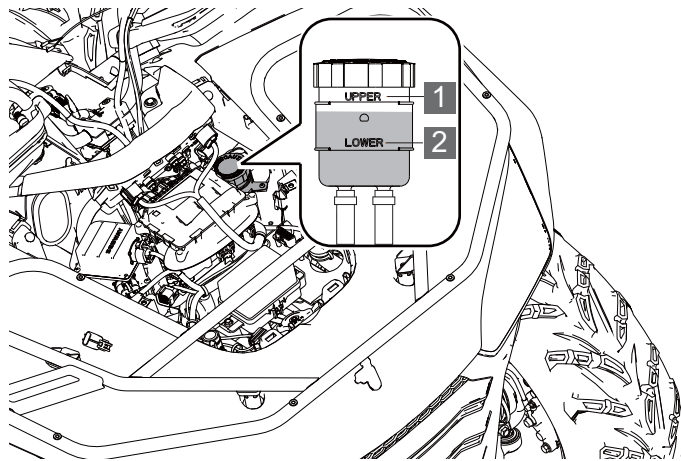
**1 UPPER****2 LOWER**

3. The brake fluid level is most suitable between the upper plane and the lower plane. If it is lower than the lower plane, please add the recommended brake fluid and observe the liquid level.
4. Check whether the brake pads are worn.

NOTICE

Brake fluid can damage plastic and painted surfaces and should be added with caution. If the brake fluid comes into contact with the skin or eyes, flush with plenty of water immediately. If you feel unwell, seek medical advice immediately.

Front brake fluid

Check whether the front brake fluid level is below the minimum liquid level mark on the right handlebar. When the liquid level is below the minimum liquid level, perform the following operation.

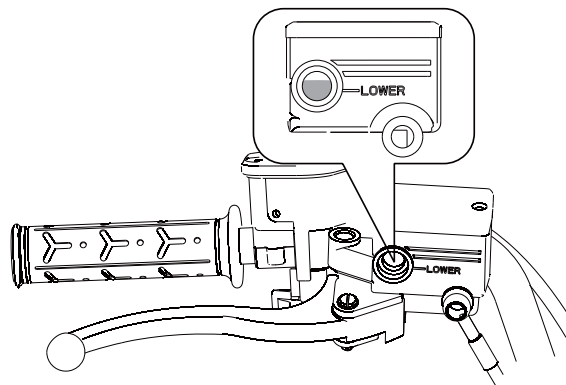

LOWER

1. Replenish brake fluid in time
2. Check whether the brake pads are worn

Brake component

Brake component consumption will depend on the severity of operating and operating conditions. Brake component consume faster in wet and muddy conditions. Periodically inspect brake component for consumption according to the maintenance periodic table. If the brake pad thickness is less than or equal to minimum thickness of 1.00 mm, the brake component must be replaced.

Brake components thickness	Standard thickness	5.0mm
	Minimum thickness	1.0mm

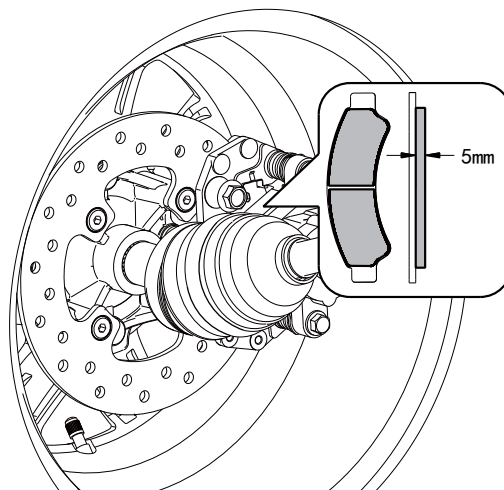

TIRE

Tire pressure

Driving a vehicle with incorrect tire pressure may result in the following consequences:

- ◆ Reduce fuel efficiency
- ◆ Reduced driving comfort and shortened tire life
- ◆ Safety reduction

When checking tire pressure, follow the following instructions:

Recommended	Front wheel	Rear wheel
tire pressure	7.0psi (48.3kPa)	7.0psi (48.3kPa)

- ◆ Inspection can only be carried out after the tire cools down.
- ◆ If the vehicle has been parked for at least 3 hours, or has not driven more than 1.5km. Rechecking at this time can get an accurate reading of the cold tire inflation pressure.
- ◆ Do use tire pressure gauges. Tire appearance can sometimes be misleading. In addition, even a few pounds less air in a tire can affect driving and handling

performance.

- ◆ Don't reduce the tire pressure after driving. Increased tire pressure is normal after driving.

Tread depth of tire

- ◆ Observe the tire shoulder to find the tire wear limit alarm mark "T.W.I.", follow the triangle sign to see the past, found that the tire tread has the corresponding convex, when the pattern block convex surface wear to the convex position, you should change the tire, otherwise due to insufficient strength, the tire will burst midway

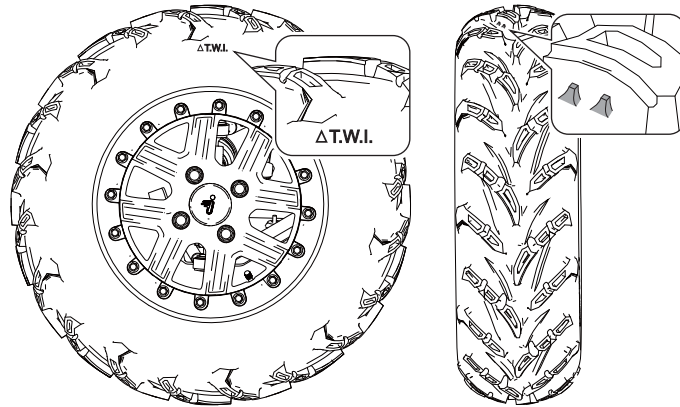

When to Change a tire A tire should be changed if:

- ◆ It is found that the tire is damaged, such as the cut, the

lamination, the deep crack of the curtain layer, and the bulge indicating the tire interior is damaged.

- ◆ Tires often have air leaks and cannot be normally repaired due to the size or position of incisions or other injuries. If you are not sure, consult your dealer.

Replace the tires

When the tire tread wear has reached the replacement mark or the tire is damaged due to external force impact, a new tire should be replaced.

Wheel component removal

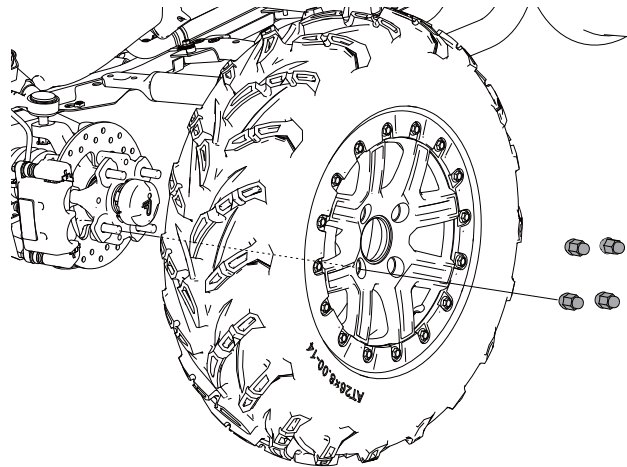

Torque to specification:

Torque	Mounting nuts:70~80N.m
--------	------------------------

1. Stop the engine.
2. Put the gear shifter in "P" position.
3. Lock parking brake.
4. Lift the side of the vehicle by placing a suitable bracket under the frame of the foot frame.
5. Loosen 4 hub mounting nuts with tools.
6. Remove the entire wheel.

⚠ CAUTION

The loose nut may cause the tire to fall off during operation, which may cause an accident or rollover. Always ensure that all nuts are tightened to the required value (70~80)N·m. Do not use lubricating oil or grease on wheel bolts or wheel nuts. Lubricating oil or grease may cause excessive tightening of wheel nuts, resulting in damage to bolt or spoke wheels. In addition, lubricating oil or grease can cause wheel nuts to become loose and wheels may fall off, which can lead to accidents and serious injuries. Remove any lubricating oil or grease from wheel bolts or wheel nuts.

Tire replacement

WARNING

Do not use wheels of different sizes than recommended in the User's Manual as this can cause the vehicle to lose control.

The recommended size	The front wheel	The rear wheel
	25×8-12/26×8-12 /26×8-14	25×10-12/26×10-12 /26×10-14

SHOCK ABSORBER ADJUSTMENT

There are different kinds of shock absorber fitted in ATV depend on different configuration, please adjust the shock absorber according the actual kind fitted in your ATV.

Oil shock absorber

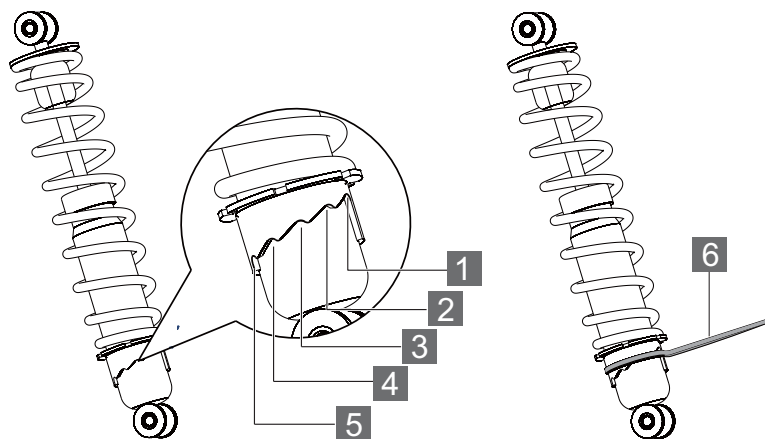

1. There are 5 shock absorption positions, which are used for different loads or driving conditions;

Position 1 : For light load or flat terrain;

Position 2 : Standard position;

Position 3 ~ 5 : When ATV load is heavy, it can be adjusted to this position;

2. Use crescent wrench **6** to adjust the impact spring pressure;

⚠ CAUTION

When adjusting the shock absorption position, always adjust the left and right shock absorption to the same position; Step up or down one position at a time during adjustment. Do not try to make large adjustments, which may damage the shock absorber.

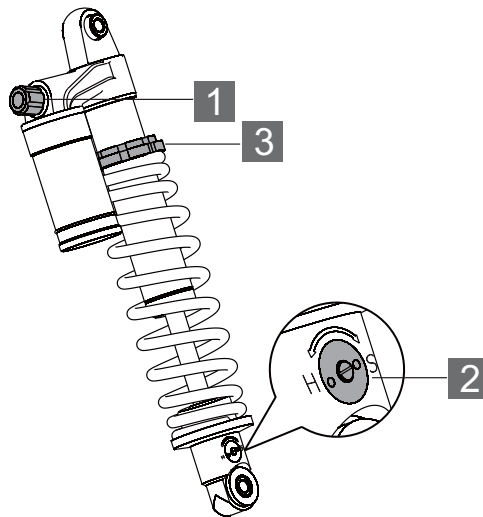
Adjustable air shock absorber

1 Compression damping adjusting knob

- ◆ Increase the compression damping when turn the knob clockwise
- ◆ Reduce the compression damping when turn the knob anticlockwise

2 Recovery of damping adjusting valve Use “-” screwdriver to adjust the valve

- ◆ Increase the recovery of damping when turn the valve to the direction of “H”
- ◆ Reduce the recovery of damping when turn the valve to the direction of “S”

3 Spring adjusting cap. Use special tool to adjust the spring adjusting cap

- ◆ Reduce the compression pressure when turn the adjusting cap upwards
- ◆ Increase the compression pressure when turn the adjusting cap downwards

SUSPENSION DRIVE LUBRICATION

The vehicle's front suspension, rear suspension, drive shaft and balance parts are reserved with grease nozzles, A grease filling label is posted nearby.

Grease filling label

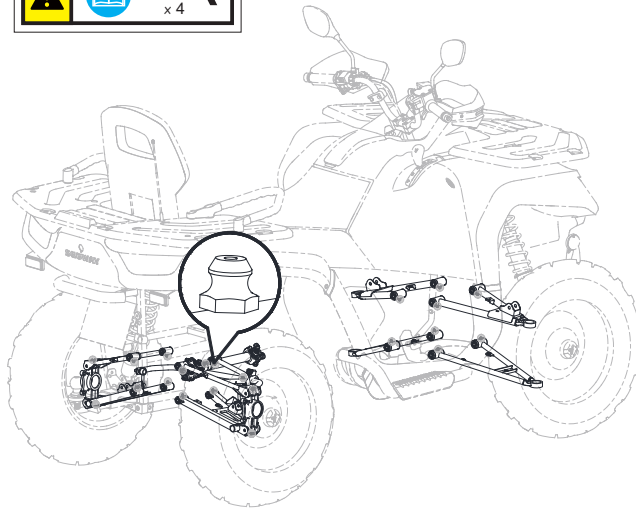

These parts in the vehicle needs sufficient lubrication, according to the maintenance of the periodic table to add appropriate grease, lubrication, can reduce the wear of these parts, and increase the service life.

DRIVENTRAIN BOOTS

Front Driveshaft Boots

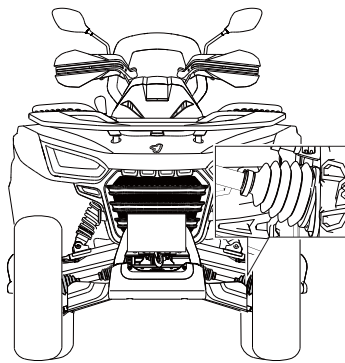

Rear Driveshaft Boots

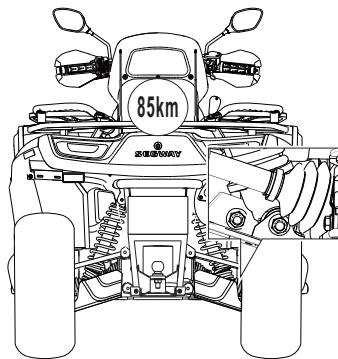

Check front and rear drive shaft dust jacket for cut, damage or grease leakage. If needed, please contact the dealer for replacement.

AIR FILTER

The air filter element of this vehicle is paper air filter element. The air filter needs to be cleaned or replaced after being used for a period of time. See the periodic maintenance table (see page 104) for details. First, remove the filter element for inspection. If the filter element is seriously soaked with oil or ash, do not clean it. Instead, replace it with a new filter element. If there is no oil or heavy ash, you can put the intake side down, knock on the ground, and shake off most of the dust.

It is better if you have an air pump, you can blow from the filter element side (cannot blow from the air intake side) until the dust is blown off.

Remove the empty filter cover

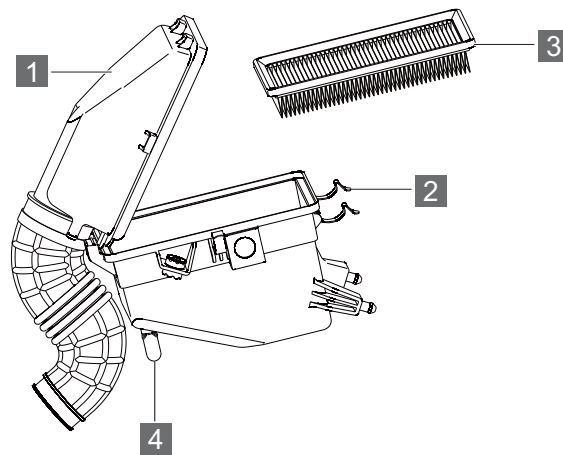

- 1 Air filter cover**
- 2 Air box cover clamp**
- 3 The filter element**
- 4 Air filter plug**

The air filter cover is located in front of the seat;
Disassembly steps (See page 108~109)

1. Press and move the air box cover clamp.
2. Pull up the front air filter cover;
3. Take out the old air filter.
4. Clean the filter;
5. Install a new filter if necessary.
6. Make sure the air filter is securely anchored.

LAMP

⚠ CAUTION

Poor lighting can result in reduced visibility while driving. If the headlight and taillight lenses get dirty, please clean the headlamps frequently and replace burnt headlamps promptly. To ensure optimum visibility, make sure the lights are properly adjusted.

Change the headlight

LED lights

LED lights consist of multiple lights. If any LED burns out, please send the vehicle to the dealer for replacement.

Halogen lamp

If the halogen bulb is damaged, it can be replaced. You can replace the following lamps yourself. The ease of replacement varies according to the bulb types. Due to possible damage, we recommend that the parts are better to be replaced by the dealers.

In the following cases, contact your dealer for more information. It doesn't mean malfunction if condensed water appears inside the headlamp lens temporarily.

- ◆ There are big beads of water inside the lens.
- ◆ Condensation of water inside the headlamp.

⚠ CAUTION

Hot ingredients can cause skin burns. Allow the lights to cool before doing maintenance.

DO NOT touch the headlight shade bulb glass. Fingerprints on the glass can cause premature failure.

Execute the following procedure:

1. Remove the headlamp shade expansion screw and remove the headlamp cover with the tool.

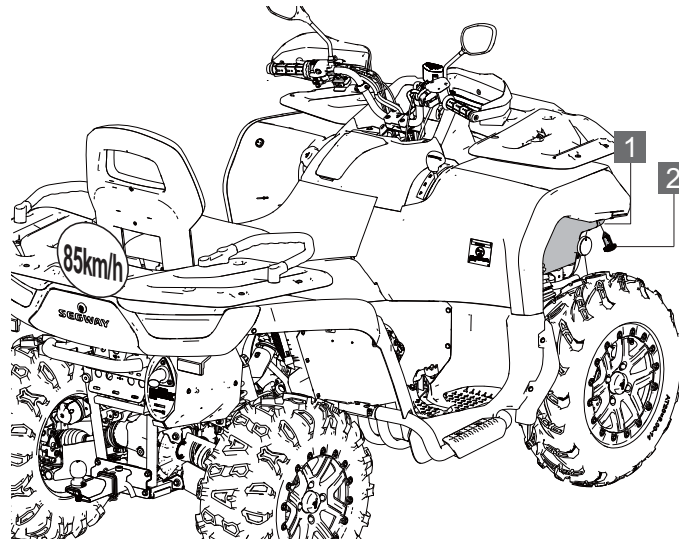

1 Front headlamps cover **2** expansion screw

2. Twist clockwise and turn off the cover of the headlamp.
3. Remove the wire harness connector on lamp and take out the broken lamp;

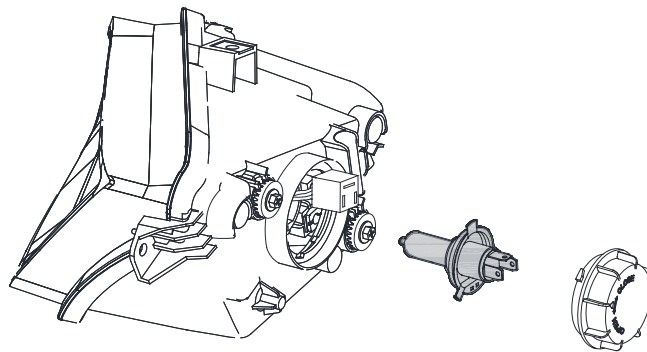

4. Reinstall the new light into the new headlight and turn on the headlight.

Test whether Lamp is working properly.

5. Press the fixed spring on both sides to make the spring pop out of the slot;
6. Remove the broken light bulb

⚠ CAUTION

Please replace lamp with the recommended power.

Reinstall the new lamp into the new headlight assembly. The installation procedure is opposite to the disassembly procedure. After installation, turn on the headlight switch to test whether the lamp is working properly.

Replace taillight/rear turn light

Procedures for changing taillights:

Remove rear light cover.

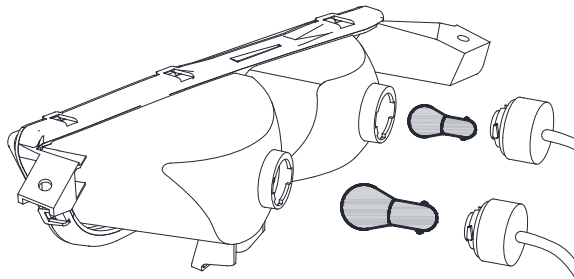

1. Unscrew the rear light holder.
2. Turn the bulb that needs to be replaced on the taillight seat from left to right. When the limit bead at the end of the bulb gets stuck in the limit slot of the lamp seat, the damaged bulb can be taken out and replaced with a new bulb with the same power.
3. Test whether the lamp works normally.

High beam adjustment

The headlight beam can be adjusted slightly up/down. Use the following procedure to make adjustments.

⚠ CAUTION

The following pictures are for reference only. Your model may be slightly different.

It is best to let Segway Powersports dealers adjust if conditions permit.

1. Place the vehicle on a horizontal plane with a headlight position of about 10M.

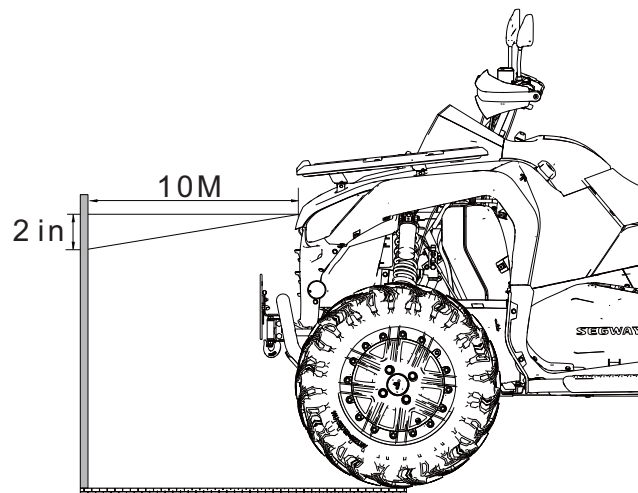

2. Measure the distance from the floor to the center of the headlights and mark the walls at the same height.
3. Start the engine. Convert headlight switch to high beam.
4. Watch the headlights aim at the wall. The strongest part of the headlight beam should be 2 inches, 5cm below the mark on the corner. Measurement on the seat includes weight of the driver.

Adjust the headlight beam upwards and downwards

To raise the headlight beam, turn the headlight adjusting screw counterclockwise.

To lower the headlight beam, turn the headlight speed adjustment screw clockwise.

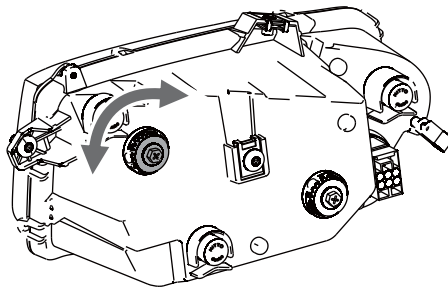
**1 Light adjusting screw**

Adjust the headlight beam left and right

Headlight beam can be adjusted slightly to the left or right.

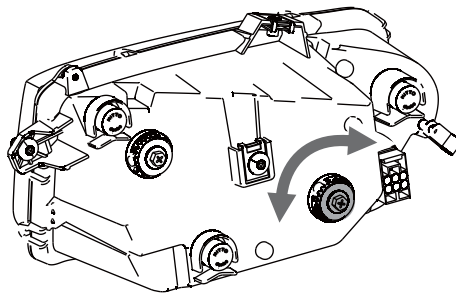
**1 Light adjusting screw**

To turn the headlight beam to the left, turn the headlight adjustment screw counterclockwise.

To turn the headlight beam to the right, turn the headlight speed adjustment screw clockwise.

SPARK PLUG

Refer to the recommended spark plug type and clearance specifications. Spark plug torque specification.

⚠ CAUTION

Using unrecommended spark plugs can cause serious engine damage. Always use the recommended spark plugs or their equivalents.

Spark Plug	Model	spark plug clearance
	CPR7EA/B7RTC	0.6-0.8mm

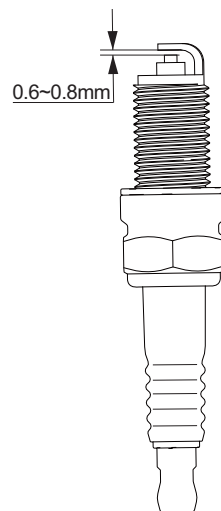

Spark plug inspection

Spark plug condition indicates engine running. Check or change the spark plugs with reference to the maintenance time of the periodic maintenance schedule.

⚠ CAUTION

Remove the spark plug for inspection need wear protective gloves, or hot exhaust system and engine will cause burns.

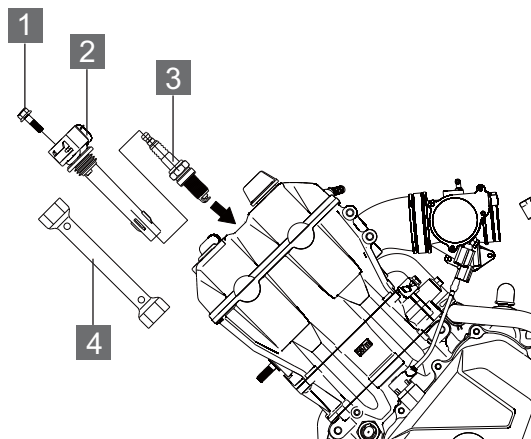

1 Bolt

2 Ignition coil

3 Spark plug

4 Spark plug sleeve

The spark plug is located under the cushion, please refer to page 108 for removing the cushion.

1. Remove the ignition coil fixing bolts;
2. Take out the ignition coil;
3. The spark plug is located below the ignition coil. Use tool to turn the spark plug cap 1/4 and remove it from the spark plug.
4. Rotate the spark plug counterclockwise and remove it.
5. Inspect the spark plug

Spark plug normal status: The electrode part is grayish white, grayish yellow or light brown, and the electrode gap is about 0.6-0.8mm.

Spark plug to be replaced: The spark plug appears electrode ablation, carbon deposition, clearance is too large, at this time the spark plug should be replaced.

SPARK ARRESTER

Spark eliminator prevents random sparks from entering other vehicles parts. Regular maintenance can prevent carbon accumulation, whereas delayed maintenance will reduce engine performance.

WARNING

Make sure the exhaust pipes are cool and the engine has just stopped running. Let pipes completely cool down to avoid getting burned.

To reduce fire hazards, ensure that there are no combustible material in the area when removing spark plugs.

Safety glasses are recommended in this procedure.

The exhaust pipe must be cleaned of accumulated carbon periodically as follows:

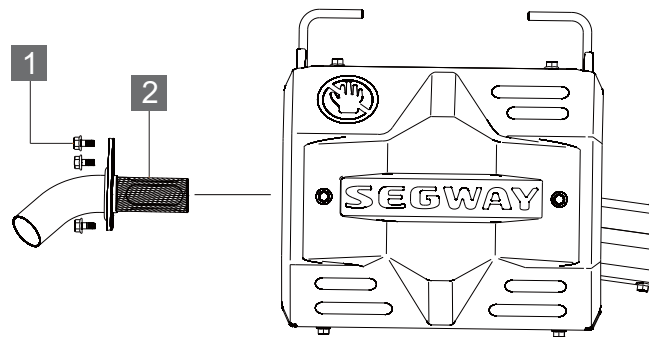

1 Bolt M6*16 (3 PC) **2 Muffler spark eliminator**

1. Remove 3 pieces of M6*16 bolts.
2. Start the engine and rev it up about 20 times, At the same time, use a towel to plug the end of the muffler, instantly generate exhaust system pressure;
3. Make the engine exhaust pipe to cool.
4. Reinstall the muffler spark eliminator and bolts.

BATTERY

Due to natural discharge and leakage effects of some electrical equipment, the 12V battery will discharge gradually even when the vehicle is not in use. If the vehicle is parked for a long time, the 12V battery may discharge and may not start. Please charge the battery slowly one time for at least within 30 days. This will maintain the battery life.

WARNING

12V batteries contain toxic and corrosive sulfuric acid and may produce flammable explosive hydrogen gas. To reduce the risk of serious injury or death, the following precautions should be observed when handling 12V batteries or working near them:

- ◆ Do not smoke or light a match near a 12V battery.
- ◆ Avoid splashing electrolyte on eyes, skin and clothes.
- ◆ Wear safety goggles when working near 12V battery.
- ◆ Keep children away from 12V batteries.

Be sure to charge the 12V battery in an open area. Do not charge a 12V battery in a poorly ventilated garage or enclosed room.

Battery disassembly

NOTICE

If the electrolyte overflows, immediately wash it off with a solution of 1 tablespoon baking soda and 1 cup water to prevent damage to the vehicle.

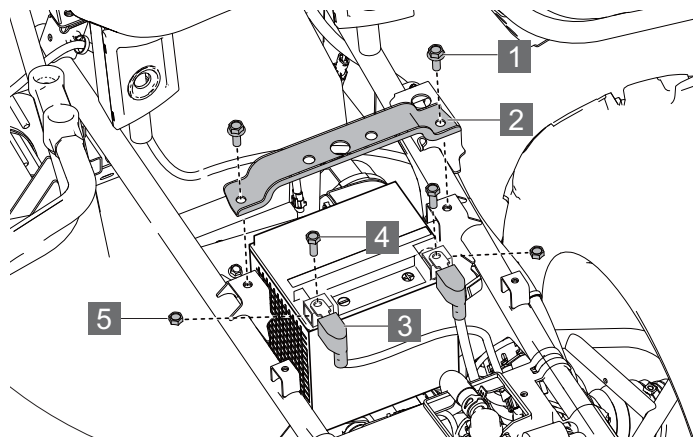

The battery is located below the cushion. Please refer to page 108 for removing the cushion.

Cut off the power before removing battery;

- 1 Bolt M8*12 (2 PC)**
- 2 Battery plate**
- 3 Protective rubber sleeve**
- 4 Positive and negative anchor bolts for cable**
- 5 Positive and negative anchor nuts for cable**

1. Remove the battery cover screw **1** with a tool;
2. Remove battery press plate **2** ;
3. Turn up the Protective rubber sleeve;
4. Remove the battery negative pole screw and disconnect the black (negative) battery cable.
5. Remove the battery positive pole screw and disconnect the red (positive) battery cable.
6. Remove the battery from the ATV.

Battery Charging

CAUTION

When charging, the hydrogen produced by the 12V battery is combustible explosive gas. Therefore, please follow the following precautions before charging:

If charging the 12V battery is still installed in the vehicle, be sure to disconnect the ground cable.

Make sure the power switch on the charger is off when connecting and disconnecting the charger cable to the 12V battery.

Only charge slowly (5A or less). If charged quickly, the 12V battery may explode.

Measures to be taken in an emergency

1. Connect the clamp of the positive jumper cable to the special jumper starting terminal of the vehicle.
2. Connect the clamp on the other end of the positive cable to the positive (+) terminal of another vehicle.
3. Connect the negative cable clamp to the negative battery terminal of another vehicle.
4. As shown, connect the clamp on the other end of the negative cable to a separate clamp.

Bonded starting terminals and any moving parts of a firm, stable, unpainted metal end on.

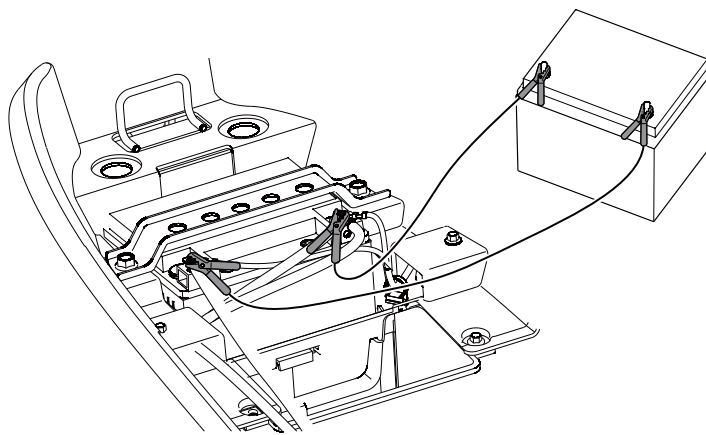

Battery installation

NOTICE

To reduce the chance of sparks: Whenever the battery is removed, disconnect the black (negative) cable first. When reinstalling the battery, finally install the black (negative) cable.

1. Clean battery cables and terminals with a hard wire brush. Corrosion can be removed with a solution of 1 cup water and 1 tablespoon baking soda. Rinse well and dry thoroughly.
2. Put the battery in the tray.
3. Connect and tighten the red (positive) cable.
4. Connect and tighten the black (negative) cable.
5. Install a clear battery vent from the vehicle to the battery vent. (For conventional batteries only).
6. Install the battery press plate;
7. Tighten the battery clamp bolt;
8. Verify that cables are properly wired.

FUSE

All circuits on the ATV have fuses to protect electrical equipment from damage caused by high current (short circuit or overload).

If any of the electrical parts do not work, the fuse may have blown. If this happens, check and replace the fuse if necessary. You can consider electrical faults. First check whether the fuse needs to be replaced, if it is found to have blown, replace the blown fuse. There is a spare fuse in the fuse box. Check all fuses for other possible causes. Replace all blown fuses and check the working condition of components. All fuses are concentrated in the fuse box. In the event of a system failure, see "Fuse Distribution and Ampere rating" for details of which fuses to check.

NOTICE

- ◆ Do not use a fuse above the rated ampere value or replace it with anything else.
- ◆ Please use the same product. Never use wires for fuses, even temporary replacements are not allowed.
- ◆ Do not modify fuses or fuse boxes.

Fuse box

The fuse box is located under the front instrument mask.

Remove front panel repair cover as shown in page 110.

After the front panel repair cover is removed, the fuse box located at the bottom can be seen. Move the clasp on the left and right sides of the fuse box cover to the outside. Loosen the clasp and open the fuse box.

NOTICE

Fuse box cover with limited slot, please pay attention to the direction of installation.

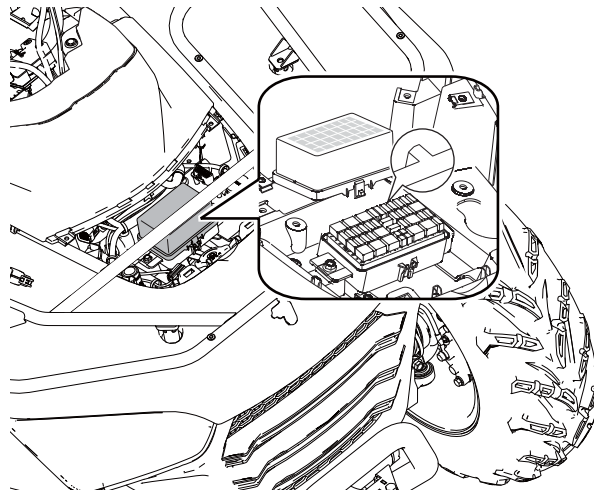

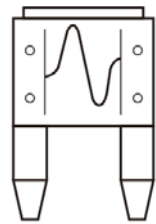

Normal fuse

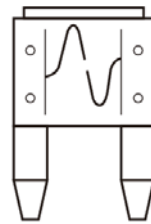

Blow fuse

Fuse/relay distribution and rated amperage

There is a fuse distribution label on the top of the fuse box cover. You can refer to the fuse power on the label to find a fuse of the same power for replacement.

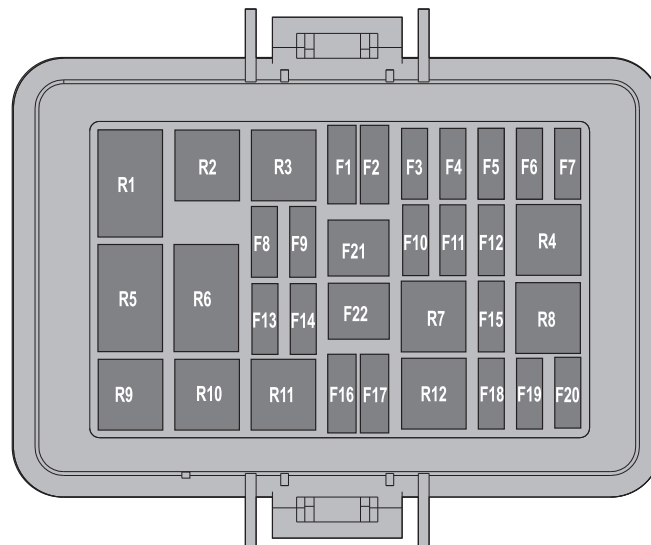

Rated amperage of fuse/relay and distribution

No.	Fuse/Relay	Power
F1	Buzzer and OBD ICU	5A
F2	Start ECU	5A
F3	Flameout Switch	10A
F4	2WD / 4WD	10A (No differential)
		20A (With differential)
F5	Light speaker	15A
F6	ICU-IG	7.5A
F7	DTS-IG	5A
F8	DTS	5A
F9	Power lock	5A
F10	EPS-IG	5A
F11	12V/USB power output seat	15A
F12	Pos-Lamp-L	7.5A
F13	Fuel pump	10A
F14	Heat light	25A
F15	Pos-Lamp-R	7.5A
F16	Fan	15A
F17	Fuel injector	10A
F18	ECU	10A
F19	Oxygen sensor	10A

F20	Coil	10A
F21	The main fuse	30A or 50A
F22	EPS	50A
R1	2WD/4WD relay 1	12V 20A
R2	DTS relay	12V 20A
R3	IG relay	12V 20A
R4	Main relay	12V 20A
R5	2WD/4WD relay 2	12V 20A
R6	ECU-4WD relay (optional equipment)	12V 20A
R7	Lower beam relay	12V 20A
R8	High beam relay	12V 20A
R9	Auxiliary starting relay	12V 20A
R10	Day light relay	12V 20A
R11	Fuel pump relay	12V 20A
R12	Fan relay	12V 20A

NOTICE

Due to the continuous upgrading of products, the fuse may have slight changes. All functional positions and specifications in the fuse box are subject to the actual product.

Fuse box replacement

To prevent an accidental short circuit, turn the ignition switch to the (OFF) position and check or replace the fuse.

To check or replace the circuit fuse, pull out the old fuse with a puller.

The fuse box cover is equipped with a puller. Using this tool will help you take out the fuse;

The fuse box cover is fitted with a common fuse which can be replaced.

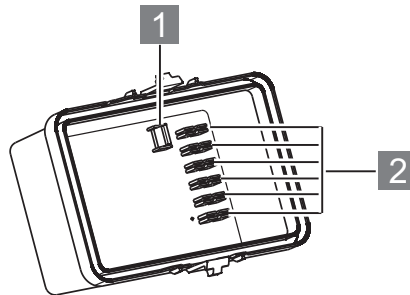

1 Puller

2 Spare fuse

NOTICE

If a replacement fuse suitable for the circuit rating is not available, install a lower rated fuse.

APPEARANCE CARE

High pressure water can damage parts and remove paint and decals.

1. Cover or plug the exhaust outlet prior to washing your ATV.
2. Fill a bucket with water. Mix in a mild, neutral detergent, such as dish washing liquid or a product made especially for washing motorcycles or automobiles.
3. Wash your ATV with a sponge or soft towel. As you wash, check for heavy grime. If necessary, use a mild cleaner/degreaser to remove the grime.
4. After washing, rinse your ATV thoroughly with plenty of clean water to remove any residue. Detergent residue can corrode alloy parts.
5. Dry your ATV with a chamois or a soft towel. Leaving water on the surface to air dry can cause dulling and water spots. As you dry, inspect for chips and scratches.
6. As a precaution, ride your ATV at a slow speed and apply the brakes several times. This will help dry the brakes and restore normal braking performance.

Cleaning vehicles

Wash the vehicle immediately after driving in salty or corrosive environment.

It is recommended that you clean your vehicle with regular aerosols. Follow the instructions on the container.

Cleaning tips

Avoid using automotive products, some of which may scratch your vehicle. Clean and polish regularly with a clean cloth and mat. Old or reused cloth and mats can contain dirt particles that can scratch the finish.

Vehicle storage

When the vehicle is not used for a long time, it should be appropriately stored. The vehicle should be parked and cleaned. If there is no indoor storage conditions, covered outdoor storage is recommended.



SPECIFICATIONS

TECHNICAL PARAMETERS OF VEHICLE.....	169
VEHICLE IDENTIFICATION NUMBER.....	174
THE FRAME NAMEPLATE.....	175

TECHNICAL PARAMETERS OF VEHICLE**SGW570F-A3/SGW570F-A6**

No.	Item	Model	
		SGW570F-A3	SGW570F-A6
1	Length	2200mm	2350mm
2	Width	1280mm	1280mm
3	Height	1320mm	1430mm
4	Wheel base	1300mm	1450mm
5	Ground clearance	270mm	270mm
6	Turning diameter	7000mm	8000mm
7	Curb weight (no oil and gasoline)	390kg	398kg
8	Front rack load	40kg	
9	Rear rack load	60kg	
10	Recommended Traction quality Pulled load quality)	300kg	350kg
11	Engine model	199MS	
12	Engine type	Four stroke、Single cylinder、Water cooled、vertical、Double overhead camshaft	

SPECIFICATIONS

SEGWAY

13	Cylinder diameter × stroke	99×73.6
14	Engine displacement	567ml
15	Compression ratio	10.6:1
16	Maximum power	32.5kw / 7000 rpm
17	Maximum torque	48N·m / 5500 rpm
18	Idle speed	1400±140r/min
19	Starting way	Electric start
20	Lubrication way	Pressure spray
21	Engine oil type	10W/40-SJ
22	Engine oil capacity (oil filter replacement)	2.4L
23	Engine oil capacity (The filter not changed)	2.2L
24	Front axle gear oil type	SAE 75W/90/GL-5 or SAE 80W/90/GL-5
25	Change the volume	280ml

26	Rear axle gear oil model	SAE 75W/90/GL-5 or SAE 80W/90/GL-5
27	Change the volume	220mL (No differential) 260mL (With differential)
28	Air filter	Paper filter
29	Fuel tank type	Fame-retardant plastic fuel tank
30	Fuel tank capacity	23L
31	Fuel storage capacity	4.5L
32	Throttle type	D42
33	Spark plug type	CPR7EA / B7RTC
34	Spark plug clearance	0.6~0.8mm
35	Variable speed way	CVT infinitely variable speed
36	Shift sequence	L-H-N-R-P
37	Variable speed ratio	0.648~2.976
38	L Transmission ratio	5.34
39	H Transmission ratio	3.08
40	Reverse gear ratio	4.40
41	Tire type	Vacuum tire
42	Front tire specification	25×8-12/26×8-12/26×8-14

SPECIFICATIONS

SEGWAY

43	Rear tire specification	25×10-12/26×10-12/26×10-14
44	Front tire pressure	48.3kPa
45	Rear tire pressure	48.3kPa
46	Brake type	front double disc brake, rear single disc brake(Brake shaft)/front double disc brake、 rear double brake
47	Foot brake mode	Right foot operation
48	Front braking mode	right operation
49	Brake fluid type	DOT4
50	Front suspension	Front double A rocker arm
51	Rear suspension	Rear double A rocker arm
52	Front shock absorber form	Spring + oil resistance Spring + air resistance
53	Rear shock absorber form	Spring + oil resistance Spring + air resistance
54	Front wheel travel	185mm
55	Rear wheel travel	210mm
56	Ignition mode	electricity (ECU)
57	Charge	450W / 5500 rpm
58	Battery	12V 32Ah

Light(2 status)			
59	Headlight	LED 13.2W	H4 55W/60W
60	Front turn light	LED 2.64W	4.8W
61	Day light	LED 28.8W	4.2W
62	Front position light	LED 12W	0.5W
63	Ear turn light	LED 2.64W	10W
64	Parking light	LED 3.96W	21W
65	Rear tail light	LED 0.61W	10W/5W
66	License plate light	5W	

VEHICLE IDENTIFICATION NUMBER

Record the frame identification code and engine serial code in the spaces provided for assistance when ordering spare parts from a dealer or for reference in case the vehicle is stolen.

The frame identification number is located on the frame cross under the seat cushion pipe under the seat cushion.

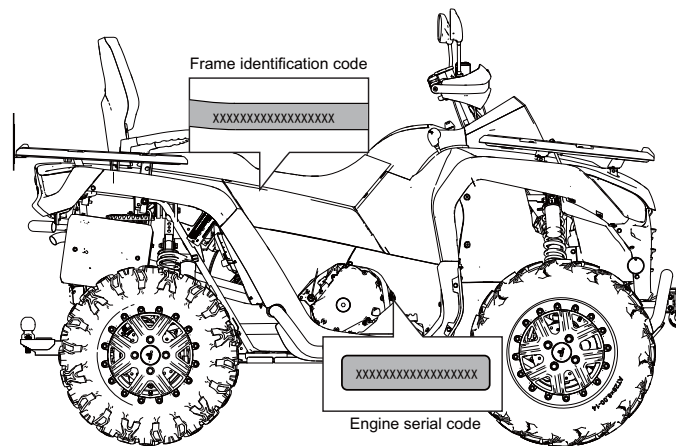

Frame identification code	
---------------------------	--

Engine serial code	
--------------------	--

THE FRAME NAMEPLATE

The frame nameplate is located below the right rear shelf of the vehicle, the nameplate shows the basic characteristics information which include VIN code. It needs the VIN when the vehicle requires activate in the first time.

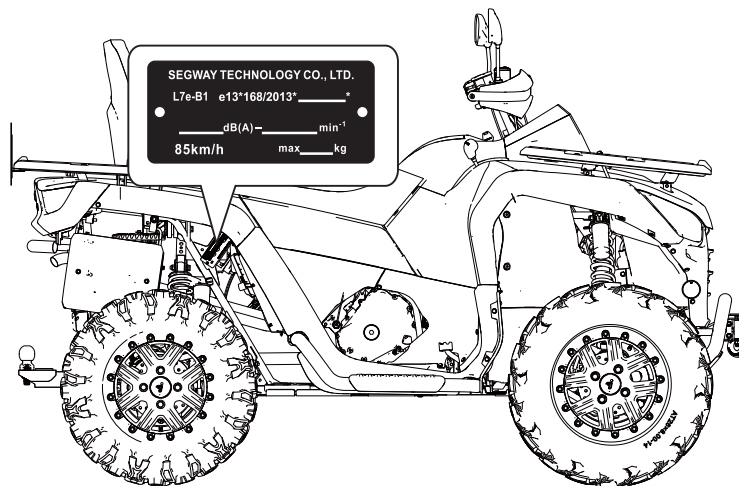



TROUBLESHOOTING

Drive belt and cover problems.....	177
Engine doesn't turn over.....	180
Engine pings or knocks.....	180
Engine stops or loses power.....	181
Engine turns over, fails to start.....	181
Engine backfires.....	182
Engine runs irregularly, stalls or misfires.....	183
Engine runs irregularly, stalls or misfires.....	183
Engine stops or loses power.....	185

With all the challenges you can encounter off-road, there's a chance that sometime something may go wrong. This section gives practical advice to help you deal with a wide range of problems. Take time to read this section before you ride.

Drive belt and cover problems

Possible Cause	Solution
Driving the ATV onto a pickup or tall trailer in high range	Shift transmission to low range during loading of the ATV to prevent belt burning
Starting out going up a steep incline	When starting out on an incline, use low range or dismount the ATV (after first applying the park brake) and perform the K-turn as described on page 71
Driving at low RPM or low ground speed (at approximately 5-10 km/h)	Drive at a higher speed or use low range more frequently. The use of low range is highly recommended for cooler CVT operating temperatures and longer component life
Insufficient warm-up of ATVs exposed to low ambient temperatures	Warm the engine before driving, the belt will become more flexible and prevent belt burning

TROUBLESHOOTING

SEGWAY

Slow and easy clutch engagement	Use the throttle quickly and effectively for efficient engagement
Towing/pushing at low RPM/low ground speed	Use low range only
Utility use/plowing snow, dirt, etc	Use low range only

Possible Cause	Solution
Stuck in mud or snow	Shift the transmission to low range, and carefully use fast, aggressive throttle application to engage clutch. WARNING: Excessive throttle may cause loss of control and vehicle overturn
Climbing over large objects from a stopped position	Shift the transmission to low range, and carefully use fast, brief, aggressive throttle application to engage clutch. Excessive throttle may cause loss of control and vehicle overturn
Belt slippage from water or snow ingestion into the CVT system	Remove the CVT cover, drain the water from CVT
Clutch malfunction	Contact your dealer for inspection of clutch components

Engine doesn't turn over

Possible Cause	Solution
Poor engine performance	Check for fouled plugs or foreign material in gas tank, fuel lines, or throttle. Contact your dealer for service.
Tripped circuit breaker	Reset the breaker
Low battery voltage	Recharge battery to 12.5 VDC
Loose battery connections	Check all connections and tighten
Loose solenoid connections	Check all connections and tighten

Engine pings or knocks

Possible Cause	Solution
Poor quality or low octane fuel	Replace with recommended fuel
Incorrect ignition timing	See your dealer
Correct spark plug gap or heat range	Set gap to specs or replace plugs

Engine stops or loses power

Possible Cause	Solution
Overheated engine	Clean radiator screen and core if equipped Clean engine exterior See your dealer

Engine turns over, fails to start

Possible Cause	Solution
Out of Fuel	Refuel
Clogged fuel valve or filter	Inspect and clean or replace
Water is present in fuel	Drain the fuel system and refuel
Fuel valve is out of use	Replace
Old or non-recommended fuel	Replace with new fuel
Fouled or defective spark plug(s)	Inspect plug(s), replace if necessary
No spark to spark plug	Inspect plug(s), verify stop switch is on
Crankcase filled with water or fuel	Immediately see your dealer

TROUBLESHOOTING

SEGWAY

Overuse of choke	Inspect, clean and/or replace spark plugs
Clogged fuel injector	Clean or replace new fuel injector
Low battery voltage	Recharge battery to 12.5 VDC
Mechanical failure	See your dealer

Engine backfires

Possible Cause	Solution
Weak spark from spark plugs	Inspect, clean and/or replace spark plugs
Incorrect spark plug gap or heat range	Set gap to specs or replace plugs
Old or non-recommended fuel	Replace with new fuel
Incorrectly installed spark plug wires	See your dealer
Incorrect ignition timing	See your dealer
Mechanical failure	See your dealer

Engine runs irregularly, stalls or misfires

Possible Cause	Solution
Fouled or defective spark plugs	Inspect, clean and/or replace spark plugs
Worn or defective spark plug wires	See your dealer
Incorrect spark plug gap or heat range	Set gap to specs or replace plugs
Loose ignition connections	Check all connections and tighten
Water present in fuel	Replace with new fuel
Low battery voltage	Recharge battery to 12.5 VDC

Engine runs irregularly, stalls or misfires

Possible Cause	Solution
Kinked or plugged fuel vent line	Inspect and replace
Incorrect fuel	Replace with recommended fuel
Clogged air filter	Inspect and clean or replace
Reverse speed limiter malfunction	See your dealer

TROUBLESHOOTING

SEGWAY

Electronic throttle control malfunction	See your dealer
Other mechanical failure	See your dealer
Possible Lean or Rich Fuel Mixture Cause	Solution
Low or contaminated fuel	Add or change fuel, clean the fuel system
Low octane fuel	Replace with recommended fuel
Clogged fuel filter	Replace filter
Incorrect jetting	See your dealer
Overuse of choke	Inspect, clean and/or replace spark plugs
Fuel is very high octane	Replace with lower octane fuel

Engine stops or loses power

Possible Cause	Solution
Out of fuel	refuel
Kinked or plugged fuel vent line	Inspect and replace
Water present in fuel	Replace with new fuel
Overuse of choke	Inspect, clean and/or replace spark plugs
Fouled or defective spark plugs	Inspect, clean and/or replace spark plugs
Worn or defective spark plug wires	See your dealer
Incorrect spark plug gap or heat range	Set gap to specs or replace plugs
Loose ignition connections	Check all connections and tighten
Low battery voltage	Recharge battery to 12.5 VDC
Clogged air filter	Inspect and clean or replace
Reverse speed limiter malfunction	See your dealer
Electronic throttle control malfunction	See your dealer
Other mechanical failure	See your dealer



EMISSION CONTROL SYSTEM

SOURCE OF EXHAUST EMISSIONS.....187

EXHAUST EMISSION CONTROL SYSTEM.....187

CRANKCASE EMISSION CONTROL SYSTEM.....188

NOISE CONTROL SYSTEM.....188

SOURCE OF EXHAUST EMISSIONS

The combustion process produces carbon monoxide(CO), oxides of nitrogen(NO_x)and hydrocarbons(HC). Control of hydrocarbons and oxides of nitrogen is very important because, under certain conditions, they react to form photochemical smog when subjected to sunlight. Carbon monoxide does not react in the same way, but it is toxic.

EXHAUST EMISSION CONTROL SYSTEM

The exhaust emission control system includes a PGM-F system and oxygen sensor.

No adjustments to this system should be made although periodic inspection of the components is recommended.

The exhaust emission control system is separate from the crankcase emission control system.

CRANKCASE EMISSION CONTROL SYSTEM

The engine is equipped with a closed crankcase system to prevent discharging crankcase emissions into the atmosphere. Blow-by gas is returned to the combustion chamber through the air cleaner.

NOISE CONTROL SYSTEM

Do not modify the engine, air intake or exhaust components, in order to meet local noise level requirements.

WARRANTY

LIMITED WARRANTY.....	190
REGISTRATION.....	190
EXCLUSIONS-ARE NOT WARRANTED.....	191
LIMITATIONS OF WARRANTIES AND REMEDIES...192	
MAINTENANCE LOG.....	195

LIMITED WARRANTY

SEGWAY TECHNOLOGY CO., LTD gives a LIMITED WARRANTY on components of your new SEGWAY vehicle against defects in parts or workmanship when properly set up and operated in accordance with the recommendations set forth in the SEGWAY Owner's Manual. SEGWAY gives a TWO (2) YEAR limited warranty for use of the vehicle. For commercial use, SEGWAY gives a SIX (6) MONTHS limited warranty. This warranty covers parts and labor charges for repair or replacement of defective parts and begins on the date of purchase by the original retail purchaser.

This warranty is transferable to another owner during the warranty period through a SEGWAY dealer, but any such transfer will not extend the original term of the warranty. The duration of this warranty may vary by international region based upon local laws and regulations.

REGISTRATION

At the time of sale, the Warranty Registration Form must be completed by your dealer and submitted to SEGWAY within ten days of purchase. Upon receipt of this registration, SEGWAY will record the registration for warranty.

EXCLUSIONS-ARE NOT WARRANTED

The following are not warranted under any circumstances:

1. Normal wear and tear.
2. Routine maintenance items, tune-ups, adjustments.
3. Damage caused by failure to provide proper maintenance and/or storage, as described in the Owner's Manual.
4. Damage resulting from removal of parts, improper repairs, service, maintenance, or use of parts not manufactured or approved by SEGWAY or resulting from repairs done by a person that is not an authorized servicing SEGWAY dealer.
5. Damage caused by abuse, abnormal use, neglect or operation of the product in a manner inconsistent with the recommended operation described in the Owner's Manual.
6. Damage resulting from accident, submersion, fire, theft, vandalism or any force majeure.
7. Operation with fuels, oils or lubricants which are not suitable for use with the product. (see the section "Technical parameters of vehicle "on Owner's Manual).
8. Damages from rust, corrosion resulted from salty water or corrosive material.
9. Damage resulting from the racing or any other competitive activity.

10. Damage resulting from the vehicle has been altered or modified in such a way so as to adversely affect its operation, performance or durability, or has been altered or modified to change its intended use.

LIMITATIONS OF WARRANTIES AND REMEDIES

This limited warranty excludes any failures that are not caused by a defect in material or workmanship. This warranty provides no coverage for consumable components, general wear items, or any parts exposed to friction surfaces, stresses, environmental conditions and/or contamination for which they were not designed or not intended, including but not limited to the following items:

- Batteries
- Bearings
- Brake components
- Bushings
- Throttle body components
- Circuit breakers/fuses
- Clutches components
- Coolants
- Drive belts
- Filters
- Finished/unfinished surfaces
- Hydraulic components/fluids
- Light bulbs/lamps
- Lubricants
- Sealants
- Seat components
- Spark plugs
- Steering components

- Electronic components
- Engine components
- Suspension components
- Wheels and tires

This warranty provides no coverage for personal loss or expense, including mileage, transportation costs, hotels, meals, shipping or handling fees, product pick-up or delivery, replacement rentals, loss of product use, loss of profits, or loss of vacation or personal time.

THE EXCLUSIVE REMEDY FOR BREACH OF THIS WARRANTY SHALL BE, AT SEGWAY' OPTION, REPAIR OR REPLACEMENT OF ANY DEFECTIVE MATERIALS, COMPONENTS, OR PRODUCTS. THE REMEDIES SET FORTH IN THIS WARRANTY ARE THE ONLY REMEDIES AVAILABLE TO ANY PERSON FOR BREACH OF THIS WARRANTY. SEGWAY SHALL HAVE NO LIABILITY TO ANY PERSON FOR INCIDENTAL, CONSEQUENTIAL OR SPECIAL DAMAGES OF ANY DESCRIPTION, WHETHER ARISING OUT OF EXPRESS OR IMPLIED WARRANTY OR ANY OTHER CONTRACT, NEGLIGENCE, OR OTHER TORT OR OTHERWISE. THIS EXCLUSION OF CONSEQUENTIAL, INCIDENTAL, AND SPECIAL DAMAGES IS INDEPENDENT FROM AND SHALL SURVIVE ANY FINDING THAT THE EXCLUSIVE REMEDY FAILED OF ITS ESSENTIAL PURPOSE. THE IMPLIED WARRANTY OF FITNESS FOR A PARTICULAR PURPOSE IS EXCLUDED FROM THIS LIMITED WARRANTY. ALL OTHER IMPLIED WARRANTIES (INCLUDING BUT NOT LIMITED TO THE IMPLIED WARRANTY OF MERCHANTABILITY) ARE LIMITED IN DURATION TO

WARRANTY

SEGWAY

THE ABOVE SIX MONTH WARRANTY PERIOD. SEGWAY DISCLAIMS ALL EXPRESS WARRANTIES NOT STATED IN THIS WARRANTY. SOME STATES DO NOT PERMIT THE EXCLUSION OR LIMITATION OF INCIDENTAL OR CONSEQUENTIAL DAMAGES OR ALLOW LIMITATIONS ON THE DURATION OF IMPLIED WARRANTIES, SO THE ABOVE LIMITATIONS MAY NOT APPLY TO YOU IF INCONSISTENT WITH CONTROLLING REGION LAW.

MAINTENANCE LOG

Use the following chart to record periodic maintenance.

VIN	Date	Miles(Km)or Hours	Service item