

⚠ WARNING

Read, understand, and follow all of the instructions and safety precautions in this manual and all product labels.

Failure to follow the safety precautions could result in serious injury or death.

⚠ WARNING

The engine exhaust from this product contains chemicals known to the State of California to cause cancer, birth defects or other reproductive harm.



SCAN CODE FOR PRODUCT AND SAFETY INFORMATION. FOLLOW ALL INSTRUCTIONS AND WARNINGS.

WARNING

Rollovers have caused severe injuries and death, even on flat, open areas. Be Sure Riders Pay Attention and Plan Ahead

If you think or feel the vehicle may tip or roll, reduce your risk of injury:

- Keep a firm grip on the steering wheel or handholds and brace yourself.
- Do not put any part of your body outside of the vehicle for any reason.



Drive Responsibly

Avoid loss of control and rollovers:

- Avoid abrupt maneuvers, sideways sliding, skidding or fishtailing, and never do donuts.
- Avoid hard acceleration when turning, even from a stop.
- Slow down before entering a turn.
- Plan for hills, rough terrain, ruts, and other changes in traction and terrain. Avoid paved surfaces.
- Avoid side hilling (riding across slopes).



Be Prepared

- Fasten seat belts and make sure nets or doors are securely latched in place.
- Wear an approved helmet and protective gear.
- Each rider must be able to sit with back against seat, feet flat on the floor, and hands on steering wheel or handholds. Stay completely inside the vehicle.



Require Proper Use of Your Vehicle

Do your part to prevent injuries:

- Do not allow careless or reckless driving.
- Make sure operators are 16 or older with a valid driver's license.
- Do not let people drive or ride after using alcohol or drugs.
- Do not allow operation on public roads (unless designated for off-highway vehicle access) – collisions with cars and trucks can occur.
- Do not exceed seating capacity: 1 passenger.



Never use on public roads

- On public roads - a collision can occur with another vehicle
- Never operate this vehicle on any public street, road or highway, even a dirt or gravel one.



Read and understand all safety labels, locate and read operator's manual.

S04L10006001

Segway Powersports Inc.

No. 395, Xiacheng South Road, Wujin National High-tech Industrial Development Zone, Changzhou, Jiangsu, China

For your nearest Segway dealer, visit : powersports.segway.com

WELCOME

Thank you for buying this Segway. (add a space) Segway off-road vehicles will bring you a new driving experience.

For your driving safety, read this manual before riding. This manual contains a large number of safety instructions, operation instructions, maintenance instructions and safety warnings.

Reading of this manual will help you quickly understand the vehicle and help you with safe driving practices.

Periodic maintenance procedures are included in this manual and should be performed regularly to keep your vehicle running safely.

IMPORTANT NOTICE

This vehicle is designed and manufactured for off-road use and complies with all applicable off-road noise, vibration, and emission regulations.

Before driving the vehicle, please understand the local laws and regulations, choose the allowed road for driving and, abide by the local traffic regulations.

This manual is applicable to the SSV fuel series and describes all equipment including optional components. Therefore, some of the optional equipment described in the manual may be not installed on your vehicle.

Bluetooth® is a registered trademark of Bluetooth Sig, Inc. QR Codes® is a registered trademark of DENSO WAVE INCORPORATED. Unless noted, trademarks are the property of Segway Powersports Inc.

Copyright 2020 Segway Powersports Inc. All information contained within this publication is based on the latest product information at the time of publication. Due to constant improvements in the design and quality of production components, some minor discrepancies may result between the actual vehicle and the information presented in this publication. Depictions and/or procedures in this publication are intended for reference use only. No liability can be accepted for omissions or inaccuracies. Any reprinting or reuse of the depictions and/or procedures contained within, whether whole or in part, is expressly prohibited.

If your vehicle needs any service and repair matters, please contact your dealer to provide service.

Visit <http://powersports.segway.com> for a list of dealers and service locations.



TABLE OF CONTENTS

SAFETY INTRODUCTION	1
VEHICLE DEVICE	2
OPERATION	3
MAINTENANCE, STORAGE AND TRANSPORTATION	4
SPECIFICATIONS	5
TROUBLESHOOTING	6
EMISSION CONTROL SYSTEM	7
WARRANTY	8

INTRODUCTION BEFORE YOU RIDE

This **SEGWAY** vehicle is an off-road vehicle. Familiarize yourself with all laws and regulations concerning the operation of this vehicle in your area.

WARNING

Failure to adhere the warnings and safety precautions contained in this manual will result in severe injury or death. Your SEGWAY vehicle is not toy and it can be hazardous to operate. This vehicle handles differently than cars, trucks or off-road vehicles. A collision or rollover can occur quickly, even during routine maneuvers like turning, driving on hills or over obstacles if you fail to take proper precautions.

- Read this owner's manual that came with your vehicle.
- Understand all safety warnings, precautions and operating procedures before operating the vehicle.
- Keep this manual with the vehicle.
- Never operate this vehicle without proper instruction.
- Take an authorized training course. See the Safety Training section for more information.
- This vehicle is an **ADULT VEHICLE ONLY**. You **MUST** be at least age 16 and have a valid driver's license to operate this vehicle.
- Always use the cab nets (or doors) while riding in this vehicle. Always keep hands, feet and all other body parts inside the vehicle at all times.
- Always wear a helmet, eye protection, gloves, long-sleeve shirt, long pants and over-the-ankle boots.
- Never operate this vehicle under the influence of drugs or alcohol, as these conditions impair judgement and reduce the operator's ability to react.
- Complete the new operator driving procedures outlined this manual. Never allow a guest to operate this vehicle until the guest has completed the new operator driving procedures.
- Never permit a guest to operate this vehicle unless the guest has completed a safety training, reviewed the owner's manual and all safety labels.

The meaning of these signs:

WARNING

WARNING indicates a hazardous situation which, if not avoided, **COULD** result in death or serious injury.

CAUTION

CAUTION indicates a hazardous situation which, if not avoided, **COULD** result in minor to moderate injury.

NOTICE

NOTICE provides key information by clarifying instructions.

IMPORTANT

IMPORTANT provides key reminders during disassembly, assembly, and inspection of components.

The Prohibition Safety Sign indicates an action **NOT** to take in order to avoid a hazard.



The Mandatory Action Sign indicates an action that **NEEDS** to be taken to avoid a hazard.

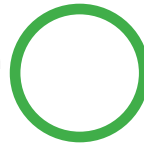



SAFETY INTRODUCTION

- WARNING LABELS.....1-2**
- SEVERE INJURY OR DEATH1-7**
- IMPORTANT SAFETY INFORMATION1-9**
 - Reading the manual.....1-9
 - Safe driving age.....1-9
 - Riding equipment.....1-9
 - Vehicle modification1-10
 - Passengers.....1-10
 - Contact exhaust.....1-10
 - Fuel safety1-11
 - Safety belt.....1-11
 - Cab door1-11
 - loading on the vehicle1-11
 - Passengers in the cargo compartment.....1-12
 - Operating on pavement.....1-12
 - Public road operation.....1-12
 - Overspeed1-12
 - Turning.....1-13
 - Jumping and Stunts.....1-13
 - Incorrect mountain climbing.....1-13
 - Down the hill1-13
 - Side road1-13

Failure to follow the warnings and safety precautions in this manual may result in serious injury or death. It can be dangerous to operate an on-road vehicle and is driven differently from other vehicles, such as motorcycles and automobiles. If proper precautions are not taken, a collision or rolled-over may occur during normal maneuvers such as turning, climbing, or overcoming obstacles. Understand all safety warnings, precautions and operating procedures before operating the vehicle. Bring this manual with you.

WARNING LABELS

Warning labels have been placed on the vehicle for your protection. Read and follow the instructions on the labels carefully. If any of the labels shown in this manual differ from the labels on your vehicle, always read and follow the instructions on the vehicle. If any label becomes illegible or comes off, contact Segway Powersports to obtain a replacement.

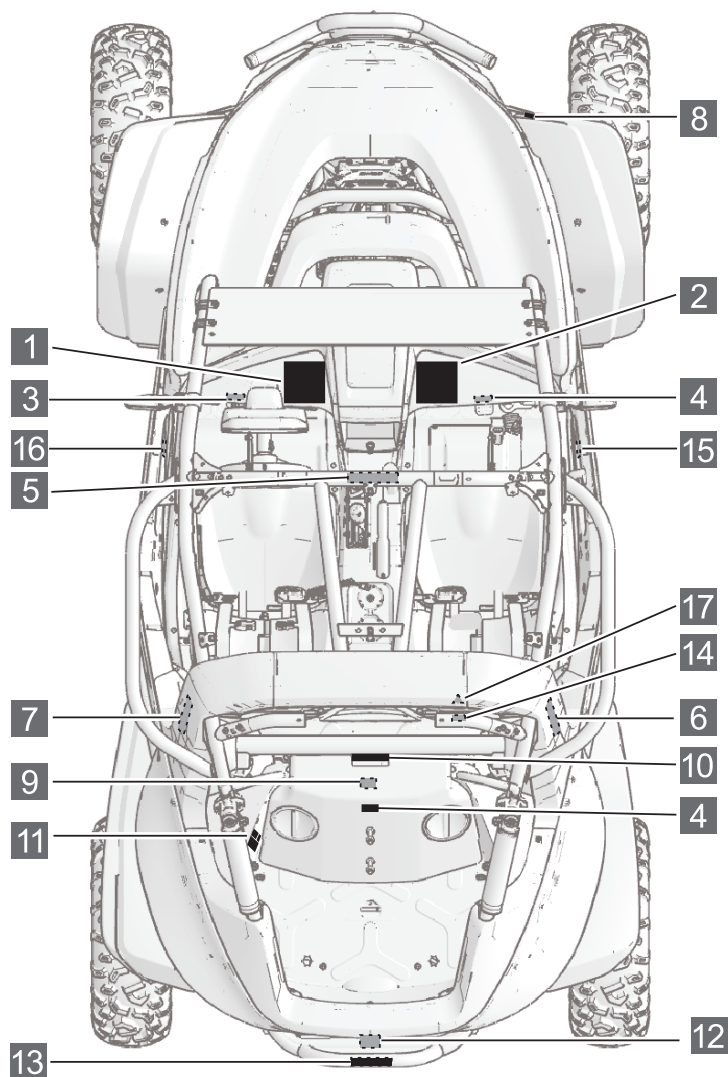

1

⚠ WARNING

Rollovers have caused severe injuries and death, even on flat, open areas. Be Sure Riders Pay Attention and Plan Ahead

If you think or feel the vehicle may tip or roll, reduce your risk of injury:

- Keep a firm grip on the steering wheel or handholds and brace yourself.
- Do not put any part of your body outside of the vehicle for any reason.

Drive Responsibly

Avoid loss of control and rollovers:

- Avoid abrupt maneuvers, sideways sliding, skidding or fishtailing, and never do donuts.
- Avoid hard acceleration when turning, even from a stop.
- Slow down before entering a turn.
- Plan for hills, rough terrain, ruts, and other changes in traction and terrain. Avoid paved surfaces.
- Avoid side hilling (riding across slopes).

Be Prepared

- Fasten seat belts and make sure nets or doors are securely latched in place.
- Wear an approved helmet and protective gear.
- Each rider must be able to sit with back against seat, feet flat on the floor, and hands on steering wheel or handholds. Stay completely inside the vehicle.

Require Proper Use of Your Vehicle

Do your part to prevent injuries:

- Do not allow careless or reckless driving.
- Make sure operators are 16 or older with a valid driver's license.
- Do not let people drive or ride after using alcohol or drugs.
- Do not allow operation on public roads (unless designated for off-highway vehicle access) – collisions with cars and trucks can occur.
- Do not exceed seating capacity: 1 passenger.

Never use on public roads

- On public roads – a collision can occur with another vehicle
- Never operate this vehicle on any public street, road or highway, even a dirt or gravel one.

Read and understand all safety labels, locate and read operator's manual.







S04L10006001

2

⚠ WARNING

PASSENGER

Improper Use of this Vehicle Can Cause Severe Injury or Death

Be Prepared

- Fasten seat belt and make sure net or door is securely latched in place.
- Wear an approved helmet and protective gear.
- You must be able to sit with back against seat, feet flat on the floor or on footrest, and hands on handholds. Stay completely inside the vehicle.

Be Sure Riders Pay Attention and Plan Ahead

If you think or feel the vehicle may tip or roll, reduce your risk of injury:

- Keep a firm grip on handholds and brace yourself.
- Do not put any part of your body outside of the vehicle for any reason.

PASSENGER QUALIFICATIONS AND RESPONSIBILITIES

- Do not ride after using drugs or alcohol.
- Ask the operator to slow down or stop if you feel uncomfortable when riding.



S05L10016001

3

⚠ WARNING

Turning the off road vehicle in 4WD-LOCK ("DIFF.LOCK") takes more effort. Operate at a slow speed and allow extra time and distance for maneuvers to avoid loss of control.

U09L10003001

4

⚠ WARNING

Storage compartment
Maximum load: 5 kg (11 lb)

S05L10022001

5

SEGWAY Technology Co., Ltd. certifies that this ROV complies with the American National Standard for Recreational Off-Highway Vehicles, ANSI / ROHVA 1 - 2016 Standard.

This roll over protective structure meets the performance requirements of ISO 3471: 2008 .

S05L10027001

6

⚠ WARNING

Be prepared in case of rollover
If the vehicle rolls over, any part of your body (such as arms, legs, or head) outside of the cockpit can be crushed by the cab frame or other parts of the vehicle. Fasten seat belt and make sure net and/or door is securely latched in place to help you avoid sticking out arms or legs.

NEVER Hold the cab frame while riding.

NEVER Try to stop a rollover using your arm or leg.

S05L10017001

7

⚠ WARNING

Be prepared in case of rollover
If the vehicle rolls over, any part of your body (such as arms, legs, or head) outside of the cockpit can be crushed by the cab frame or other parts of the vehicle. Fasten seat belt and make sure net and/or door is securely latched in place to help you avoid sticking out arms or legs.

NEVER Hold the cab frame while riding.

NEVER Try to stop a rollover using your arm or leg.

S05L10018001

8

U09L10029001

9

CAUTION

The air filter must be maintained in accordance with the requirements of the Segway «Owner's Manual» , otherwise it may seriously damage your engine.

U09L10032001

10

⚠ WARNING
Air Filter Inlet Grill. DO NOT COVER!





S05L10028001

11

⚠ WARNING



- NEVER carry passengers in cargo box.
- Passengers can be thrown off. This can cause serious injury or death.
- If total payload is greater than 573lbs (260Kg) , the vehicle must be operated in LOW range.
- NEVER place gasoline, flammable or dangerous liquids container on carrier. This can lead to an explosion.

- Reduce speed and allow greater distance for braking when carrying cargo.
- Overloading or carrying tall, off-center, or unsecured loads will increase your risk of losing control. Loads should be centered and carried as low as possible in box.
- For stability on rough or hilly terrain, reduce speed and cargo.

S04L10002001

⚠ WARNING

MAXIMUM CARGO BOX LOAD
198 lbs. (90 kg)
MAXIMUM WEIGHT CAPACITY Includes weight of operator passengers cargo and accessories
 < 573 lbs. (260 kg)
TIRE PRESSURE IN PSI (KPa)
 <ul style="list-style-type: none"> • Cold tire pressure: Front: 18 psi (124 kPa) Rear : 18 psi (124 kPa)

Read Operation and Maintenance Manual for more detailed loading information.

S04L10003001

12

⚠ WARNING
Improperly loading a trailer may cause loss of control. Evenly balance the load.

- Maximum unbraked towing mass 450 kg (992 lb)
- Maximum unbraked tongue mass 110 kg (242 lb)
- Maximum inertibraked towing mass 600 kg (1328 lb)
- Maximum inertibraked tongue mass 110 kg (242 lb)

S05L10029001

13



⚠ WARNING

NEVER Attach to the cab frame to pull a load. This can cause the vehicle to tip over. Use only the trailer hitch or recovery hook to pull a load.



S05L10030001

14

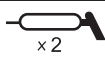

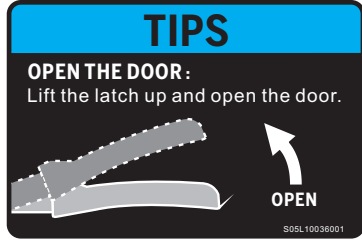

x 2

15

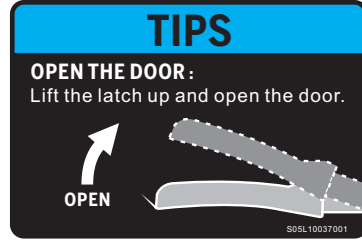

16



17



SEVERE INJURY OR DEATH

Can result if you do not follow these instructions:

- The minimum recommended driving age for this vehicle is 16 years.
- Never operate this vehicle without wearing an approved motorcycle helmet that fits properly.
- Wear eye protection (goggle or a face shield), gloves, over-the-ankle boots, long-sleeved shirt or jacket, and long pants.
- Never consume alcohol or drugs before or while operating this vehicle.
- Never attempt jumps or other stunts.
- Never operate at speeds too fast for your skills or the conditions. Always go at a speed that is proper for the terrain, visibility, operating conditions, and your experience.
- Always inspect your vehicle each time you use it to be sure it is in safe operating condition.
- Never operate on excessively rough, slippery, or loose terrain until you have learned and practiced the skills necessary to control the vehicle on such terrain. Always be cautious on these kinds of terrain.
- Always follow the inspection and maintenance procedures as well as the schedules described in this manual.
- Never operate on hills that are slippery or ones where you will not be able to see safely far enough ahead of you. Never go over the top of a hill at speed if you cannot see what is on other side.
- Always keep both hands, arms, feet, and legs inside the vehicle at all times during operation. Keep your feet on the floorboard. Never hold onto the enclosure, otherwise, you could be injured.
- Always keep both hands on the steering wheel when driving.
- Always go slowly and be careful when operating on unfamiliar terrain. Always be alert to changing terrain conditions when driving the vehicle.
- Never wrap your thumbs and fingers around the steering wheel. This is particularly important when driving in rough terrain. The front wheels will move right and left as they respond to the terrain, and this movement will be felt in the steering wheel. A sudden jolt could wrench the steering wheel around, and your thumbs or fingers could be injured if they are in the way of the steering wheel spokes.
- Never turn at excessive speed. Practice turning at slow speeds before attempting to turn at faster speeds. Do not attempt turns on steep inclines.
- Always follow proper procedures for going uphill. If you lose control and cannot continue up a hill, back down the hill with the engine in reverse gear. Use engine braking to help you go slowly. If necessary, use the brakes gradually to help you go slowly.
- Never operate the vehicle on hills that are too steep. Go straight up and down hills where possible.
-

- Never operate the vehicle in fast flowing water or water deeper than the floorboards on this model. Remember that wet brakes may have reduced stopping ability. Test your brakes after leaving water. If necessary, apply the brake several times to let friction dry out the linings.
- Always be sure there are no obstacles or people are behind you when you operate in reverse. When it is safe to proceed in reverse, go slowly.
- Always check terrain before going down hills. Go as slowly as possible. Never go down a hill at high speed.
- Always check for obstacles before operating in a new area.
- Do not brake abruptly when carrying loads in the cargo bed.
- Always use the size and type of tires specified in this manual.
- Always maintain proper tire pressure as described in this manual.
- Never exceed the stated cargo load capacity. Cargo should be as far forward in the bed as possible, and distributed evenly from side to side. Be sure cargo is secured so that it cannot move around during operation. Reduce your speed and follow the instructions in this manual for carrying cargo or pulling a trailer. Allow a greater distance for braking.
- Brake discs can be over heated after continuous braking. Allow brake disc to cool before servicing.
- Avoid the risks related to contact with hot surfaces, including residual risks such as filling oil or coolant in hot engines or transmissions.

IMPORTANT SAFETY INFORMATION

Reading the manual

Driving an SSV improperly increases the risk of accidents. The driver must know how to drive the vehicle correctly in different situations and on different terrain.

Before driving the vehicle, all drivers must complete the required driving safety training. Please ensure that each driver has read this manual and all product warning labels and has passed the safety training course. Otherwise, the vehicle will not be allowed to drive.



Safe driving age

The minimum recommended driving age for this vehicle is 16 years. Children under the age of 16 must not drive this vehicle. Never drive the vehicle without proper driving training. Training courses are required. Please ensure that each driver has read this manual and all product labels and has completed a safety training course.



Riding equipment

For your safety, we strongly recommend that you always wear an approved motorcycle, eye protection, boots, gloves, long pants, and a long-sleeved shirt or jacket whenever you ride.

Although complete protection is not possible, wearing proper gear can reduce the chance of injury when you ride.

Helmet

Wearing a helmet can prevent head injuries. At all times, you must wear a helmet that meets basic safety standards when driving. Both U. S. and Canadian qualified helmets bear a U. S. Department of Transportation label. ECE 22.05 marks are available in Europe, Asia and Oceania. The ECE mark consists of a circle around the letter E, followed by the approved area codes for different countries. The approval number and serial number are also displayed in the label.

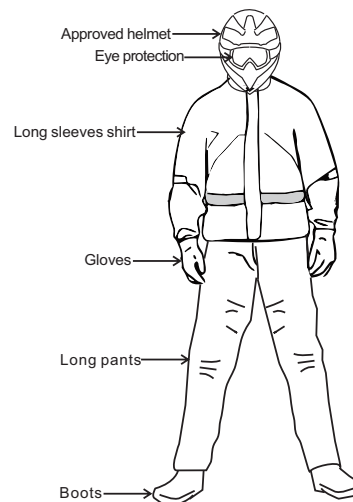

Sturdy off-road motorcycle boots to help protect your feet, ankles, and lower legs.
Off-road motorcycle gloves to help protect your hands.

It is recommended to wear riding pants with knee and hip pads, a riding jersey with padded elbows and, a chest/shoulder protector.

Driving SSV after drinking or taking drugs may adversely affect a driver's judgment, reaction time, balance, and feelings. Do not drink alcohol or take drugs before or during driving.

Using alcohol or drugs

Operating this vehicle after consuming alcohol or drugs could adversely affect operator judgment, reaction time, balance and perception.

Never consume alcohol or drugs before or while operating this vehicle.



Vehicle modification

We strongly recommend that consumers do not attempt to increase vehicle speed or use any equipment that increases the power of the vehicle. If any equipment is added to the vehicle, or if any modifications are made to the vehicle to increase the vehicle speed or power, the all-terrain vehicle warranty is terminated. The addition of certain parts may change the handling of the vehicle, including (but not limited to) mowers, sledges, tires, sprayers, or large luggage racks.



Passengers

Do not carry passengers unless you have operated the vehicle for at least two hours and have completed the new operator driving instructions outlined on page 3-2. Passengers must always sit in the passenger seat with the seat belt secured. Carrying more than one passenger in a two-seater vehicle affects the operator's ability to operate and operate control, increasing the risk of loss of control and accidents or rollovers. You cannot carry more than one passenger in a two-seater vehicle.



Contact exhaust

Engine exhaust is toxic and can cause loss of consciousness or death in a short time. Do not start or run a motor in a closed space. The engine exhaust of this product contains chemicals that cause cancer, birth defects or other reproductive damage, and you can only drive it outdoor or in a well-ventilated place



Fuel safety

Gasoline is very flammable under certain conditions

- You must be extremely careful when handling gasoline.
- When refueling, the engine must be shut off and must be done outdoors or in a well-ventilated area.
- No smoking, no open flames or sparks at or near the refueling or gasoline storage location.
- Do not overflow when refueling. Do not fill the tank to the filler neck.
- If gasoline gets on your skin or clothes, wash them with soap and water immediately and change clothes.

Safety belt

Driving without a safety belt increases the risk of rolling over, losing control, other accidents, or serious injury during a sudden stop. In such cases, seat belts reduce the severity of injuries and all drivers must wear them at all times.



Cab door

Driving in this vehicle without closing and locking the cab door increases the risk of serious injury or death in the event of an accident or a rollover. Always ensure that all cab doors are closed and locked while the vehicle is in operation. The cab door should not be used as a handrail. Always keep hands and feet in the car



Loading the vehicle

The weight of cargo and passengers affects the running and stability of the vehicle. For your own safety and the safety of others, think carefully about your own safety. Vehicle loading and how to operate the vehicle safely. Follow the instructions in this manual for loading, tire pressure, gear selection and speed.

- The maximum weight capacity of the vehicle is listed in the instruction section of this manual and on the vehicle label. As more passenger weight is added, the cargo weight may need to be reduced accordingly. Do not exceed the vehicle's weight capacity.
- Recommended tire pressures are listed in the instruction section of this manual and on the vehicle label.

Always follow the following guidelines:

conditions:	steps:
Passengers and/or cargo exceeding half of the maximum weight capacity	1. Driving slowly. 2. Confirm tire pressure. 3. Be very careful when operating.
Operate over rough terrain	
Climb over obstacles	
Climbing	
Traction	

Passengers in the cargo compartment

Loading passengers in the cargo compartment may cause the vehicle to fall or crash, which may result in passenger injury or more serious accidents. Never allow passengers to sit in the cargo compartment. Passengers must sit in the passenger seat with the seat belt secured.



Operating on pavement

The vehicle's tires are designed for off-road use, not for road use. Operating the vehicle on paved surfaces (including pavements, footpaths, car parks and lanes) may adversely affect the handling of the vehicle and may increase the risk of loss of control and an accident or rollover. Avoid operating vehicles on the road. If it is unavoidable, drive slowly to avoid swerving or stopping.

Public road operation

Operating this vehicle on public streets, highways or freeways may result in a collision with another

Do not operate this vehicle on any public street, road or highway, including dirt and gravel roads (unless designated for off-road use)

Overspeed

Running the vehicle at excessive speed increases the risk loss of control. Always operate at a speed suitable for the terrain, visibility and operating conditions, skills and experience.

Turning

Improper steering can result in loss of traction, loss of control, accidents, or cartwheels. Correct procedures must be followed as described in this manual. Avoid sharp turns. Don't turn when using a heavy throttle. Don't make a sudden turn. Practice turning at lower speeds before trying to turn faster.

Jumping and Stunts

Exhibition driving increases the risk of an accident or rollover. DO NOT do power slides, "donuts", jumps or other driving stunts. Avoid exhibition driving.

Incorrect mountain climbing

Improper climbing can lead to the danger of losing control of a vehicle or rolling over. Be extra careful when driving in the mountains. Appropriate procedures for climbing shall be followed in accordance with the methods described in this manual. See page 3-7.

Down the hill

Improper downhill maneuvers can result in the loss of control or rollovers. Follow the correct descent procedure as described in this manual. See page 3-7.

Side hill

Driving on hills is not recommended. Improper operation may cause the vehicle to lose control or turn over. Don't go over any hill unless absolutely necessary. If crossing a hillside is inevitable, follow the appropriate procedure described in this manual. See page 3-8.



VEHICLE DEVICE

VEHICLE ACTIVATION.....	2-1
Unlock Vehicle	2-1
App function.....	2-2
PARTS AND CONTROL	2-3
FRONT PANEL	2-4
Ignition lock/Start button	2-4
Switchs 1	2-4
Switchs 2	2-5
Switchs 3	2-6
Toggle switch for Two-wheel drive or Four-wheel drive	2-6
VEHICLE EQUIPMENT.....	2-7
The Power socket.....	2-7
Electronic Power Steering (EPS)	2-7
Seat	2-7
Seat adjustment.....	2-7
Seat removal/installation.....	2-8
Steering wheel adjustment	2-8
Four-point safety belt.....	2-9
Passenger seat belt.....	2-9
CAB DOOR.....	2-10
Refueling Cover	2-11
Passenger rail.....	2-11
Gearshift	2-12
Brake pedal and accelerator pedal.....	2-12
Parking brake.....	2-13
Roll-Overprotective Structures(ROPS).....	2-14
INSTRUMENT PANEL	2-15
Instrument indicator light/warning light	2-15
Indicator light/warning indication.....	2-16
Diagnostic displays code definitions	2-18

VEHICLE ACTIVATION

This vehicle is equipped with vehicle DTS system. DTS is used to communicate with background system and mobile APP, so as to obtain vehicle information and control vehicle with mobile APP. In order to make you quickly familiar with and use the system, please read the user's manual carefully, understand the relevant operation and use information.

NOTICE

The new vehicle must be activated on the APP for the first time if equipped with vehicle DTS, otherwise the vehicle will not start.

Please download the APP from the "APP STORE" in your mobile phone before you try to activate the SSV by the APP in the first time. Please search "**Segway powersports**" in the "APP STORE" in your mobile phone then download the APP as usual.

After the successful installation of the APP, the vehicle will be registered and activated. Firstly, find the VIN code on the vehicle and register on the APP. The registration procedure is as follows:

1. Power on the vehicle with the mechanical key.

Input or scan vehicle VIN code according to APP registration prompts, and step on the vehicle brake at the same time. Note: The vehicle identification code may not be scanned due to the influence of light. You can try to enter the VIN code manually. The vehicle VIN code is either on the vehicle frame (see Page 5-4) or on the vehicle nameplate (see Page 5-3).

2. Click the "CONFIRM" button to complete the vehicle binding operation.

3. Click "START" to start the vehicle.

Unlock Vehicle

There are three ways to unlock a vehicle:

1. Mechanical key (preferred).

2. APP remote unlock vehicle

APP Remote Unlock is based on 4G network. As long as the area covered by the network, you can use the remote unlock function in the APP to power the vehicle.

3. APP Bluetooth unlock vehicle

When both the vehicle and the mobile phone are on, within the effective connection distance of the Bluetooth signal, the vehicle Bluetooth module will automatically unlock the car after acquiring the mobile phone Bluetooth signal, and automatically lock the car when the mobile phone is far away.

NOTICE

After using the mechanical key to power down, the vehicle cannot be unlocked by induction to power up again. It needs to disconnect the reconnection and close the unlock to restart.

Mechanical key unlock is the optimal unlock method for vehicles. If you do not want to use the sensor unlock function, the sensor unlock setting can be turned off in the APP.

App Function

This app is a program designed for users who have the Segway vehicle.

Main features: driving control analysis, vehicle data analysis, etc.

Detail information pls see APP User Manual.

PARTS AND CONTROL

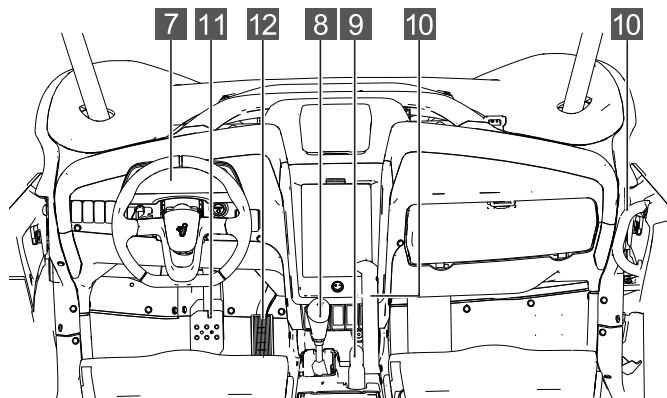
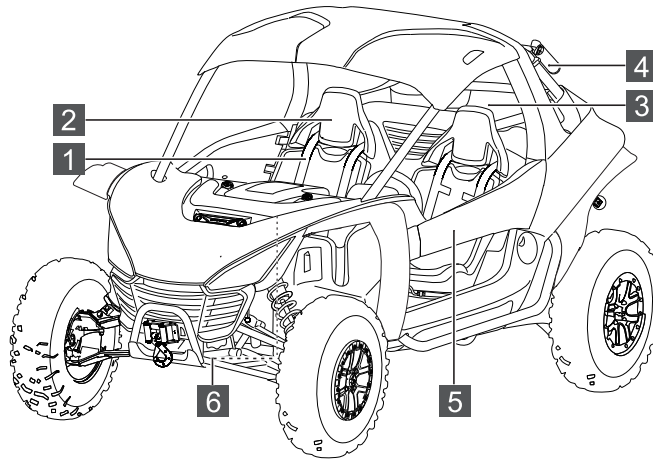

- | | | |
|-------------------------|-----------------------|-----------------------------|
| 1 Safety Belt | 2 Seat | 3 Packing |
| 4 Shock Absorber | 5 Cab Door | 6 Refueling |
| 7 IP | 8 Gearshift | 9 parking |
| 10 Armrest | 11 Brake Pedal | 12 Accelerator Pedal |

FRONT PANEL

Ignition Lock/Start Button

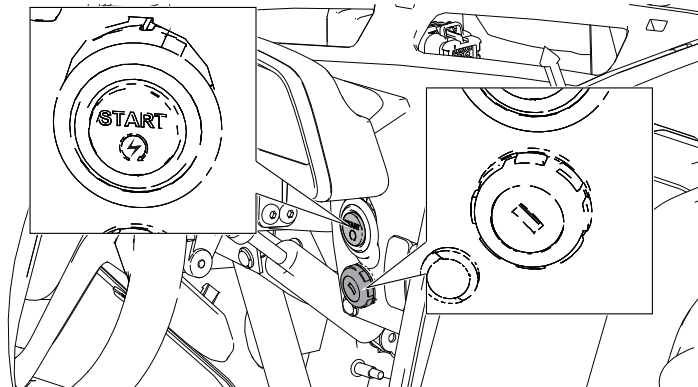

The ignition Lock

Turn the key to the position "ON" : the vehicle is powered on and can use the electrical components of the vehicle. Key to position "OFF" : the circuit of the vehicle is disconnected and the engine stops. When the switch is in the off position, the key can be taken out of the switch.

Start Button

Turn the key to the ignition lock switch "ON" and press the start button to start the vehicle.

Switches 1

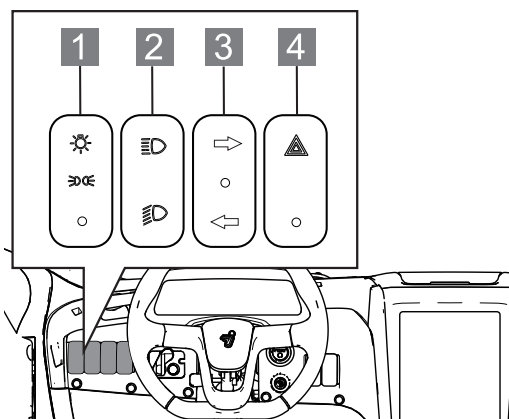

1 Position Light Switch

2 High Beam Switch

3 Turn Signal Switch

(if equipped)

4 Emergency Light Switch

(if equipped)

Highlight Switch

“ • ” Lamps off. “  ” Position light. “  ” lamps on.

High Beam Switch

 The ignition switch must be in the on position to operate the headlights. Press the switch to this position and place the headlight on the high beam. At this point, the corresponding figure on the meter will be bright.

 Press the switch to this position and place the headlight on the low beam.

Turn Signal Switch (if equipped)

 Press the switch to this position and the left turn signal is on. The corresponding icon on the meter is lit at this time.

 Press the switch to this position and the right turn signal is on. The corresponding icon on the meter is lit at this time.

- Turn off the turn signal in the middle.

Emergency Sight Switch(if equipped)

“  ”: Emergency light on.

“ • ”: Emergency light off.

Use this switch in case of vehicle emergency

- Temporary stop of vehicle
- Vehicle failure
- The vehicle encountered other emergencies

Switchs 2

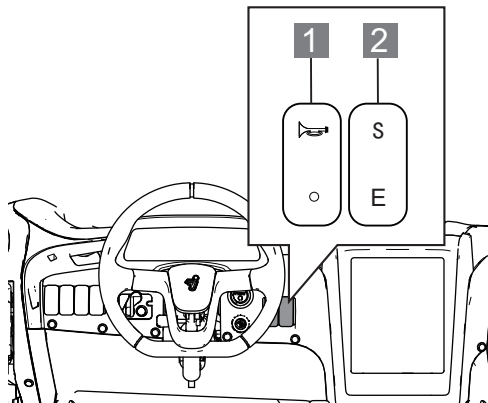

1 Horn Switch

2 Mode Switch

Horn Switch

“  ” horn on.

Mode Switch

“ S ” Sports model

“ E ” Economic model

Switchs 3

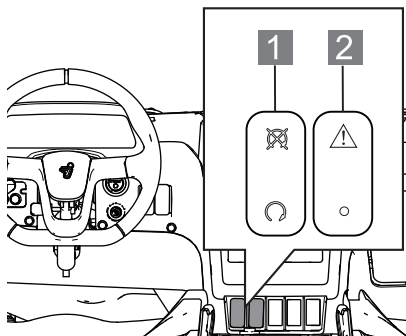

- 1 Emergency Stop Switch
- 2 Torque Switch

Emergency Stop Switch

- “⏻” Engine Start
- “⊗” Engine Stop torque switch
- “⚠️” Lift the max speed limit of the vehicle in 4WD-LOCK mode (18.6MPH (30KM/h)

Toggle Switch for Two-Wheel Drive or Four-Wheel Drive

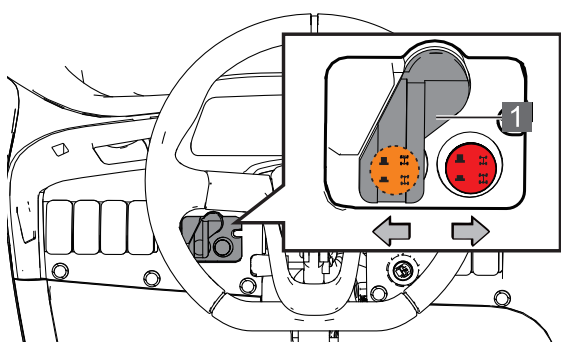

- 1 Handle Switch
- 2 x 4 patterns

When the two-four-wheel drive switch is in the two-wheel drive state, the whole vehicle is only driven by the rear wheel, and the front wheel has no power output. The meter shows the symbol “” for the second



drive. This mode is suitable for vehicles driving on flat roads.

4 x 4 patterns

When the two-four-wheel drive switch (4-wheel drive switch) is pressed, the symbol

“” of 4-wheel drive is displayed on the instrument. At this time, the instrument is in the state of 4-wheel drive, with power output of the front wheel and power output of the rear wheel. This mode is suitable for muddy conditions, mountainous conditions and other bad road conditions.

4x4 locking mode

When the two-four-wheel drive switch (4-wheel drive switch) is pressed, the four-wheel drive lock symbol “” is displayed on the instrument. At this time, the four-wheel drive lock is working in the state of 4-wheel drive lock. The front wheel has power output, the rear wheel has power output, and the left and right tires of the rear wheel output the same speed and power. The vehicle will in speed limitation and speed cannot more than 18 MPH (30km/h), this mode is suitable for vehicle in troubles. The speed limit can be released through the Override Switch “”.

VEHICLE EQUIPMENT

The Power Socket

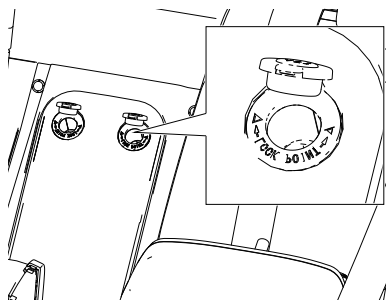

The vehicle is equipped with a 12V10A cigarette lighter socket and a 5V2A USB socket.

Output power: 12V/120W(MIX)

1: USB port

2: DC port

Electronic Power Steering (EPS)

When the engine starts, the Electronic Power Steering (EPS) if equipped begins to work. EPS keeps working no matter if the vehicle is running or idling. When the key turns to the connected position, the EPS warning indicator lights up briefly. Refer page 2-17.

After the engine stops, the EPS system will be turned off. If the EPS indicator light stays on after engine stop, it indicates that the EPS system has failed. Contact your Segway dealer to help you.

Seat

The vehicle is equipped with adjustable seats. The driver or passenger can adjust the seat according to the comfort level before starting the vehicle. The position of the seat should be adjusted so that the occupant's back can fit with the seat back, and the driver's foot can step on the brake pedal and accelerate pedal. Seat adjustment.

Seat Adjustment

There is a U-shaped adjustment lever at the front of the seat. Pull the U-shaped adjustment lever up with your hand to hold the forward or backward slide the seat and slide the seat to the desired position. Push down the U-bar and the seats will be locked in the new position. Loosen the U-bar. The seats will be locked in the new position.

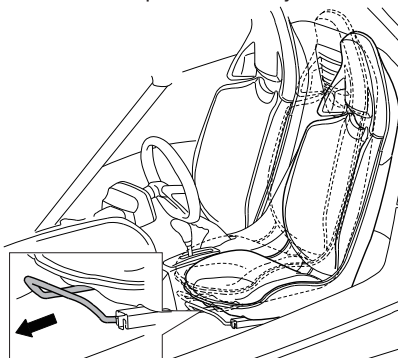

Seat Removal/Installation

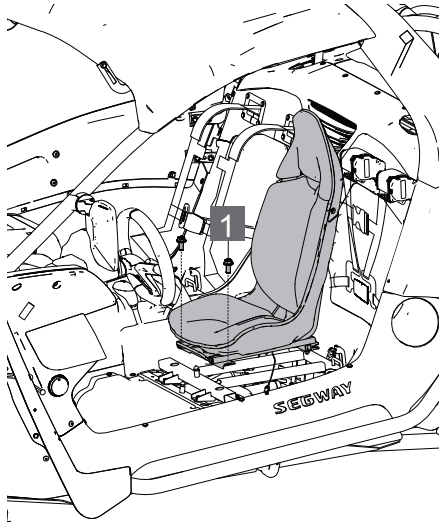

Removal

1 Bolts

1. First remove the seat belt from the seat
2. Remove the fixing bolts on both sides of the seat cushion assembly.
3. Gently pull the seat forward and pull out the wire harness under the seat.
4. Remove the seat from the vehicle.

Installation

1. Plug in the harness under the seat.
2. Insert the two nylon buffer blocks in the rear of the seat into the fixed hooks on the vehicle.
3. Install the fastening bolts on the left and right sides.

4. After installation, check whether the seat is installed in place to ensure the safety of drivers and passengers.

Steering Wheel Adjustment

The steering wheel can be tilted up or down to suit the driver's driving preference

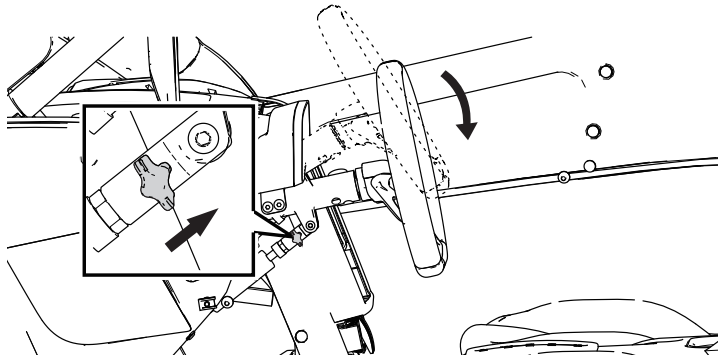

Adjust Angle of steering wheel up and down:

Do not loosen the adjustment lever of direction column after lifting it to the direction of steering wheel. With the other hand, adjust it to the proper position by moving it up or down to keep the steering wheel and release the adjusting lever.

After the steering wheel Angle adjustment, check whether the steering wheel is locked in place.

Four-Point Safety Belt

Fasten your seat belt as soon as you get in the vehicle seat belts can effectively protect the personal safety of drivers and passengers. When the vehicle encounters an accident, the seat belt can reduce the injury of the personnel on the vehicle. To wear a seat belt correctly, please follow the steps below:

Driver's seat belt

The driver's seat belt is a four-point retractable seat belt with a seat belt adjuster

1. Wear left and right seat belts on both shoulders

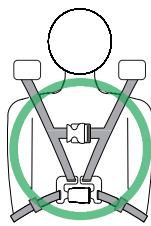

correct

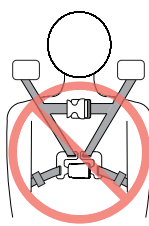

Too high

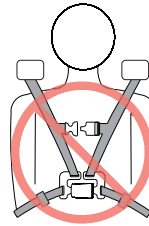

above unlocked

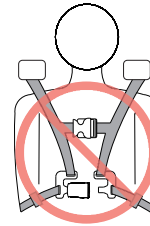

lower unlocked

2. Push the upper and lower latches into the upper and lower buckles, respectively, until it clicks
3. You can adjust the seat belt to keep it close to your body by using the retractor above the shoulder or by adjusting the pull to the lower belt on the lower side
4. Press the release lock on the upper and lower buckle to release the seat belt

Passenger Seat Belt

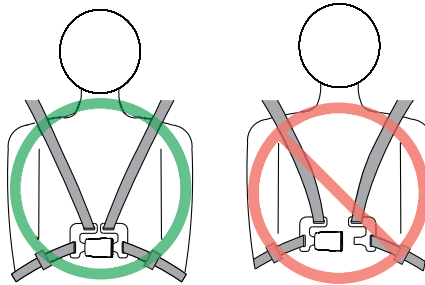

The passenger seat belt is a four-point belt. Adjust the length of the seat belt to keep it close to the body by adjusting the belt on both sides below to pull in or out of the safety belt.

⚠ CAUTION

Check that all seat belts are in working before each use.

Push the latch plate onto the buckle ring until it clicks. The latch plate must slide smoothly into the buckle.

Pull out each safety belt and check for any damage, including cutting, wear or stiffness. If any damage is found, or if the seat belt does not operate properly, contact a Segway dealer for replacement.

Clean dirt or debris on the seat belt and wipe the belt with mild soap and water. Do not use bleach, dyes or household detergents.

CAB DOOR

The vehicle is fitted with a cab door. Driving in this vehicle without closing and locking the cab door will increase the risk of serious injury or death in the event of an accident or rollover. When driving the car, make sure all cab doors are closed and locked.

Be sure to check doors and latches for wear and damage before each use. Replace any worn or damaged parts promptly and purchase new parts from your authorized Segway dealer.

Open/close the cab door

Lift the latch up and open the door. Pull the door inward, close the door after hearing the "click" sound, and check whether the door is locked after closing.

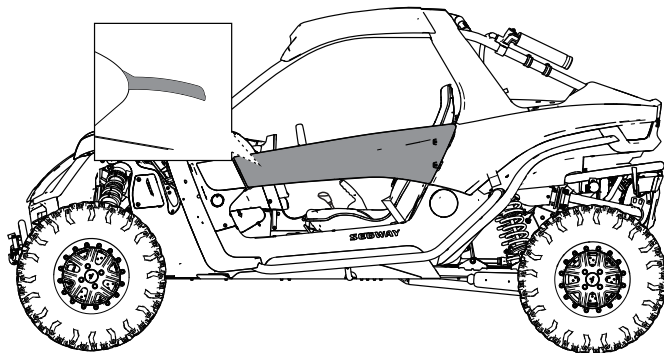

Refueling Cover

The fuel tank filling cap is located on the front right side of the vehicle.

WARNING

Always fill the fuel type specified by the vehicle. Do not smoke when filling the vehicle with fuel or it may ignite the fuel and cause a fire disaster. Do not touch other persons or objects with static electricity, which may cause static electricity to build up and ignite the fuel.

Do not let the fuel spill while filling.

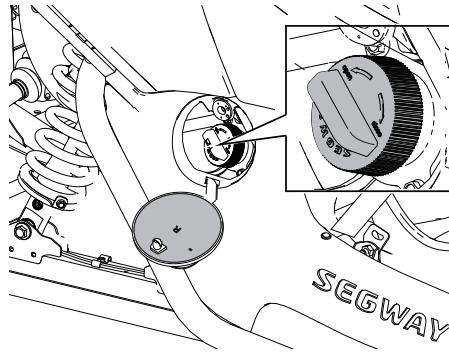

1. Hook the cover of the fuel tank with your finger and pull it back.
2. Unscrew the fuel tank cover in the direction of "OPEN" (see the direction sign on the fuel tank cover).
3. Refueling the vehicle (don't overfill it).
4. Tighten the fuel tank cap to the direction of "CLOSE" and CLOSE the fuel tank cap.
5. Place cover back.

Passenger rail

For the safety of passengers, please let passenger hold the passenger handrails before driving..

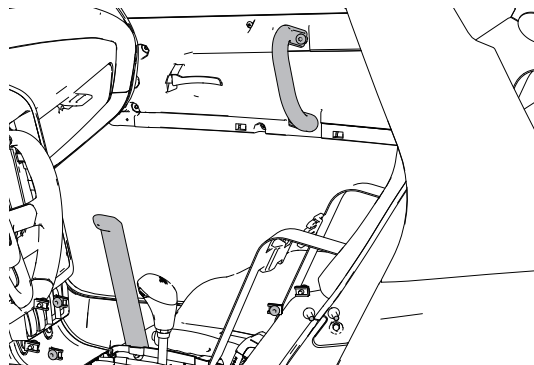

Gearshift

Different operation modes correspond to different gears. After selecting the gear, check the indicator light on the instrument panel to ensure that the gear has been switched to the desired position. See the table below for the tap position description:

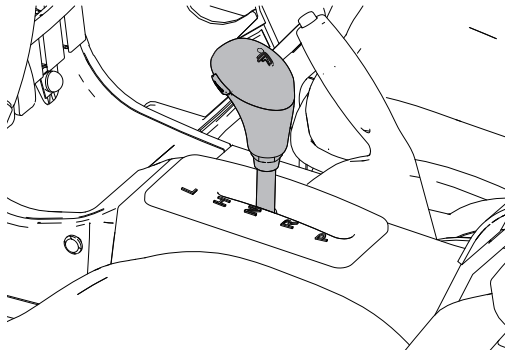

L Low speed

H High speed

N Neutral

R Reverse

P Parking

⚠ CAUTION

Shifting gears above engine idling or while the vehicle is moving can cause transmission damage. Before the driver leaves the vehicle, it must put the shifter in parking gear and lock the parking brake.

Brake pedal and accelerator pedal

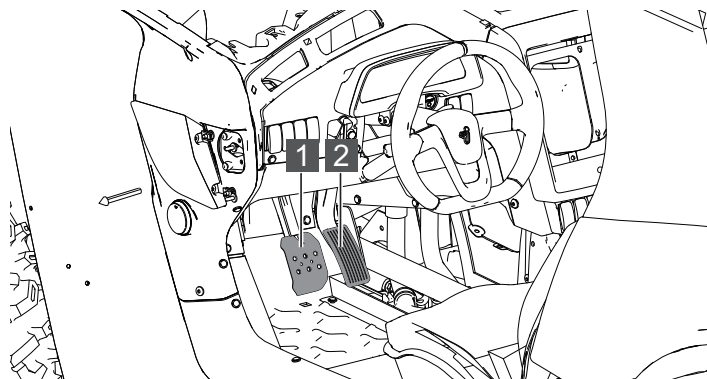

1 Brake Pedal

2 Gas Pedal

Brake pedal

Press the brake pedal **1** to slow down or stop. The brake is also used to start the engine. To slow down or stop, press down the brake pedal with your right foot. The brake pedal is spring-loaded and should return to position when not pressed.

Accelerator pedal

Push accelerator pedal **2** down to increase engine speed. To increase or maintain speed, press the accelerator pedal with your right foot. To slow down, release the accelerator pedal. The accelerator pedal is spring-loaded and should return to position when not pressed (idle speed).

When released, spring pressure returns the pedal to the rest position. Before starting the engine, always check that the accelerator pedal is back on track.

⚠ CAUTION

If both accelerator and brake pedals are applied, engine power may be limited.

Parking Brake

Whenever the driver leaves the vehicle, the parking brake handle must be pulled up to keep the vehicle in a reliable parking state.

Turn on parking brake: first step on the brake pedal with your foot to make the whole vehicle stand still, then press the button on the top of the parking brake handle with your thumb, and at the same time pull the parking brake handle up, you will hear a 'click' sound when the vehicle is reliably parked, and then leave the brake pedal with your right foot and the parking brake is activated.

Release the parking brake: Use your thumb to press the button on the top of the parking brake handle, and then lower the handle to make the handle fully return to the initial position, the parking brake is released, and the vehicle can be started at this time.

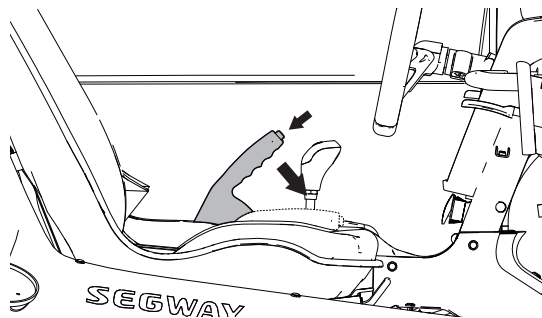

⚠ WARNING

When leaving the vehicle, always put the parking brake handle up to ensure that the vehicle is in the parking condition in order to prevent the vehicle from moving forward or backward and causing an accident.

Roll-Overprotective Structures (ROPS)

The rollover protection device (ROPS) of the vehicle meets (EU) No 1322/2014 Annex VIII rollover performance.

If there is any damage to the vehicle's rollover protection device, please contact Segway Powersports.

The dealer thoroughly inspects the ROPS or replaces it.

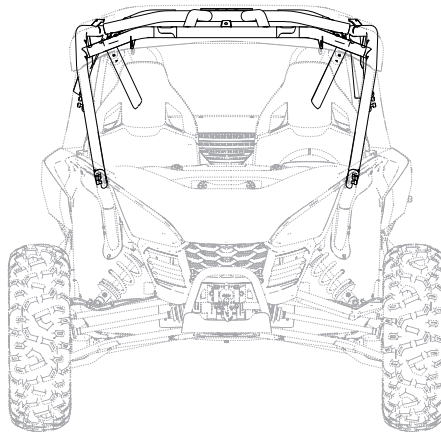

Always follow all safe operating practices outlined in this manual to avoid vehicle rollover.

WARNING

Vehicle rollover could cause severe injury or death. always avoid operating in a manner that could result in vehicle rollover.

INSTRUMENT PANEL

The instrument panel provides the operator with the vehicle information, and the driver should understand the meaning of the various indicators, warning lights and display content information on the instrument table, to understand the vehicle status.

NOTICE

The combination meter may be damaged by using a high pressure cleaner. Do not clean the instrument with alcohol or corrosive detergent. Corrosive liquid will corrode the surface of the instrument and cause damage to the instrument.

Instrument Indicator Light/Warning Light

Indicator lights and warning lights on the instrument indicate the status of the vehicle's systems. The figure below shows all the lights and warning lights.

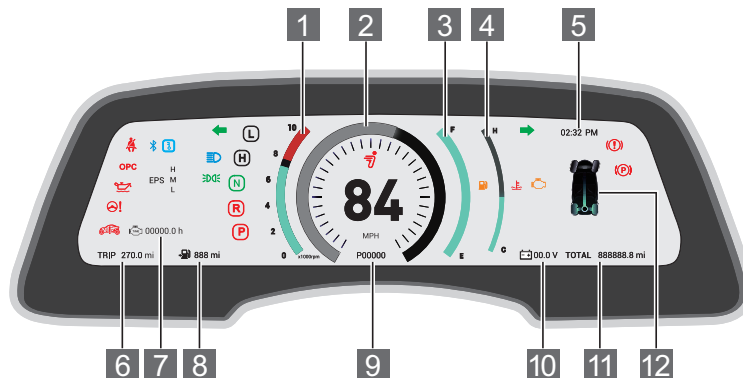

The ignition lock switch is placed " ON " mode, switch on the meter.

1 The Engine Tachometer Shows

the vehicle's real-time speed.

0→2→4→6→8→10(From low to high)

2 The Speedometer

shows the vehicle's real - time speed.

3 Fuel Quantity Indicator

E: Fuel empty F: Fuel full

Shows the fuel level in the fuel tank. Activate the low fuel warning when the last section is cleared. All segments including the fuel icon will flash and refuel

immediately.

4 Engine Water Temperature

thermometer shows the engine temperature.

C: engine water temperature low H: engine water temperature high

5 Time Display

After the vehicle is bound to the Segway Powersports APP, the time displayed on the dashboard will be automatically synchronized to the local time.

6 Subtotal Mileage

The dashboard does not have the function of clearing subtotal mileage, please clear the subtotal mileage through Segway Powersports APP.

7 Engine Running Time

Display engine running time

8 Dynamic Residual Mileage

Shows how many miles you can travel with the current amount of fuel left

9 Fault Code Display

In case of partial failure of the vehicle, the fault code is displayed in this area. See page 2-18 for detailed description of the fault code.

10 Battery Voltage

Display the current voltage of the vehicle battery

11 Total Mileage

Display the total mileage accumulated by the vehicle

12 Four-Wheel Drive Full Differential Lock



2 x 4 patterns

















4 x 4 patterns



4x4 locking mode

Indicator light/warning indication

Mark	name	description
	Safety Belt	This light reminds the operator to ensure that all riders wear helmets and seat belts before work. The driver seat belt is equipped with a seatbelt interlock. If the security belt is not fixed, the vehicle speed will be limited to 15 MPH (24 km/h).
	Off-Seat	This light is on after leaving the seat and the buzzer will beep when OPC is on.
	Oil Pressure	This light is on when oil pressure is too low.

	EPS system	Indicates a failure in EPS system (optional equipment, if equipped)
	Brake system	<ul style="list-style-type: none"> • Low brake fluid level • The braking system is faulty
	Parking Brake	This light is on after parking brake is applied.
	Engine Failure	This indicator appears if an EFI-related fault occurs. Do not operate the vehicle if this warning appears. Serious engine damage could result.
	Coolant Temperature	Indicator light showing excessive temperature of engine coolant. When it lights up and alarms, the engine should be stopped immediately and shut down. After cooling down to normal temperature, the engine should continue to run.
	Left Turn (if equipped)	This light is lit when the left turn signal is turned on.
	High Beam light	This lamp illuminates when the headlamp switch is set to high beam.
	Position light	The front light, tail light, license plate light and instrument panel light are on.
	Right turn (if equipped)	This light is lit when the right turn signal is turned on.
	Power icon on Bluetooth	The icon will light on when the APP Bluetooth power is used.
	Remote Power on	When starting the vehicle through the APP and this light will be on
EPS H M L	EPS mode	EPS mode was set in the APP and the preferred mode of the rider was selected: M -Normal mode, power normal H -Comfort mode, power light L -Motion mode, booster weight

Diagnostic displays code definitions

This area displays the code information of electrical components, circuits issues of the vehicle in case of failure or abnormality, please contact your dealer for any abnormalities or problems with this type of vehicle.

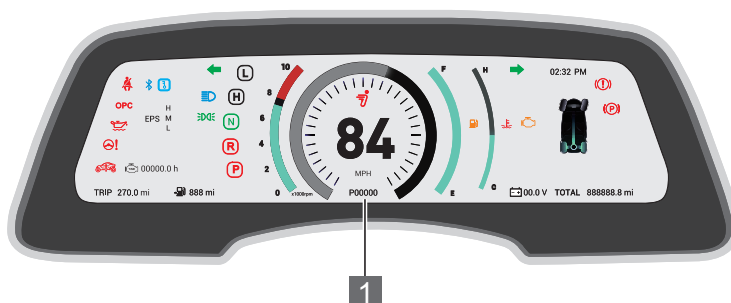

1 Fault Code Display Area

System	Fault Code	Failure Description
ECU	P0108 17	Manifold Absolute Pressure/Barometric Pressure Circuit High
	P0107 16	Manifold Absolute Pressure/Barometric Pressure Circuit Low
	P010C 17	Mass or Volume Air Flow "B" Circuit Low
	P010D 16	Mass or Volume Air Flow "B" Circuit High
	P0113 17	Intake Air Temperature Sensor 1 Circuit High
	P0112 16	Intake Air Temperature Sensor 1 Circuit Low
	P0118 17	Engine Coolant Temperature Sensor 1 Circuit High
	P0117 16	Engine Coolant Temperature Sensor 1 Circuit Low
	P0650 11	MIL Control Circuit Low
	P0650 13	MIL Control Circuit Open
	P0692 12	Fan 1 Control Circuit High
	P0691 11	Fan 1 Control Circuit Low
	P0480 13	Fan 1 Control Circuit
	P0629 12	Fuel Pump "A" Control Circuit High
	P0628 11	Fuel Pump "A" Control Circuit Low
	P0627 13	Fuel Pump "A" Control Circuit /Open
	P0459 12	Evaporative Emission System Purge Control Valve Circuit High
	P0458 11	Evaporative Emission System Purge Control Valve Circuit Low
	P0444 13	Evaporative Emission System Purge Control Valve Circuit Open
	P0412 12	Secondary Air Injection System Switching Valve "A" Circuit
	P0414 11	Secondary Air Injection System Switching Valve "A" Circuit Shorted
	P0413 13	Secondary Air Injection System Switching Valve "A" Circuit Open
	P0262 12	Cylinder 1 Injector Circuit High

ECU	P0414 11	Secondary Air Injection System Switching Valve "A" Circuit Shorted
	P0413 13	Secondary Air Injection System Switching Valve "A" Circuit Open
	P0262 12	Cylinder 1 Injector Circuit High
	P0261 11	Cylinder 1 Injector Circuit Low
	P0201 13	Injector Circuit/Open – Cylinder 1
	P0265 12	Cylinder 2 Injector Circuit High
	P0264 11	Cylinder 2 Injector Circuit Low
	P0202 13	Injector Circuit/Open – Cylinder 2
	P0563 17	System Voltage High
	P0562 16	System Voltage Low
	P0560 1C	System Voltage Not plausible
	P0501 29	Vehicle Speed Sensor "A" Range/Performance
	P0641 00	Sensor Reference Voltage "A" Circuit/Open
	P0651 00	Sensor Reference Voltage "B" Circuit/Open
	P0571 29	Brake Switch "A" Circuit
	P0571 1C	Brake Switch "A" Circuit
	P0123 17	Throttle/Pedal Position Sensor/Switch "A" Circuit High
	P0122 16	Throttle/Pedal Position Sensor/Switch "A" Circuit Low
	P0121 29	Throttle/Pedal Position Sensor/Switch "A" Circuit Range/Performance
	P0223 17	Throttle/Pedal Position Sensor/Switch "B" Circuit High
	P0222 16	Throttle/Pedal Position Sensor/Switch "B" Circuit Low
	P0221 29	Throttle/Pedal Position Sensor/Switch "B" Circuit Range/Performance
	P2106 12	Throttle Actuator Control System Forced Limited Power
	P2106 19	Throttle Actuator Control System Forced Limited Power
	P2106 92	Throttle Actuator Control System Forced Limited Power
	P2106 13	Throttle Actuator Control System Forced Limited Power
	P1568 00	Idle Speed Contr.Throttle Pos. mechanical Malfunction
	P1545 00	Throttle Pos.Contr. Malfunction
	P1545 22	Throttle Pos.Contr. Malfunction
	P1545 21	Throttle Pos.Contr. Malfunction
	P1565 00	Idle Speed Control Throttle Position lower limit not attained
	P2123 17	Throttle/Pedal Position Sensor/Switch "D" Circuit High
	P2122 16	Throttle/Pedal Position Sensor/Switch "D" Circuit Low
	P2138 29	Throttle/Pedal Position Sensor/Switch "D"/"E" Voltage Correlation
	P2128 17	Throttle/Pedal Position Sensor/Switch "E" Circuit High
	P2127 16	Throttle/Pedal Position Sensor/Switch "E" Circuit Low
	P0606 94	ECM/PCM Processor
	P0606 92	ECM/PCM Processor
	P2106 29	Throttle Actuator Control System Forced Limited Power
	P0606 64	ECM/PCM Processor

ECU	P0606 61	ECM/PCM Processor
	P0606 67	ECM/PCM Processor
	P0606 1C	ECM/PCM Processor
	P0606 55	ECM/PCM Processor
	P0606 00	ECM/PCM Processor
	P0606 62	ECM/PCM Processor
	P0606 96	function monitoring: fault of ECU ADC - Null Load Test Pulse
	P0606 97	function monitoring: fault of ECU ADC - test voltage
	P0606 47	function monitoring: fault of ECU monitoring modul error
	P0606 17	Reported OverVoltage of VDD5
	P0606 16	Reported UnderVoltage of VDD5
	P0606 49	Diagnostic fault check to report "WDA active"
	P0606 48	Diagnostic fault check to report "WDA active" due to errors in query-/response communication
	P0606 91	Diagnostic fault check to report "WDA active" due to overvoltage detection
	P0032 12	O2 Sensor Heater Control Circuit High Bank 1 Sensor 1
	P0031 11	O2 Sensor Heater Control Circuit Low Bank 1 Sensor 1
	P0030 13	O2 Sensor Heater Control Circuit Bank 1 Sensor 1
	P0132 17	O2 Sensor Circuit High Voltage Bank 1 Sensor 1
	P0131 16	O2 Sensor Circuit Low Voltage Bank 1 Sensor 1
	P0130 29	O2 Sensor Circuit Bank 1 Sensor 1
	P0134 13	O2 Sensor Circuit No Activity Detected Bank 1 Sensor 1
	P0052 12	O2 Sensor Heater Control Circuit High Bank 2 Sensor 1
	P0051 11	O2 Sensor Heater Control Circuit Low Bank 2 Sensor 1
	P0050 13	O2 Sensor Heater Control Circuit Bank 2 Sensor 2
	P0152 17	O2 Sensor Circuit High Voltage Bank 2 Sensor 1
	P0151 16	O2 Sensor Circuit Low Voltage Bank 2 Sensor 1
	P0150 29	O2 Sensor Circuit Bank 2 Sensor 1
	P0154 13	O2 Sensor Circuit No Activity Detected Bank 2 Sensor 1
	U0073 88	Control Module Communication Bus Off
	U0140 87	Lost Communication With Body Control Module
	U0121 87	Lost Communication With Anti-Lock Brake System (ABS) Control Module
	E0001	No midpoint of torque is written
	E0002	No end point of rotor angle is written
	E0003	Memory read write failure
	E0004	The main torque sensor is disconnected
	E0005	Abnormal output of main torque sensor
	E0006	The secondary torque sensor is disconnected

ECU	E0007	Abnormal output of secondary torque sensor
	E0008	The difference between main and secondary torques is too large
	E0009	The difference between the main torque before and after amplification is too large
	E0010	Electrical machinery unassisted
	E0011	Over electric current
	E0012	Abnormal busbar electric current
	E0013	CAN communication abnormal (Output abnormally)
	E0014	Rotor Angle jump
	E0015	The rotor Angle sensor is disconnected
	E0016	Power module failure
	E0017	Abnormal A phase electric current
	E0018	Abnormal C phase electric current
	E0019	Steering wheel Angle small gear abnormal
	E0020	Steering wheel Angle middle gear abnormal
	E0021	Steering wheel Angle jumps
	E0022	Steering wheel Angle value exceeds limit
E0023	The steering wheel Angle is not right	
E0024	Abnormal voltage at electrical machinery end	
T-BOX	T0001	GPS module failure
	T0002	4G module failure
	T0003	Bluetooth module failure
	T0004	Sensor failure
	T0005	Power CAN failure
	T0006	Body CAN failure
ABS	A0001	Left front wheel speed error signal
	A0002	Right front wheel speed error signal
	A0003	Left rear wheel speed error signal
	A0004	Right rear wheel speed error signal
	A0005	Voltage of ABS module is too high
	A0006	Voltage of ABS module is too low
	A0007	Vehicle speed single failure
	A0008	CAN single failure



BASIC DRIVING GUIDE	3-1
Trail Etiquette	3-1
Know your riding area/tread lightly	3-1
Vehicle Run-in period	3-1
Brake system run-in	3-2
Clutch/belt	3-2
New operator driving procedures	3-2
Driving With Passengers	3-3
Starting the vehicle	3-3
Park the vehicle	3-3
Braking	3-4
Parking the vehicle	3-4
Driving on slippery surfaces	3-4
Driving through water	3-5
Driving in reverse	3-6
Driving over obstacles	3-6
Driving uphill	3-6
Driving downhill	3-7
Driving on a sidehill (sidehilling)	3-8
Parking on an incline	3-8
Break-in Guidelines	3-9
PRE-RIDE INSPECTION	3-10
Inspection Items	3-10
HAULING CARGO	3-11
Maximum loading capacity	3-12
Loading guidelines	3-12
Trailer	3-12
WINCH OPERATION	3-13
Winch Operation	3-16

This section provides basic operating instructions, including how to start and stop the vehicle, driving skills and precautions when driving on different roadways.

Even if you've ridden other SSVs, you must take time to familiarize yourself with how the vehicle operates. Practice in flat and wide areas until you are familiar with this all-terrain vehicle.

 **WARNING**

Failure to inspect and verify that the vehicle is in safe operating condition before operating increases the risk of an accident. Always perform the Pre-Ride Inspection outlined in the Operation chapter before each use of your vehicle to make sure it's in safe operating condition. Always follow the inspection and maintenance procedures and schedules described in this owner's manual. See the Periodic Maintenance section of the Maintenance chapter.

BASIC DRIVING GUIDE

Trail Etiquette

Always practice good etiquette when riding. Allow a safe distance between your vehicle and other vehicles operating in the same area. Communicate to oncoming operators by signaling the number of vehicles in your group. When stopping, move your vehicle to the edge of the trail as far as possible to allow others to pass safely.

Know your riding area/tread lightly

Familiarize yourself with all laws and regulations concerning the operation of this vehicle in your area. Respect the environment in which you ride your vehicle.

Find out where the designated riding areas are by contacting your dealer, a local riding club, or local officials. Help keep our trails open for recreational vehicle use.

Vehicle Run-in period

Your vehicle's run-in-period is the first 25 hours of operation or the riding mileage which used first two full tanks of fuel. Careful handling of new engine and drive components will improve the performance and service life of these components. Follow these steps carefully.

Brake System run-in

In order to achieve the best braking performance, the brake must be No less than 124mi(200Km) run-in when use.

Heavy or excessive braking when using the new braking system may damage the brake pad and disc.

Clutch/Belt

Proper run-in of the clutch and driving belt will ensure longer service life and better performance. Run the run-in clutch and belt at low speeds for the recommended run-in time, only pulling light loads. Avoid violent acceleration and high speed running during run-in. If the belt is broken, be sure to clean up the Intake and outlet pipeline and any debris from the clutch and engine compartment during belt replacement

New Operator Driving Procedures

1. Before operating the vehicle, read and understand the owner's manual and all warning and instruction labels.
2. Perform a pre-drive check.
3. Do not carry goods during this period.
4. Do not carry passengers until you have driven the vehicle for at least two hours.
5. Choose a suitable and open area to familiarize yourself with the operation of the vehicle.
6. Safety helmets, eye protection, gloves, long-sleeved shirts, long pants, anti-ankle boots and safety belts must be worn at all times.
7. When driving this vehicle, make sure that all cab doors are closed and locked.
8. Sit in the driver's seat, fasten your seat belt, and put the transmission in "P" gear.
9. Release the parking brake.
10. Start the engine.
11. Put the transmission in low gear.
12. Check your surroundings and determine your driving route.
13. Hold the steering wheel with both hands, slowly release the brake, depress the accelerator with your right foot, and start driving.
14. Drive slowly first, and practice starting, stopping, turning, maneuvering, using the accelerator, brakes, and reversing on a flat ground. When learning how the vehicle operates, practice turning left and right at a slow speed.
15. When you make a turn proficiently and start running at a faster speed, please follow the following precautions:
 - Avoid sharp turns.
 - Do not steer when using high throttle.
 - Don't steering suddenly.

- The operating speed is suitable for your skills, conditions and terrain.
- Do not jump the vehicle or perform any other driving stunts.

Driving with Passengers

1. Complete the new operator driver outlined on page 3-2.
2. Perform pre-drive inspection.
3. Do not carry more than one passenger in a 2-seater vehicle.
4. All riders must be able to sit with their backs on the seat, with their feet flat on the floor, and their hands on the steering wheel (if driving) or on the passenger armrest/grab bar.
5. The driver and all passengers must wear helmets, eye protection, gloves, long-sleeved shirts, trousers, ankle boots and safety belts.
6. When driving this vehicle, make sure that all cab doors are closed and locked.
7. Passengers can only sit in the passenger seat.
8. Slow down. Always travel at a speed appropriate for your skills, your passengers' skills and operating conditions. Avoid unexpected or aggressive maneuvers that could cause discomfort or injury to a passenger.
9. Vehicle handling may change with passengers and/or cargo on board. Allow more time and distance for braking.

Starting the Vehicle

1. Press the brake pedal and do not release it.
2. Turn the ignition switch to the "ON" position
3. When the engine start button is on, press the start button to start the vehicle engine

Before starting the vehicle, wear riding equipment, make sure the doors are closed, and both the driver and passengers must wear seat belts.

Park the Vehicle

1. Press the brake pedal and put the shifter in "P"
2. Turn the key to the " OFF " position (page 2-4) and the key can be taken out of the switch.
3. Put the parking brake handle up(page 2-13)

Braking

1. Release the throttle pedal completely.

NOTICE

When the throttle pedal is released completely and engine speed slows to near idle, the vehicle has no engine braking.

2. Press on the brake pedal evenly and firmly.
3. Practice starting and stopping (using the brakes) until you're familiar with the controls.

Parking the vehicle

1. Stop the vehicle on a level surface. When parking inside a garage or other structure, be sure that the structure is well ventilated and that the vehicle is not close to any source of flame or sparks, including any appliance with pilot lights.
2. Place the transmission in PARK.
3. Stop the engine.
4. Slowly release the brake pedal and make sure the transmission is in PARK before exiting the vehicle.
5. Remove the ignition key to prevent unauthorized use.

Driving on Slippery Surfaces

Whenever riding on slippery surfaces such as wet trails or loose gravel, or during freezing weather, follow these precautions:

1. Do not operate on excessively rough, slippery or loose terrain.
2. Slow down when entering slippery areas.
3. Engage 4X4 before wheels begin to lose traction.

NOTICE

Severe damage to drive train may occur if the 4X4 is engaged while the wheels are spinning. Allow the rear wheels to stop spinning before engaging 4X4, or engage 4X4 before wheels begin to lose traction.

4. Maintain a high level of alertness, reading the trail and avoiding quick, sharp turns, which can cause skids.
5. Correct a skid by turning the steering wheel in the direction of the skid. Never apply the brakes during a skid.

Driving through water

Your vehicle can operate through water with a maximum 40cm. Follow these precautions when operating through water:

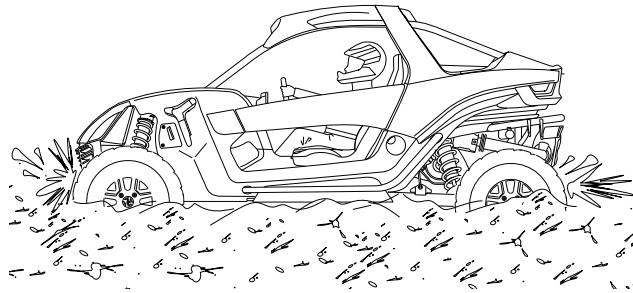

⚠ CAUTION

Major engine damage can result if the vehicle is not thoroughly inspected after operating in water. Perform the services outlined in the Periodic Maintenance Chart. The following areas need special attention: engine oil, transmission oil, demand drive fluid and all grease fittings. If the vehicle tips or overturns in water, or if the engine stops during or after operating in water, service is required before starting the engine. Your dealer can provide this service. If it's impossible to bring the vehicle in before starting the engine, perform the service outlined in the Vehicle Immersion section of this manual, and take the vehicle in for service at the first opportunity.

1. Determine water depths and current before entering water.
2. Choose a crossing where both banks have gradual inclines.
3. Avoid operating through deep or fast-flowing water.
4. After leaving water, test the brakes. Apply them lightly several times while driving slowly. The friction will help dry out the pads. If it's unavoidable to enter water deeper than the footrest level:
 - Proceed slowly. Avoid rocks and obstacles.
 - Balance your weight carefully. Avoid sudden movements.
 - Maintain a steady rate of speed. Do not make sudden turns or stops. Do not make sudden throttle changes.

Driving in reverse

Follow these precautions when operating in reverse:

1. Always check for obstacles or people behind the vehicle.
2. Apply the throttle lightly. Never open the throttle suddenly.
3. Back slowly.
4. Apply the brakes lightly for stopping.
5. Avoid making sharp turns.

Driving over obstacles

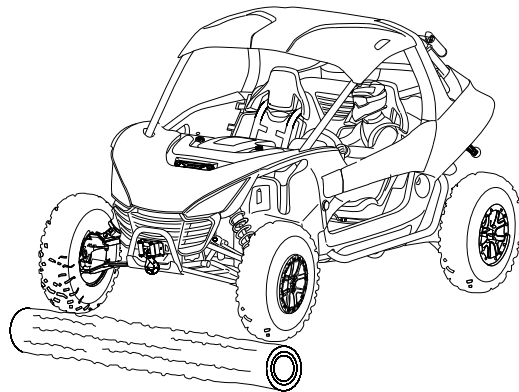

Follow these precautions when operating over obstacles:

1. Before operating in a new area, check for obstacles.
2. Watch out for bumps, potholes and other obstacles in the terrain.
3. When you approach any obstacle, reduce your speed and be prepared to stop.
4. Never try to ride over large obstacles, such as large rocks or fallen logs.
5. Always have a passenger dismount before operating over an obstacle that could cause a fall from the vehicle or vehicle tip over.

Driving uphill

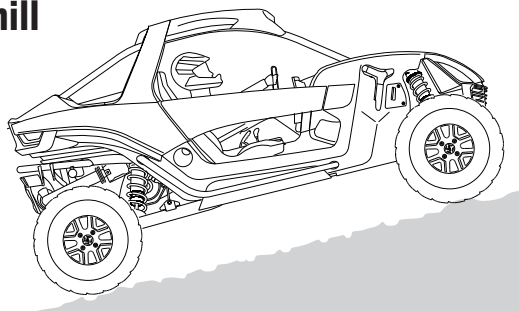

Braking and handling are greatly affected when operating in hilly terrain. Improper procedure could cause loss of control or rollover. Whenever traveling uphill, follow these precautions:

1. Always move the 4X4 switch to 4X4WD (if equipped) before ascending or descending a hill.
2. Drive straight uphill.
3. Proceed at a steady rate of speed and throttle opening. Never open the throttle suddenly.
4. Avoid unnecessary changes in speed or direction.
5. Never to over the crest of a hill at high speed. An obstacle, a sharp drop, or another vehicle or person could be on the other side of the hill.
6. If the vehicle stalls while climbing a hill, apply the brakes. Place the transmission in reverse and slowly allow the vehicle to roll straight downhill while applying light brake pressure to control speed.

Driving downhill

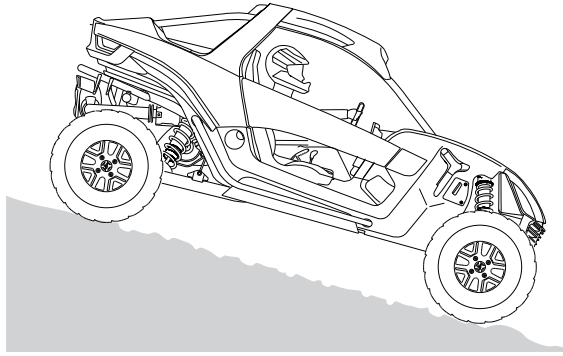

When driving downhill, follow these precautions:

1. Always move the 4X4 switch to 4X4WD (if equipped) before ascending or descending a hill.
2. Always check the terrain carefully before descending a hill.
3. Always descend a hill with the transmission in forward gear. Do not descend a hill with the transmission in neutral.
4. Slow down. Never travel down a hill at high speed.
5. Drive straight downhill. Avoid traveling down a hill at an angle, which would cause the vehicle to lean sharply to one side.
6. Apply the brakes slightly to aid in slowing. Applying the brakes too firmly may cause the rear wheels to lock, which could result in loss of control.

Driving on a sidehill (sidehilling)

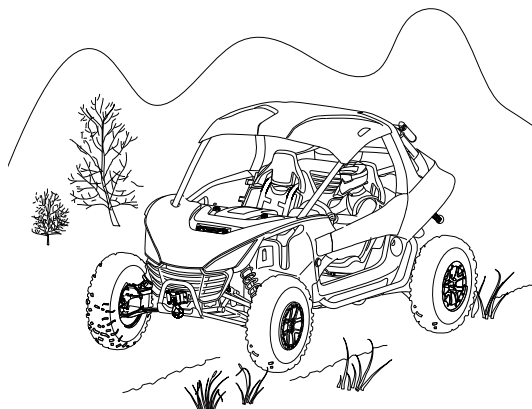

Driving on a sidehill is not recommended. Improper procedure could cause loss of control or overturn. Avoid crossing the side of any hill unless absolutely necessary.

If crossing a sidehill is unavoidable, follow these precautions:

1. Slow down.
2. Avoid crossing the side of a steep hill.
3. If the vehicle begins to roll over, or if it feels as if it may roll over, immediately turn downhill.
4. Avoid obstacles and changes in terrain that may lower or raise one side of the vehicle or cause the vehicle to slide.
5. If the vehicle begins to slide downhill, immediately turn downhill to stop the slide, or stop the vehicle and maneuver slowly and carefully until the vehicle can be driven straight downhill.

Parking on an incline

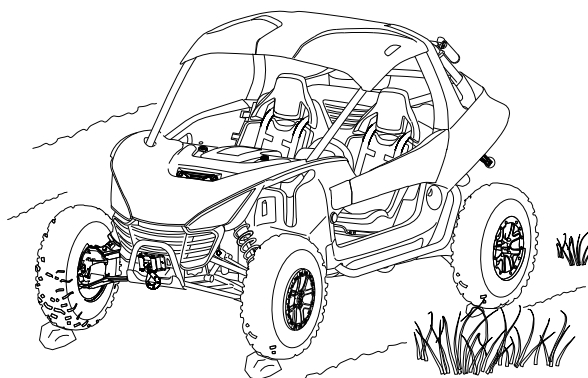

Avoid parking on an incline if possible. If it's unavoidable, follow these precautions:

1. Stop the engine.
2. Place the transmission in PARK.
3. Lock the parking brake.
4. Always block the rear wheels on the downhill side.

Break-in Guidelines

The engine break-in period is the first 25 hours of operation or the riding mileage which used first two full tanks of fuel.

- Avoid full throttle operation.
- Avoid pressing the accelerator pedal past $\frac{3}{4}$ down.
- Avoid continuous acceleration.

The brake needs a 124mi(200Km) run-in period.

New brakes will not operate at their maximum efficiency until the break-in period is over. Brake performance may be compromised if not followed.

NOTICE

During this period, avoid full-throttle running, rapid acceleration, and constant rpm operation.

PRE-RIDE INSPECTION

Perform a pre-ride inspection before each ride to detect any potentials problem that could occur during operation. The pre-ride inspection will help you monitor component wear and deterioration before they become a problem.

Correct any problems that you discover to reduce the risk of a breakdown or accident.

Inspection Items

Item	Note	Page
Brake system	Ensure proper operation	4-17
Brake fluid	Ensure appropriate level	4-18
Front suspension	Check and lubricate if necessary	4-24
Rear suspension	Check and lubricate if necessary	4-24
Tire	Check status and pressure	4-19
Wheel/fastener	Check to ensure the tightness of fasteners	4-20
Nut, bolt, fastener	Check to make sure it's tight	—
Fuel	Ensure appropriate level	—
Engine oil	Ensure appropriate level	4-8
Coolant level	Ensure appropriate level	4-14
Coolant pipe	Check leakage	—
Throttle	Ensure proper operation	—
Indicator/switch	Ensure proper operation	2-3
Air intake prefilter	Check ,clean	4-25
Front headlight	Check operation	2-3
Brake light/taillight	Check operation	2-3
Seat belt	Check the length of the seat belt for damage and check whether the latch is in normal operation	2-9
Cab door	Inspect doors and latches for wear or damage	2-10

HAULING CARGO

WARNING

Overloading the vehicle or carrying cargo improperly can alter vehicle handling and may cause loss of control or braking instability. Always follow these precautions when hauling cargo:

Never exceed the stated load capacity for this vehicle.

Reduce speed and allow greater distances for braking when hauling cargo.

Never exceed the maximum weight capacity of the vehicle.
When

determining the weight you are adding to the vehicle, include the weight of the operator, passenger(s), accessories and loads in the rack or box. The combined weight of these items must not exceed the maximum weight capacity.

Always load the cargo box with the load as far forward and as low as possible.

When operating over rough or hilly terrain, reduce speed and cargo to maintain stable driving conditions.

Always operate the vehicle with extreme care when hauling cargo. Slow down and drive in the lowest gear available.

SECURE ALL LOADS BEFORE OPERATING. Unsecured loads can create unstable operating conditions, which could result in loss of control of the vehicle.

OPERATE ONLY WITH STABLE AND SAFELY ARRANGED LOADS. When handling off-centered loads that cannot be centered, securely fasten the load and operate with extra caution.

HEAVY LOADS CAN CAUSE BRAKING AND CONTROL PROBLEMS. Use extreme caution when applying brakes with a loaded vehicle. Avoid terrain or situations that may require backing downhill.

USE EXTREME CAUTION when operating with loads that extend over the rack sides. Stability and maneuverability may be adversely affected, causing a rollover.

DO NOT TRAVEL FASTER THAN THE RECOMMENDED SPEED. Vehicle should never exceed 10 MPH (16 km/h) while cornering or while ascending or descending on a hill.

Carrying a passenger(s) in the cargo box could result in a fall from the vehicle or contact with moving components. Never allow a passenger to ride in the cargo box. A passenger must always be seated in a passenger seat with seat belt secured.

Maximum loading capacity

Don't over the maximum loading capacity.

Vehicle Model		SGW1000F
Maximum weight capacity		573 lbs. (260 kg)
Maximum cargo load		198 lbs. (90 kg)
Maximum traction	Horizontal	1433 lbs. (650 kg)
	Vertical	242 lbs. (110 kg)

Loading guidelines

When transporting cargos, please follow these instructions:

1. Do not exceed the weight specified in the warning label and specifications in this manual.
2. Never allow passengers to sit in the container.
3. Make sure all cargo is secured before riding.
4. Avoid riding on steep slopes when carrying cargo or pulling a trailer.
5. Use low-speed gear when hauling heavy cargo.
6. When handling cargo, operate the vehicle with caution.

Trailer

The towing device is a detachable part. It can be removed from the Vehicle if you are not using a trailer. If you need to tow a load, remember that the towing weight does not include the item being towed.

- The total load (weight on the operator, accessories, cargo and trailer) shall not exceed the maximum capacity of the vehicle.

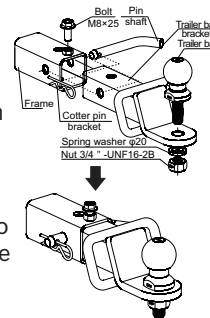

Where a designated attachment point is provided on the towbar:

Either:

Pass the cable through the attachment point and clip it back on itself.

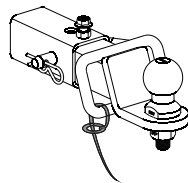

Or:

Attach the clip directly to the designated point. This option must be permitted by the trailer manufacturer since the clip may not be sufficiently strong for use in this way.

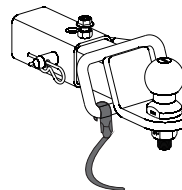

WINCH OPERATION

If your vehicle is equipped with a winch, please read this manual before use to understand and be familiar with the relevant safety precautions and operating instructions.

WARNING

The user must read and understand the operating instructions and warnings of this operation owner's manual. If the instructions or warnings are not followed, serious property damage or personal injury may occur.

- It is strictly prohibited for people under the age of 16 years old to use this equipment.
- Before operation or during use, pay attention to the safety and environmental conditions within the operating range of the winch.
- Do not overload. Ensure that all equipment used meets the maximum rope pull force rating. We recommend using an optional pulley block, double rope using a pulley block double rope will help reduce the load on the winch, rope and battery. When using a double rope, the rated value of the pulley block should be two times the rope pull of the winch rating.
- Under heavy loads, do not operate the winch for long periods of time. Electric winches are only designed for intermittent use and, should not be used under constant load. Do not pull for more than one minute. If the winch motor feels very hot, stop the winch and let it cool down for a few minutes.
- The rope end cannot bear the full load when fully extended, the rope must rotate around the drum at least 5 times.
- Avoid pulling from extreme angles, as this will cause the rope to be rolled on one end of the barrel and may damage the rope or winch.
- Note that the rope-drawing capacity of the winch is the maximum rope-drawing capacity of the first layer, do not operate the winch with overload capacity past this amount of rope.
- Never hook the rope back to itself, otherwise the rope will become damaged. Use trunk protection protector.
- Before operation, make sure that the winch is firmly installed on the vehicle or bracket.
- Before moving heavy objects, check the rope to prevent kinks and uneven wire layers. The rope slack must be properly tightened under a weight of about 220 lbs. (100Kg).
- When pulling the load, be sure to place a protective layer on the wire rope near the hook end. This will prevent the possibility of breaking the rope and help prevent serious injuries and damage.

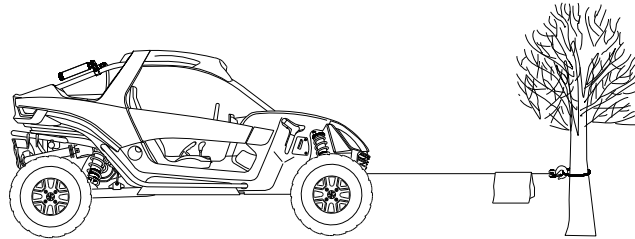

- Do not move the winch to assist in hauling heavy objects, it is easy to overload the winch and cause damage to the rope.
- Pay attention to the dangerous area. Stay away from the danger area during winch operation. The dangerous area is the area that contains the winch drum, fairlead, rope, pulley block, hook and motor.
- When the winch is under load, do not approach or cross the rope.
- When using the winch to move the load, place the vehicles transmission in neutral and apply the brake of the vehicle and place wedges under each wheel. When the hoist is working, the vehicle engine should be operated to charge the battery. Never use the winch with insufficient voltage.
- Never disconnect the power supply when there is a load on the winch.
- After the operation, release the load immediately and do not tighten the rope.
- Always stay away from ropes, hooks and winches when in operation or under load.
- Check winches, ropes, hooks, and broken strands of worn rope regularly. When handling the rope, please wear thick leather gloves. Do not let the rope slip over your hands. Check the rope before use.
- Crushed, pinched, worn or kinked areas seriously reduce the carrying capacity. A damaged rope should be replaced. It must be re-wound under a load of about 100 pounds.
- The clutch should be disconnected first, and then the rope should be pulled by the hook of the protective lever. Do not pull the rope directly through the hook with your fingers.
- Maintain the specified tension so that the rope can be wound on the reel and re-rolled after the operation tight.
- Do not operate the winch under the influence of alcohol or drugs. Be cautious during operation. If there is a problem, you should cut off the battery immediately and check it carefully.
- Wear goggles, insulating overalls, non-slip shoes, work caps, thick leather gloves. Place long hair tightly under a work cap and remove all jewelry.
- When the winch is in use, be sure to start the vehicle engine and set the gear position to "N."
- When the winch is working, it will draw voltage, so you must start the vehicle and step on the accelerator lightly to avoid damage to the battery.
- If severe noise or vibration occurs during the use of the winch, it must be

stopped immediately

- After the winch is used, if dirt such as soil and water stains are attached to the steel wire rope, please clean it in time and apply grease to prevent the steel wire rope from rusting and affecting the service life.
- When the winch is not used, please remove the controller.

⚠ WARNING

When releasing or retrieving the winch rope, both ends of the rope must be left with sufficient length to prevent the rope from being over-rolled in or out. When the rope is retrieving, please maintain a certain tension so that the rope can be retracted smoothly and can be wound tightly during retrieving.

⚠ WARNING

Always use the tow rope to pull the hook, do not hold the hook with your hands. This is not only important when winding the rope, but also when removing the rope from the winch under power.

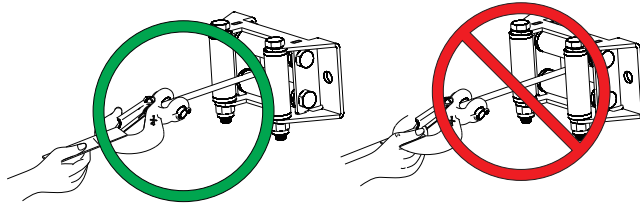

Winch Operation

Manual Release switch of Winch

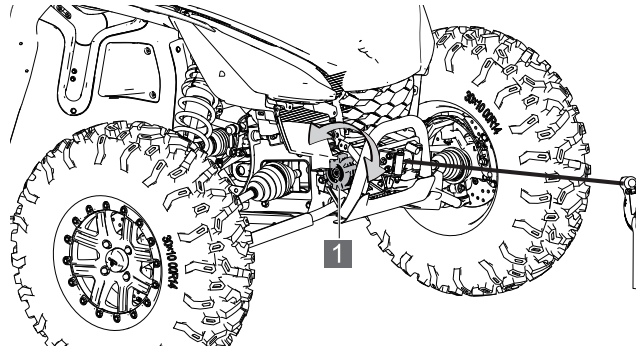

1 Manual release switch of Winch

- When the winch manual release switch is turned clockwise, the winch cable can be pulled out manually.
- When the winch manual release is switched (turned counterclockwise), the winch can be controlled by the switch.

Operation of control Switch

Remove the control switch from the passenger armrest storage and connect the control switch to the power interface of the winch located at the front of the vehicle.

1. Open the waterproof cover of the power interface of the winch switch.
2. Insert the control switch wire into the power interface.

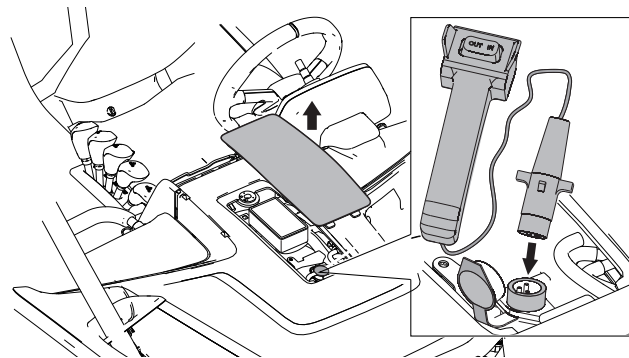

OUT: Release the winch cable

IN: Recoil the winch cable

Remote control operation

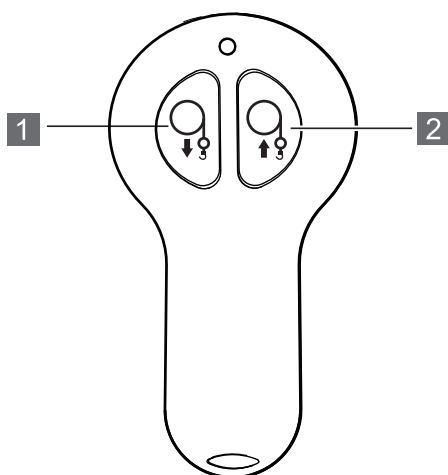

- 1** Release the winch cable
- 2** Reclaim the winch cable

NOTICE

When the remote control doesn't work, it may be that the battery in the remote control is exhausted. Replace the battery with a new one.

When the winch is needed, the rope should be aligned with the vehicle, preferably in a straight line. Too large an angle will change the direction of tension and damage the cable. In case of serious noise or vibration during the use of the winch, the operation of the winch must be stopped immediately.

MAINTENANCE





PERIODIC MAINTENANCE	4-1
LUBRICATING OIL	4-4
Front fluid recharging cover and electrical maintenance cover ...	4-4
Engine maintenance cover removal	4-5
Tool box removal.....	4-5
Ventilation cover removal.....	4-6
ENGINE OIL MAINTENANCE PROGRAM	4-7
Oil recommendation.....	4-7
Engine Oil Level Check	4-8
Changing engine oil&filter.....	4-9
Drain the engine oil.....	4-9
Add engine oil.....	4-11
FRONT/REAR GEARBOX (DEMAND DRIVE) FLUID	4-12
Check the level of rear gear box.....	4-12
Front/rear gearbox oil discharge.....	4-13
Add gear oil.....	4-13
COOLANT	4-14
Cooling bottle coolant	4-14
CVT belt.....	4-15
The CVT dry	4-16
BRAKE SYSTEM	4-17
Brake oil.....	4-17
Brake component.....	4-18
TIRE	4-19
Tire pressure.....	4-19
Tread depth of tire	4-19
Replace the tires.....	4-20
Wheel component removal.....	4-20
Tire replacement.....	4-21
SHOCK ABOSRBER.....	4-22
Shock abosrber preload adjustment.....	4-22



MAINTENANCE, STORAGE AND TRANSPORTATION

Damping adjustment of shock absorber.....	4-23
SUSPENSION DRIVE LUBRICATION	4-24
Front/rear drive shaft dust cover.....	4-24
AIR FILTER	4-25
Replace the air filter.....	4-25
Replace primary air filter.....	4-26
LAMP	4-27
Change the headlight.....	4-27
High beam adjustment.....	4-28
SPARK PLUG	4-29
Spark plug inspection	4-30
SPARK ARRESTER.....	4-31
BATTERY	4-32
Battery disassembly.....	4-32
Battery charging.....	4-33
Battery installation	4-34
FUSE	4-35
Fuse/relay distribution and rated amperage	4-35
Fuse box	4-36
Fuse box replacement	4-37
APPEARANCE CARE	4-38
Vehicle washing	4-38
Vehicle storage	4-38

PERIODIC MAINTENANCE

Periodic maintenance will help keep your vehicle in the safest, most reliable condition. Inspection, adjustment and lubrication of important components are explained in the periodic maintenance chart.

Inspect, clean, lubricate, adjust and replace parts as necessary. When in the need for replacement parts, use genuine Segway parts available from your authorized dealer.

Service and adjustments are important for proper vehicle operation. If you're not familiar with the service and adjustment procedures, have a qualified Segway dealer perform these operations.

Maintenance intervals in the following chart are based upon average riding conditions. Vehicles subjected to severe use and / or conditions must be inspected and serviced more frequently.

Severe use is defined as:

- **Frequent immersion in mud, water, or sand.**
- **Frequent or prolonged operation in dusty environments.**
- **Short trip cold weather operation.**
- **Racing or racing-style high RPM use.**
- **Prolonged low speed, heavy load operation.**
- **Extended idling.**

Maintenance Chart Key

Symbol	Description
▶	Perform these procedures more often for vehicles subjected to severe use.
D	Have an authorized Segway dealer or other qualified person perform these services.

WARNING

Improperly performing the procedures marked with a D could result in component failure and lead to serious injury or death. Have an authorized Segway dealer or other qualified person perform these services.

Perform all services at whichever maintenance interval is reached first. Record the maintenance and services in the Maintenance Log.

ITEM	MAINTENANCE INTERVAL (WHICHEVER COMES FIRST)			REMARKS
	HOURS	CALENDAR	MILES (KM)	
Steering		Pre-Ride		Visually inspect, test, or check components. Make adjustments and/or schedule repairs when required
Front suspension		Pre-Ride		
Rear suspension		Pre-Ride		
Tires/ Wheels/ fasteners		Pre-Ride		
Brake fluid level		Pre-Ride		
Brake system		Pre-Ride		
Accelerator		Pre-Ride		
Engine oil level		Pre-Ride		
▶ Air filter, pre-filter		Daily		Inspect. clean often. replace as needed
Coolant		Daily		Check level
Power steering unit (if equipped)		Daily		Inspect daily. clean often
Headlight/ taillight/ worklight		Daily		Check operation. apply dielectric grease if replacing lamps
▶ Air filter, main element		Weekly		Inspect. replace as needed
▶ D Brake pad wear	10 H	Monthly	100 (160)	Inspect periodically
Battery	20 H	Monthly	200 (320)	Check terminals. clean. test
Fuel System	20 H	Monthly		Inspect. cycle key to pressurize fuel pump. check lines and fittings for leaks and abrasion
▶ Engine oil change	25 H	1 M	200 (320)	Break-in oil and filter change
▶ Front gearcase oil	25 H	1 M	200 (320)	Break-in oil level check
▶ Rear gearcase oil	25 H	1 M	200 (320)	Break-in oil level check
▶ General lubrication	50 H	3 M	500 (800)	Lubricate all fittings, pivots, cables, etc.
Throttle Body Intake Duct	50 H	6 M	500 (800)	Inspect duct for proper sealing/air leaks
Drive belt	50 H	6 M	500 (800)	Inspect. adjust. replace as needed

ITEM	MAINTENANCE INTERVAL (WHICHEVER COMES FIRST)			REMARKS	
	HOURS	CALENDAR	MILES (KM)		
	Cooling system	50 H	6 M	1000(1600)	Inspect coolant strength seasonally. pressure test system yearly
▶	Engine oil change	100 H	6 M	1000(1600)	Change the oil and filter
▶	Oil lines and fasteners	100 H	6 M	1000(1600)	Inspect for leaks and loose fittings
▶	Front gearcase oil	100 H	12 M	1000(1600)	Change fluid.
▶	Rear gearcase oil	100 H	12 M	1000(1600)	Change fluid
D	Fuel system/filter	100 H	12 M	1000(1600)	Cycle key to pressurize fuel pump. check for leaks at fill cap, fuel lines/rail and fuel pump. replace lines every two years
▶	Radiator (if applicable)	100 H	12 M	1000 (1600)	Inspect. clean external surfaces
▶	Cooling hoses (if applicable)	100 H	12 M	1000 (1600)	Inspect for leaks
▶	Engine mounts	100 H	12 M	1000 (1600)	Inspect
	Exhaust muffler/ pipe / Joints	100 H	12 M	1000 (1600)	Inspect. clean. replace worn parts
D	Spark plug	100 H	12 M	1000 (1600)	Inspect. replace as needed
D	Clutches (drive and driven)	100 H	12 M	3700 (6000)	Inspect. clean. replace worn parts
D	Front wheel bearings	100 H	12 M	1000 (1600)	Inspect. replace as needed
D	Brake fluid	200 H	24 M	2000(3200)	Change every two years
	Spark arrester	300 H	36 M	3000(4800)	Clean out
▶	Coolant		60 M		Replace coolant
D	Valve clearance	500 H		5000 (8000)	Inspect. adjust
D	Toe adjustment				Adjust as needed
	Headlight aim				Adjust as needed

LUBRICATING OIL

Check and lubricate all components at the intervals listed in the periodic maintenance chart below. Items not listed in the chart should be lubricated in the general lubrication interval. The rocker arm is lubricated at the factory and does not require additional lubrication. However, if these components are used in severe conditions, the user may perform additional lubrication as required.

Project	Recommended model	Capacity	Inspection procedure
Engine oil	SAE10W-40/SJ or Higher	3.5 qts. (3800 ml)	Maintain level in safe range on dipstick
Front Differential	SAE 75/80W-90 GL5	0.16 qts. (180 mL)	Drive each 2000km Kilometers.
Rear Differential	SAE 75/80W-90 GL5	1.36 qts. (1500 ml)	
Coolant		8.63 qts. (9500 ml)	Maintain the level between the fill lines.
Brake fluid	DOT4		Maintain the level between the fill lines.
Suspension, balance bar grease		—	Grease nozzle (2 Pump max) per 500 mile.

Front Fluid Reservoir Cover and Electrical Maintenance Cover

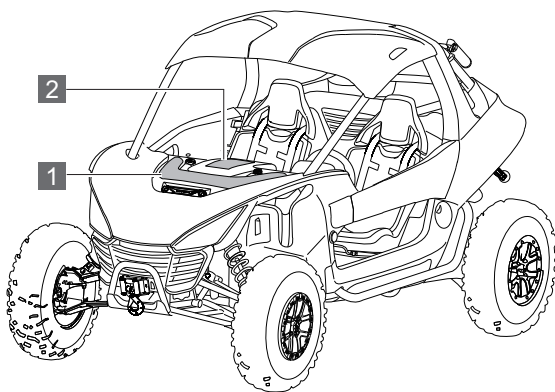

There are two snap-type removable cover plates located in the front of the vehicle. The fuse box is located under the electrical service cover and the brake fluid reservoir is located under the front cover.

- 1** Front fluid cover
- 2** Electrical service cover

Rear Cargo Bed

This is a detachable cargo bed. Rotate the lid of the cargo bed to disassemble the entire cargo bed.

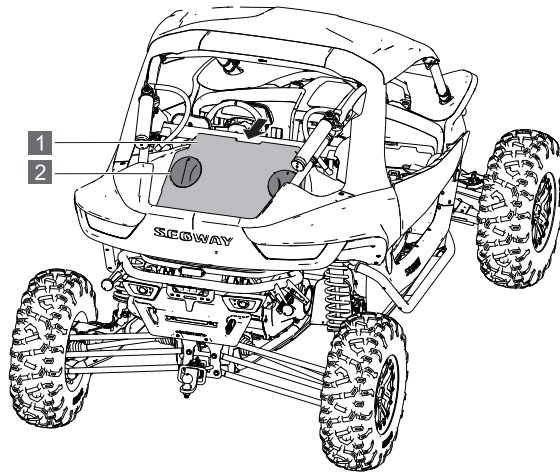

1 Rear Cargo Bed

2 Rear Cargo Bed Lid

Removal of rear cargo bed

The cargo bed is a snap-in quick-release structure. Hold the groove on the top of the cargo bed with both hands and move it backward to remove it.

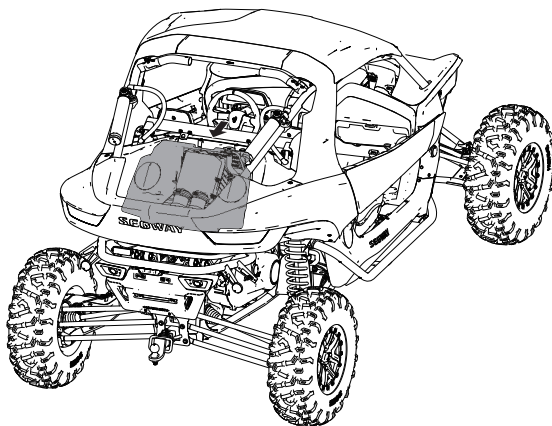

Removal of Air filter housing assembly

The air filter housing assembly needs to be removed during engine maintenance, and the spark plug and oil filling port are below

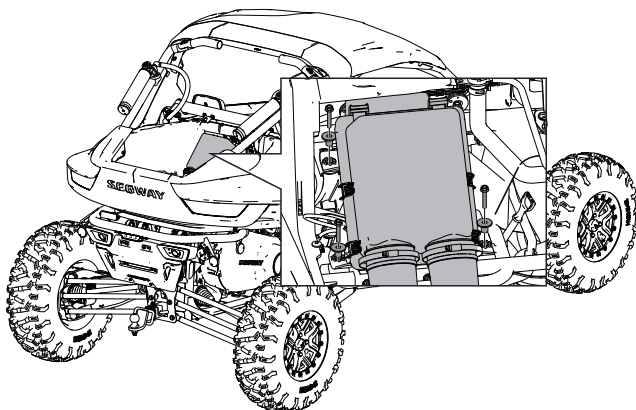

Remove the rear Cargo Bed

Loosen the M6×35 bolts fixing the air filter housing assembly with a tool, and remove the bolts and bushings.

At this time, the air filter housing assembly and the air filter inlet pipe joint can be turned up backwards, the spark plug is located below, and the spark plug can be replaced.

ENGINE OIL MAINTENANCE PROGRAM

Be sure to check and change the oil at the time required by the regular maintenance chart. Be sure to use the recommended engine oil. The oil filter must also be changed every time the oil is changed. Pay attention to the oil level. An increase in the oil level during cold weather can indicate contaminants collected in the oil sump or crankcase. If the oil level starts to rise, change the oil immediately. Monitor the oil level, if it continues to rise, stop using it and determine the cause. Your Segway dealer can assist.

⚠ WARNING

Vehicle operation with insufficient, degraded or contaminated engine oil will cause accelerated wear and tear, and may result in engine failures, accidents and/or injuries. Always perform the maintenance procedures listed in the periodic maintenance chart.

Oil Recommendation

The oil filter must be changed every time the oil is changed.

It is recommended to use 10W/40-SJ four-cycle oil or similar oil for this engine. Follow the manufacturer's recommendations for ambient temperature operation. Please refer to the lubricant guide section for fluid recommendations, capacity.

⚠ CAUTION

Mixing brands or using non-recommended oils may cause engine damage.

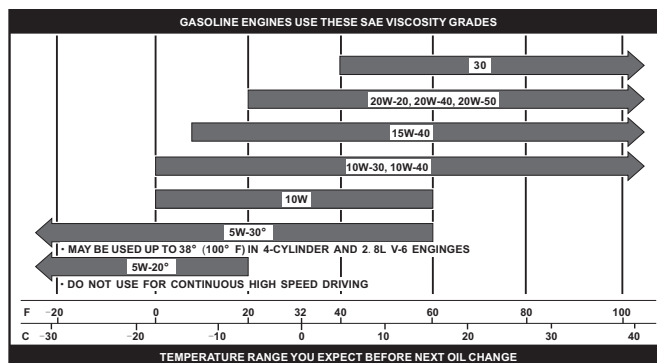

Engine Oil Level Check

NOTICE

Running the engine with an improper oil level can cause serious engine damage.

1. Park the vehicle on a level ground.
2. Remove the rear cargo bed.
3. Start the vehicle and let the engine idle for 5 minute, stand for 30 seconds.
4. Using a rag hold the end of the oil dipstick, and remove the oil dipstick from the engine.
5. Wipe the oil from the dipstick.
6. Reinsert the dipstick completely.
7. Pull the dipstick out and check the oil level.

Check the oil level as shown in the figure below. If the oil level is between the upper engraved line **1** and the lower engraved line **2**, it is the proper oil level. Below the lower scale means the oil is too low, and the upper scale means the oil is too full, too low or too full is not recommended.

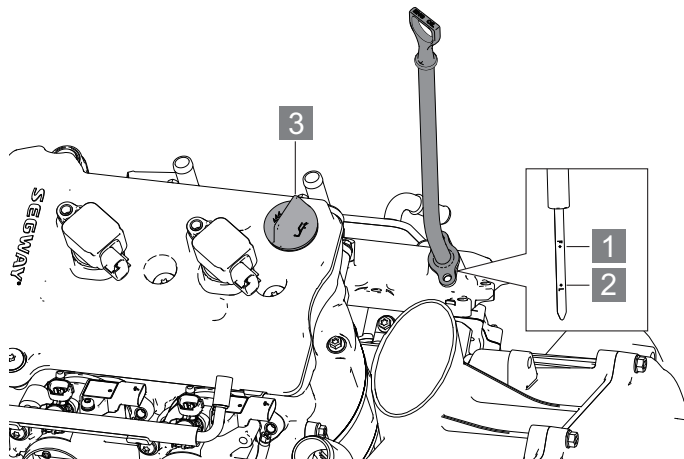

1 Upper Engraved Line **2** Lower Engraved Line **3** Oil Filler Cap

8. After cleaning the oil dipstick, insert and install it again.
9. If the oil level is near or below the lower level mark.
 - Removal of rear cargo bed (see page 4-5) .
 - Remove the oil fill cap **3** from the front right crankcase cover
 - Add the specified oil into the fill cap hole, up to the upper level mark on the dipstick.
 - Reinstall the oil fill cap and dipstick.

Changing Engine Oil&Filter

NOTICE

Whenever changing oil, change the oil filter.

⚠ WARNING

The used engine oil contains potentially hazardous pollutants, which can cause causes skin diseases such as dermatitis and skin cancer, so care should be taken to avoid prolonged and repeated exposure to such oils. Wash the skin thoroughly with soap and water to remove the used engine oil.

The used oil and filter must be disposed in a safe and compliant way with environmental regulations. Do not dispose used oil and filters in domestic garbage, sewers or on the ground. For information on oil recycling or scrapping, please consult your Segway dealer.

Do not put used engine oil in a place where children can reach.

Drain the Engine Oil

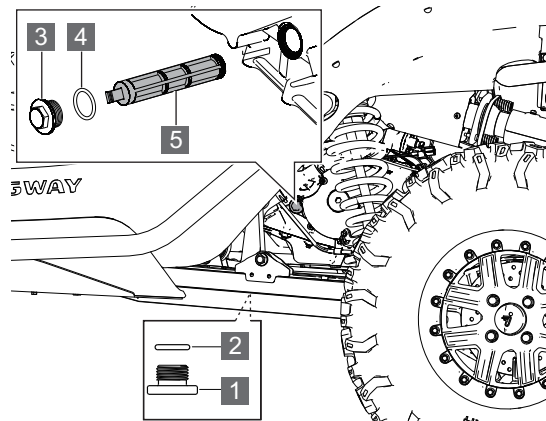

- 1 Oil Drain Plug
- 2 O-ring
- 3 Oil Filter Strainer
- 4 O-ring
- 5 Oil Drain Plug

There are two places on the engine where the oil can be drained, and both places should be drained, otherwise the waste oil cannot be drained completely.

Oil drain position 1

The oil drain position 1 is located at the bottom of the vehicle, under the engine

Oil drain position 2

The oil drain position 2 is located on the left side of the engine.

1. Put the vehicle on the horizontal surface.
2. Start the engine. Let it heat up for two to three minutes at idle.

! WARNING

Hot oil can cause skin burns. Don't let hot oil touch the skin

3. Place a suitable container under the oil drain plug **1** to collect the discharged waste oil
4. Remove the oil drain plug **1**, remove the O-ring and wait for the waste oil to drain completely
5. Place a suitable container under the oil drain plug **3** to collect the discharged waste oil
6. Remove the oil drain plug **3** and remove the O-ring **4**
7. Take out the oil filter strainer **5** and clean the oil filter. See P4-11 for details
8. Wait for the waste oil in drain position 1 and drain position 2 to drain completely

Torque

Oil Drain Plug: 16-20N.m(11.8-14.8ft-lb)

Replace Oil Filter/Oil Strainer

IMPORTANT

Change the oil filter and clean the oil strainer every time you change the oil

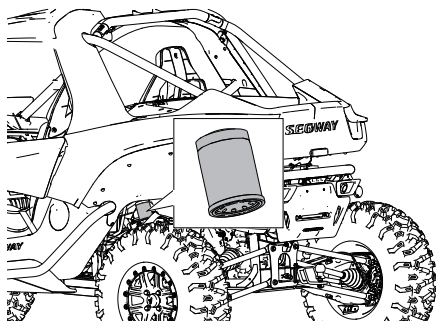
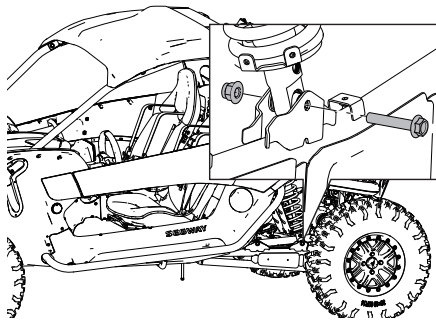

Change Oil Filter

- The oil filter is located inside the left rear wheel of the vehicle. Please refer to the fluid recommendation table for capacity and plug torque. Always change the filter at the same time as the oil change.

1. Use a jack to lift the rear of the vehicle to a certain height.
2. Remove the bolts under the left rear shock absorber, and place the shock absorber tilted back aside.
3. Unscrew the oil filter with a tool, and pay attention to the direction of the screw when unscrewing.
4. Install a new filter and manually rotate it clockwise until the filter gasket touches the sealing surface until it is tightened.
5. Re-fix the lower installation point of the left shock absorber with bolt M12×1.25×65.

Bolt M12×1.25×65

81~88 ft-lb (110~120N.m)

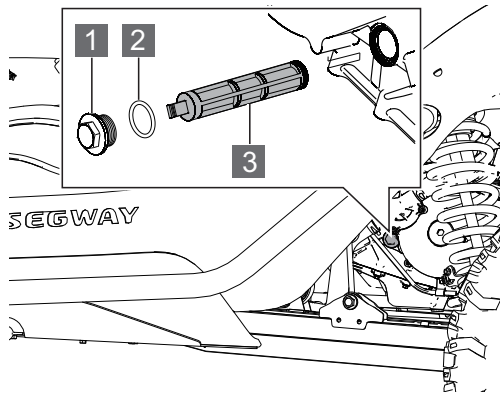

Oil Strainer Cleaning

- 1** Oil drain plug
- 2** O-ring
- 3** oil strainer

1. Remove the drain plug, take off the O-ring, and remove the oil strainer.
2. Clean the strainer and allow to dry.
3. Install new O-rings and reinsert the clean oil strainer.

Torque	Drain Plug: 16-20N.m(11.8-14.8ft-lb)
--------	---

Add Engine Oil

The engine oil filling port is located under the rear cargo bed. Remove the rear cargo bed (see page 4-5)

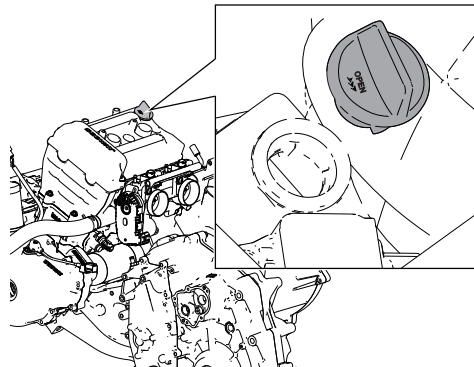

1. Unscrew the oil cap.
2. Add an appropriate amount of the recommended oil type and be careful to not overfill it. The correct oil level is between the upper scale and the lower scale marks.
3. Replace the oil cap.
4. Put the gear shifter in "Park."
5. Lock the parking brake.
6. Start the engine and let it idle for 5 minutes.
7. Stop the engine.
8. Check for any leaks.
9. Check the oil level and add oil as needed to make the oil level reach the mark on the dipstick.
10. Properly dispose any used filters and oil.

FRONT/REAR GEARBOX (DEMAND DRIVE) FLUID

Check and replace the demand drive fluid at intervals in the periodic maintenance chart. Replace the front gearbox fluid every 25 hours if the 4WD unit is exposed to extreme use. Extreme use includes any of the following:

- Continuous 4WD operations running
- In mountain or mountain areas for long periods of time in 4WD mode
- 4WD is the primary mode of all-wheel drive operations

⚠ CAUTION

If the front gearbox makes too much noise during 4WD operation, change the demand drive fluid. If the noise continues, see your Segway dealer.

Use the recommended oil type. The use of other oil may result in improper operation.

Check the Rear Gear Box Oil Level

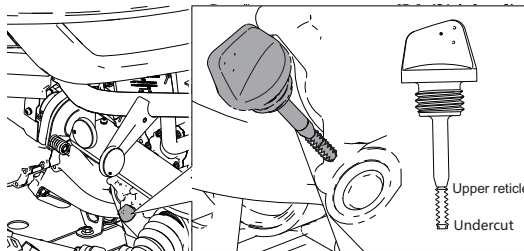

1. Park the vehicle on the level ground. If the engine is warm, wait at least five minutes to allow the oil to flow back into the bottom of the engine.
2. With a rag, remove and pull out the oil dipstick.
3. Clean the dipstick.
4. Re-insert the dipstick completely.
5. Check the oil level as shown in the figure above. The oil should be in the gradient marks. If not, add if the oil level is low.
6. Wipe the dipstick before reinstalling.

Front/Rear Gearbox Oil Change

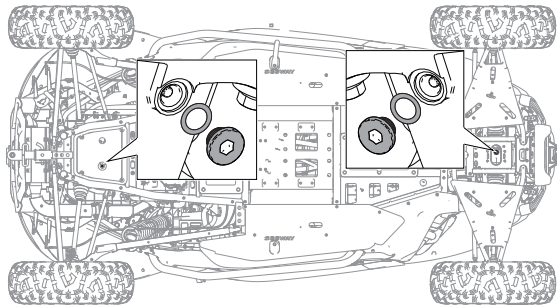

1. Place a container under the vehicle to collect the waste oil.
2. Put the vehicle on the horizontal surface and remove the injection plug and O ring.
3. Reinstall the injection plug after oil discharge is completed.
Torque to required value:

Torque

Drain Plug: 16-20N.m(11.8-14.8ft·lb)

Add gear oil

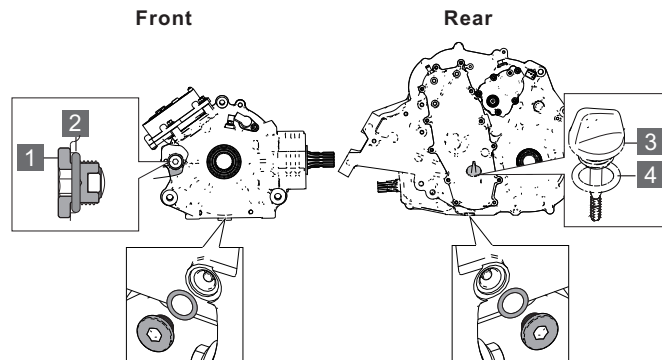

1 Filling Plug

2 O-ring

3 Oil Dipstick

4 O-ring

Torque

Filling Plug: 16-20N.m(11.8-14.8ft·lb)

1. Position the vehicle on a horizontal plane.
2. Place the drain tray under the demand drive unit.
3. Remove the drain plug. Allow the fluid to drain completely.
4. Clean and reinstall the drain plug.
5. Torque to desired value.
6. Add the recommended amount of oil.
7. Reinstall the drain plug.
8. Torque to desired value.
9. Check for any leakage.
10. Dispose used oil properly

COOLANT

The coolant circulates in the engine through the cooling system, taking away the excess heat generated during the engine operation and making the engine operate at normal operating temperatures. Maintaining the coolant will allow the cooling system to work properly and prevent freezing, overheating, and corrosion. Therefore, the coolant should be frequently checked. The factory provides a 50/50 solution of antifreeze and water in this SSV. This coolant solution is recommended for most operating temperatures and provides good corrosion protection.

Cooling Bottle Coolant

The coolant bottle is located under the cargo bed at the rear of the vehicle.

1. After removing the cargo bed, observe the liquid level in the bottle.
2. If the liquid level is low, remove the cap and add coolant as needed. Keep the coolant level between the minimum MIN and maximum markings MAX on the bottle (Measure when the liquid is cold).

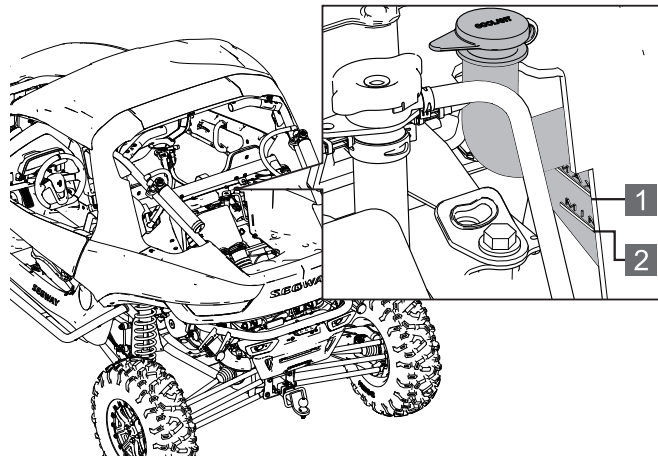

1 MAX

2 MIN

3. Unscrew the lid, pour in new coolant, pay attention to observe the position of the coolant when pouring in, and do not exceed the maximum liquid level.
4. Reinstall the cover.

Radiator Coolant

To ensure that the coolant maintains its ability to protect the engine, we recommend that the system be completely flushed every five (5) years with new antifreeze at a 50/50 premix.

⚠ CAUTION

A steam overflow can cause burns. Do not remove the pressure cap when the engine is warm or hot. The engine must be cooled before the pressure cap is removed.

Replace the coolant with a 50/50 premix of fresh antifreeze when any cooling system fluid is discharged for maintenance or repair. If the recovery bottle is empty, check the liquid level in the radiator and add coolant as needed.

1. After removing the cargo bed.
2. Remove the pressure cap.
3. Add the coolant slowly through the radiator filling port using a funnel.
4. Reinstall the pressure cap. The use of non-standard pressure caps will affect the normal operation of the recovery system. Your Segway dealer can provide the correct replacement parts.

CVT Belt

Replace the CVT drive belt according to the specified time listed in the vehicle maintenance schedule. If the belt is damaged, it should be replaced.

When replacing the belt, clean the CVT housing pipe, clutch and the engine compartment for debris.

⚠ WARNING

Failure to remove all debris when the belt is replaced can result in vehicle damage, loss of control and serious injury or death.

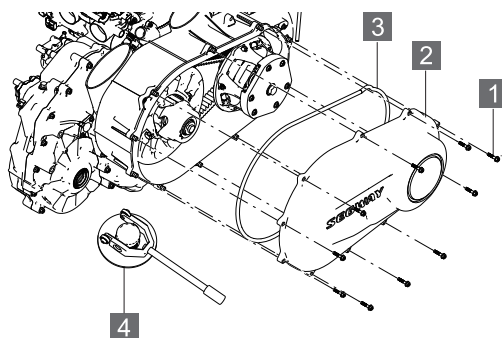

Stop the engine before replacement and allow the vehicle to cool down.

- 1 CVT cover bolt
- 2 CVT cover
- 3 CVT cover seal
- 4 CVT belt replacement tool

1. Remove the CVT outer cover bolts, outer cover and the sealing ring.
2. Remove the handle on the CVT belt replacement tool, and manually screw the CVT belt replacement tool into the thread of the CVT driven wheel.

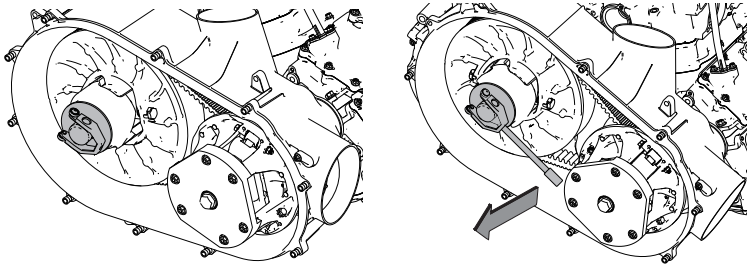

3. Insert the handle of the CVT belt replacement tool and pull the handle outward to open the CVT driven wheel.
 4. Remove the drive belt from the CVT driven wheel and driving wheel.
- If there are debris in the engine CVT inner box, please remove all debris completely.

Install the drive belt

The installation steps are basically the reverse of the removal.

1. Wrap the drive belt around the CVT driving wheel.
2. Use the CVT belt replacement tool to open the CVT driven pulley, wind the drive belt into the CVT driven pulley.
3. Install the CVT sealing ring and the CVT outer cover, tighten the CVT outer cover.

Torque	CVT cover bolt : 4.4 ft-lb. (6 N.m)
---------------	--

Drying the CVT

In some cases, the water may soak into the CVT system and must be dried out it before driving.

1. Place the transmission in "P" gear and pull up the parking handle.
2. Remove the CVT clutch drain plug.
3. Wait for the water to drain out and reinstall the water drain plug.
4. Start the engine.
5. Increase the engine speed and maintain it for 10-15 seconds to remove the excess moisture and dry the belt and CVT. DO NOT fully open the throttle during this operation.
6. Shift the vehicle to the low range and test for belt slippage.
7. If the belt still slips, repeat the process.
8. Visit your Segway dealer if your vehicle needs service.

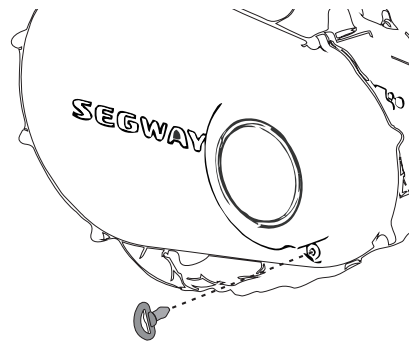

BRAKE SYSTEM

The front and rear brakes are hydraulic disc type brakes that are activated by the brake pedal.

⚠ WARNING
<ul style="list-style-type: none">• Brake fluid levels must be checked periodically.• Overfilling of the brake cylinder may cause brake resistance or brake locking, which may result in serious injury or death.• [this needs to be a bullet like the rest. I cannot change it in workd] Keep the brake fluid at the recommended level and do not overfill.• Must check brake disc brake disc wear condition regularly.

The following inspection is recommended to keep the braking system in good working condition. If the brake is in heavy use during normal operation, check it frequently.

1. Always keep the brake fluid at an appropriate level. Please refer to master cylinder/brake fluid section for details.
2. Check the braking system for any leakage.
3. Check whether the brake pedal stroke feels too long or feels soft.
4. Check whether the friction gasket is worn, damaged or loose. When replacing the brake gasket, the brake pad must be replaced when the remaining limit thickness of the brake pad is not less than 0.04 in (1mm).
5. Check the safety and surface condition of the disc. Use the recommended brake cleaner or liquid to clean any grease. Do not use spray lubricants or other petroleum-based products. If any damage (crack, excessive corrosion, warping) is found, please check with your Segway dealer before further operation.

Brake Fluid

Use the recommended brake fluid:

Brake Fluid	DOT4
--------------------	-------------

The hydraulic auxiliary brake system does not require adjustment. Check the brake fluid level of the auxiliary brake system frequently, and observe the brake fluid from the brake fluid sight hole cover on the front left side. If the display shows that the liquid level is low, perform the following operations.

1. Remove the front refill cap.

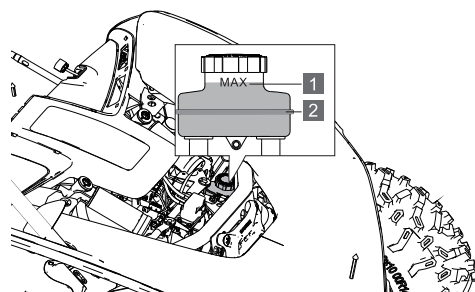

1 MAX **2 MIN**

The brake fluid level is most suitable between the Max and Min level indicators. If it is lower than the Min indicator, add the recommended brake fluid and observe the fluid level.

2. Check whether the brake pads are worn.

NOTICE

Brake fluid can damage plastic and painted surfaces and should be added with caution. If the brake fluid comes into contact with the skin or eyes, flush with plenty of water immediately. If you feel sick, seek medical attention immediately.

Brake pads and brake discs

The wear of brake pads and brake discs will depend on the severity of use and driving conditions. Brake pads wear faster in wet and muddy conditions. Regularly check the wear of the brake pads and brake discs according to the maintenance schedule. If the wear of the brake pads and brake discs exceeds the required value, the brake pads and brake discs must be replaced.

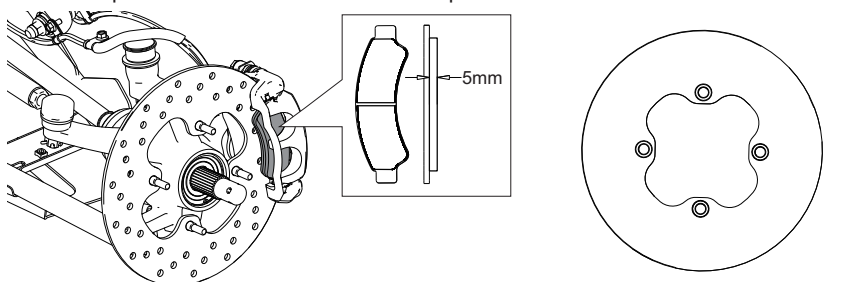

Brake pad thickness	Standard thickness	5.0mm	brake discs thickness	Standard thickness	5.0mm
	Minimum thickness	1.0mm		Minimum thickness	4.0mm

TIRE

Tire Pressure

Driving a vehicle with the incorrect tire pressure may result in the following consequences:

- Reduced fuel efficiency.
- Reduced driving comfort and shortened tire life.
- Reduction in safety

When checking tire pressure, use the following instructions:

Recommended tire pressures	Front wheels	Rear wheels
	18 psi (124 kPa)	18 psi (124 kPa)

- Allow the tire to cool down before checking pressure.
- If the vehicle has been parked for at least 3 hours, or has not driven more than 1 mi (1.5km), the check at this time can get an accurate reading of the cold tire inflation pressure.
- Tire appearance can sometimes be misleading. Even a few pounds less air in a tire can affect driving and handling performance.
- Increased tire pressure is normal after driving, do not reduce the tire pressure after driving.

Tread Depth

- Observe the tire wall to find the Tire Wear Indicator (TWI), follow the triangle sign to see limit. When the tread reaches the top of the indicator, it is time to replace the tire(s).

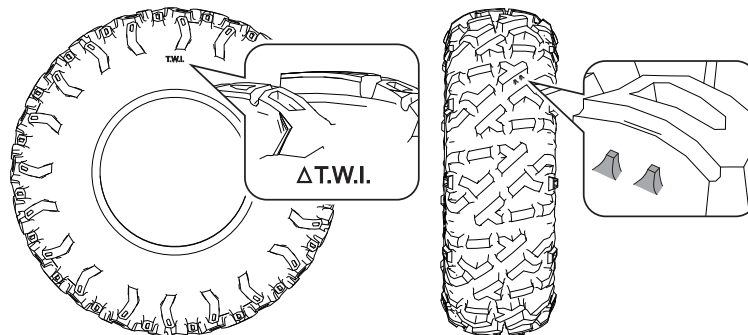

When to Replace a tire :

- If tire is damaged, such as a cut, delamination, or a deep crack of the sidewall, or a bulge is all indications that the tire is damaged.

- Tires often have air leaks and cannot be normally repaired due to the size or position of the area of the leak. If you are not sure, consult your Segway dealer.

Replace the Tires

When the tire tread wear has reached the replacement mark or the tire is damaged due to an external impact, the damaged tire should be replaced.

Wheel Removal

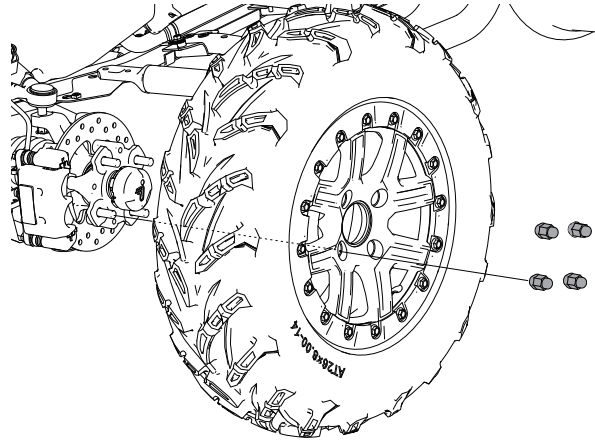

Torque Specification:

Torque	Mounting nuts: 74-88 ft-lbs. (100~120N·m)
--------	---

1. Stop the engine.
2. Put the gear shifter in "P" position.
3. Lock parking brake.
4. Lift the side of the vehicle by placing a suitable jack under the frame.
5. Loosen the four hub mounting nuts.
6. Remove the wheel.

⚠ CAUTION

A loose nut may cause the tire to fall off during operation, which may cause an accident or rollover. Always ensure that all nuts are tightened to the required value 74-88 ft-lbs. (100~120N·m) . Do not use lubricating oil or grease on wheel bolts or wheel nuts. Lubricating oil or grease may cause excessive tightening of wheel nuts, resulting in damage to the wheel bolt or wheels. In addition, lubricating oil or grease can cause wheel nuts to become loose and wheels may fall off, which can lead to accidents and serious injuries. Remove any lubricating oil or grease from wheel bolts or wheel nuts.

Tire Replacement Size

⚠ WARNING

Do not use wheels of different sizes than recommended in the User's Manual as this can cause the vehicle to lose control.

The recommended size	The front wheel	The rear wheel
	29×9.0R14/30×10.00R14	29×11R14/30×10.00R14

SHOCK ABOSRBER

Shock abosrber preload adjustment

The spring adjusting nut of the air pressure damping shock absorber is at the upper end of the spring. Use a crescent wrench to loosen the lock nut. Then turn the adjusting nut to loosen.

Adjust the nut position according to the range of the table below to achieve the required comfort

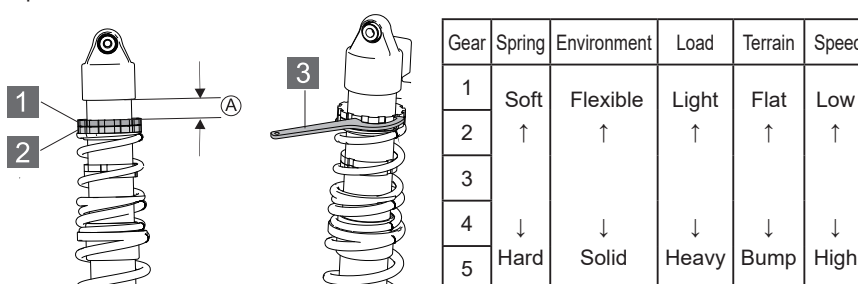

1 Locknut **2 Adjusting Nut** **3 Crescent wrench** **A Spring preload position**

Screw the locknut to the desired position, then unscrew the adjusting nut to adjust the position of the nut.

Setting standard of spring preload position:

Item	Factory setting	Available range
Front shock absorber: Air pressure adjustable damping spring preload setting position (From the bottom of the upper mounting seat to the position of the adjusting nut)	64" Narrow version 35mm(1.4in.)	20~45mm(0.8~1.8in.)
	72" Wide version 85mm(3.34in.)	65~95mm(2.6~3.74in.)
Rear shock absorber: Air pressure adjustable damping spring preload setting position (From the bottom of the upper mounting seat to the position of the adjusting nut)	64" Narrow version 35 130mm(5.1in.)	120~150mm(4.73~5.9in.)
	72" Wide version 170mm(6.7in.)	170~210mm(6.7~8.37in.)
High-speed compression damping adjustment (clockwise adjustment)	Third Level	1-9 Level
Low speed compression damping adjustment (clockwise adjustment)	First circle	0-2.5 circle
Restoration damping adjustment (adjusted from clockwise)	First Level	1-14 Level
Gas pressure	1Mpa	

Damping adjustment of shock absorber

In order to adapt to various riding conditions, the preload of the spring can be adjusted by shock absorber or spring replacement. Damping force can also be easily adjusted without changing oil viscosity

Compression damping adjustment

- Use a 16mm sleeve to turn the compression damping adjuster **2** on the upper part of the split cylinder block to adjust the compression resistance at high-speed vibration frequencies. The damping in the clockwise direction (H) is increased, and the damping in the counterclockwise direction (S) is decreased.
- Use a flat-blade screwdriver to turn the compression damping adjuster **1** on the upper part of the split cylinder block to adjust the compression resistance at low-speed vibration frequencies. The damping in the clockwise direction (H) is increased, and the damping in the counterclockwise direction (S) is decreased. The compression damping regulator has a total of 8 level, the factory setting gear is the first level

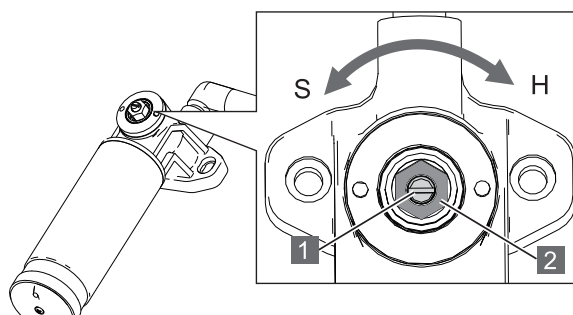

Restoration damping adjustment

Use a flat-blade screwdriver to turn the damping adjuster at the bottom, instantaneously adjust the damping in the needle direction (H) and decrease the damping in the counterclockwise direction (S). The restoration damping regulator has 12 level, and the factory-set gear is the 6th level

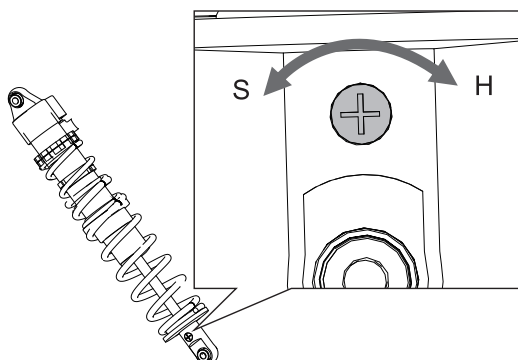

LUBRICATION

The vehicle's front suspension, rear suspension, drive shaft and balance parts are installed with grease fitting. If you see the label below, there is a grease spot nearby.

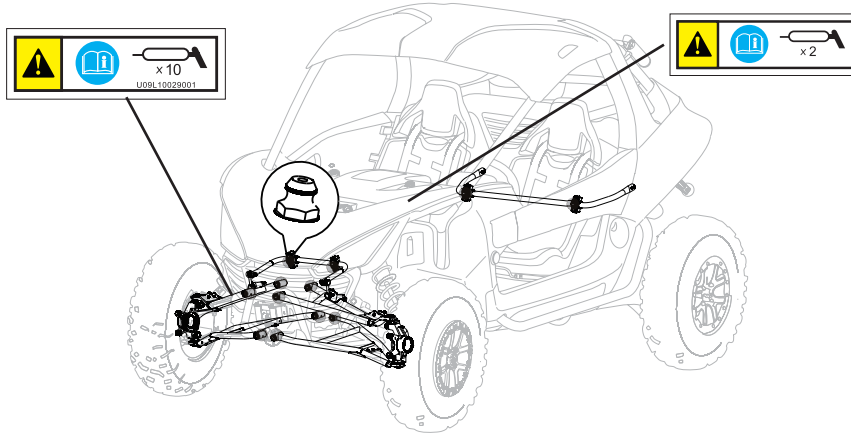

These parts on the vehicle need sufficient lubrication. Lubrication can reduce the wear of these parts, and increase the service life of the vehicle. Follow the periodic maintenance table to add appropriate grease at the right intervals.

Front/Rear Drive Shaft Dust cover

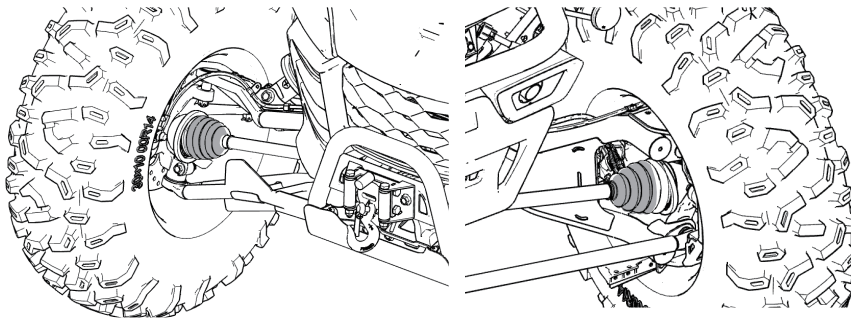

Check for cuts, damage or grease leakage in the front and rear drive shafts dust boots. If you find an damage or grease leakage, please contact your Segway dealer for replacement.

AIR FILTER

The vehicle utilizes a two-stage air filtration system. The air passes through the primary filter first and then the secondary air filter last. This two-stage air filtration system fully meets the needs of the engine.

⚠ WARNING

The primary air filter must be replaced every time when the air filter element is replaced

Replacing the Secondary Air Filter

The air filter element of this vehicle is a paper air filter element. The filter needs to be replaced after a period of use. For details, see the periodic maintenance table (page 4-2).

Removal of the air filter cover

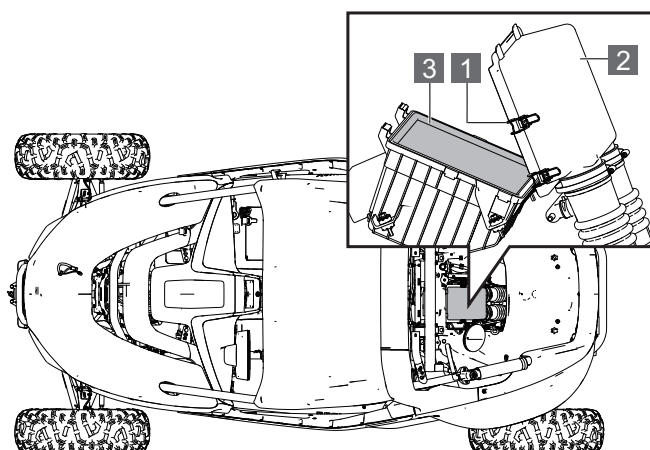

- 1** Air filter cover snap **2** Air filter cover **3** Air Filter element

The air filter is located under the rear storage box, see the disassembly steps (page 4-5).

1. Remove the 4 buckles **1** of the air filter cover, and lift the air filter cover **2** together with the intake pipe.
2. Take out the air filter element **3**.
3. Take the filter element out of the box, replace the filter element for cleaning or replacement.
4. Reinstall the filter element on the filter.
5. Reinstall the air filter cover.

Air filter inlet cap and CVT inlet mesh fabric

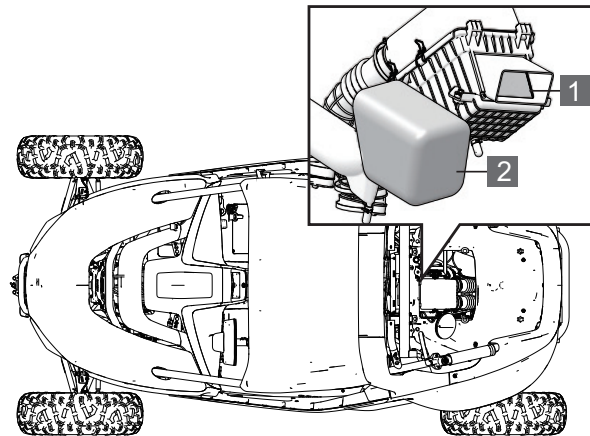

1 Air filter inlet cap

2 CVT inlet mesh fabric

Check the air inlet cover of the air filter and the cover of the CVT air inlet pipe network every time the air filter element is replaced.

The air inlet cover of the air filter is at the front of the air filter. See page 4-6 for disassembly steps. The cover of CVT air inlet pipe network is located next to the air filter. After removal, the storage box can be seen. Clean it if necessary, and replace it if damaged.

⚠ WARNING

When assembling the filter element, please make sure that the buckles of the filter element and the end cover are installed in place, otherwise it will cause the engine to malfunction or reduce the service life

When the vehicle is driving in a dusty environment, please shorten the time interval for checking the filter element

The air filter is soaked or the filter element is wet, please drain the water and replace the filter element

LAMP

⚠ CAUTION

Poor lighting can result in reduced visibility while driving. Please clean the headlamps frequently and replace non-working headlamps promptly. To ensure optimum visibility and safety, make sure the lights are properly adjusted.

Change the Headlight

LED Lights

LED lights consist of multiple lights. If any LED burns out, please send the vehicle your Segway dealer for replacement.

⚠ CAUTION

Hot bulbs can cause skin burns. Allow the lights to cool before any maintenance is performed. DO NOT touch the headlight bulbs. Fingerprints on the bulbs will cause premature light failure.

Removal of the Headlight:

1. First remove the expansion screws on the headlight shield.
2. Remove the headlight bolts (2pcs).
3. Remove the headlight guard.

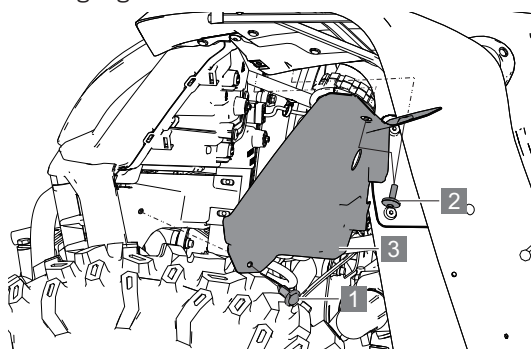

- 1** Expansion screw **2** Headlight bolts **3** Headlight Shield

High beam adjustment

The headlight beam can be adjusted slightly up/down. Use the following procedure to make adjustments of the headlight.

⚠ CAUTION

The following pictures are for reference only. Your model may be slightly different.

It is best for a Segway dealer to adjust if conditions permit.

1. Place the vehicle on a horizontal plane with a headlight position of about 32 ft (10m).

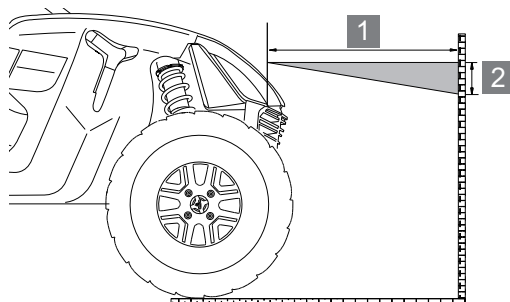

2. Measure the distance from the floor to the center of the headlights and mark the walls at the same height.
3. Start the engine. Adjust the headlight switch to high beam.
4. Watch the headlights aim at the wall. The strongest part of the headlight beam should be 2 in (5cm) below the mark on the corner.

Adjust the headlight beam upwards and downwards

To raise the headlight beam, turn the headlight adjusting screw counterclockwise.
To lower the headlight beam, turn the headlight speed adjustment screw clockwise.

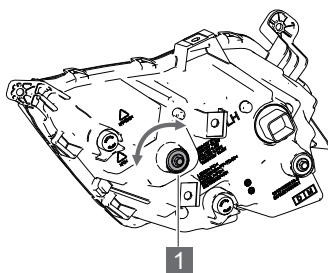

1 Light adjusting screw

Adjust the headlight beam left and right

The headlight beam can be adjusted from left or right.

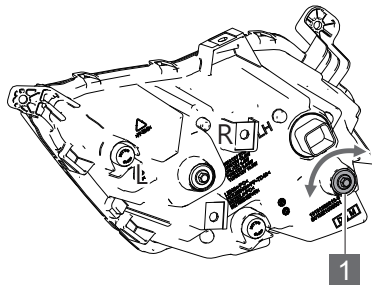

1 Light adjusting screw

To turn the headlight beam to the left, turn the headlight adjustment screw counterclockwise.

To turn the headlight beam to the right, turn the headlight speed adjustment screw clockwise.

SPARK PLUG

Refer to the specification below for the recommended spark plug type and clearance specifications.

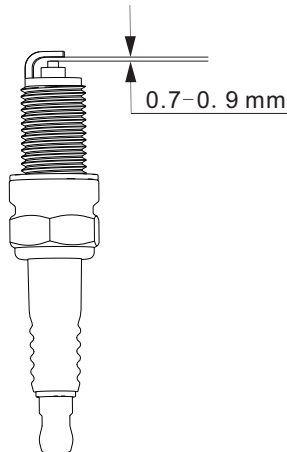

CAUTION

Using spark plugs that are not recommended can cause serious engine damage.

Always use recommended spark plugs or their equivalents. Replace both spark plugs at the same time

	Model
Spark Plug	NGK CPR7EA /TORCH B7RTC
	Spark Plug Clearance
	0.7-0.9mm

Spark Plug Inspection

The spark plug condition indicates how the engine is running. Check or change the spark plugs within the maintenance time shown in the periodic maintenance schedule.

⚠ CAUTION

Allow the engine to cool before attempting to remove the spark plug for inspection. Hot exhaust system and engine will cause burns

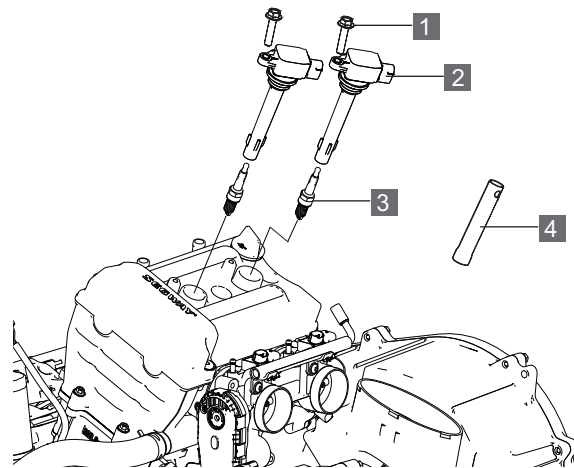

1 Bolt **2 Ignition coil** **3 Spark plug** **4 Spark plug sleeve**

The spark plug is located under the rear cargo bed and the air filter. First remove the rear storage box (see page 4-5), and then remove the air filter (see page 4-6):

1. Remove the ignition coil bolts.
2. Pull out the ignition coil.
3. The spark plug is located below the ignition coil. Use tool to turn the spark plug cap 1/4 and remove it from the spark plug.
4. Rotate the spark plug counterclockwise and remove it.
5. Inspect the spark plug.

Normal spark plug : The electrode part is grayish white, grayish yellow or light brown, and the electrode gap is about 0.7-0.9mm.

If the spark plug shows electrode wear, carbon deposits or, clearance is too large replace the spark plugs.

SPARK ARRESTER

Spark arrester prevents random sparks from entering other parts of the vehicle. Regular maintenance can prevent carbon accumulation, maintenance will reduce engine performance if the maintenance is not done.

⚠ WARNING

Make sure the exhaust pipes are cool.
Ensure that there are no combustible materials in the area when maintaining the vehicle.
Safety glasses are recommended in this procedure.

The exhaust pipe must be cleaned periodically of any accumulated carbon :

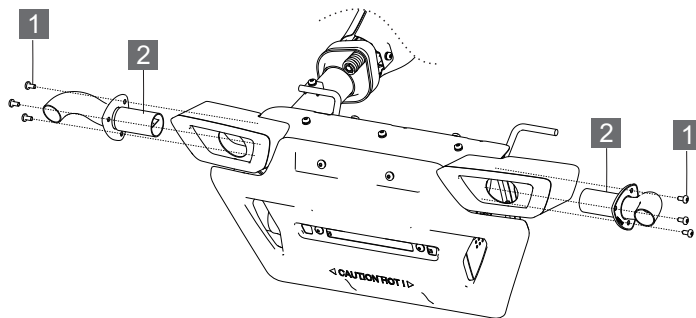

1 Pan head screw M6×12

2 Muffler spark arrester

1. Remove the six fastening bolts on the left and right muffler spark arrester **1**.
2. Disassemble the muffler spark arrester.
3. Use a non-synthetic brush to clean the arrester screen. A synthetic brush may melt if components are warm. If necessary blow debris from the screen with compressed air.
4. Inspect the screen for any wear or damage. Replace a worn or damaged screen.
5. Reinstall the muffler spark arrester and fastening screws.

BATTERY

Due to natural discharge and leakage effects of some electrical equipment, the 12V battery will discharge gradually even when the vehicle is not in use. If the vehicle is parked for a long time, the 12V battery may discharge and may not start. Please charge the battery slowly one time a month if not in use. This will maintain the battery life cycle.

WARNING

12V batteries contain toxic and corrosive sulfuric acid and may produce flammable explosive hydrogen gas. To reduce the risk of serious injury or death, the following precautions should be observed when handling 12V batteries or working near them:

- Do not smoke or light a match near a 12V battery.
- Avoid splashing electrolyte on eyes, skin and clothes.
- Wear safety goggles when working near 12V battery.
 - Keep children away from 12V batteries.

Be sure to charge the 12V battery in an open area. Do not charge a 12V battery in a poorly ventilated garage or enclosed room.

Battery Removal

NOTICE

If the electrolyte overflows, immediately wash it off with a solution of 1 tablespoon baking soda and 1 cup water to prevent damage to the vehicle.

The battery is located behind the driver seat. If you want to replace or maintain the battery, please remove the seat first (see page 2-8 for details).

Turn the power off before removing battery.

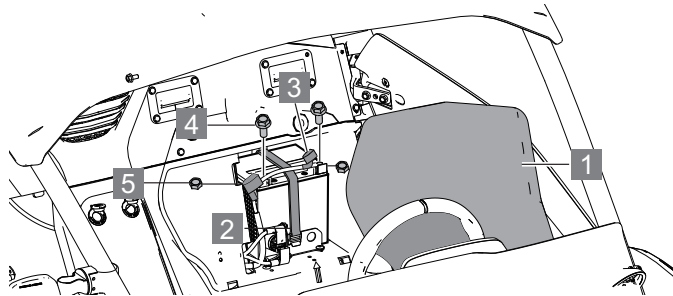

- 1 Battery Guard** **2 Battery pull strap** **3 Protective rubber sleeve**
4 Positive and negative anchor bolts for cable
5 Positive and negative anchor nuts for cable

1. Hold the groove behind the battery guard plate with your hands and move it forward, and remove the battery board.
2. Remove the battery strap.
3. Flip the protective rubber sleeve up.
4. Remove the negative pole screw and disconnect the black (negative) battery cable.
5. Remove the positive pole screw and disconnect the red (positive) battery cable.
6. Remove the battery from the vehicle.

Battery Charging

⚠ CAUTION

When charging, the hydrogen produced by the 12V battery is combustible explosive gas. Please follow the following precautions before charging:

If charging the 12V battery is still installed in the vehicle, be sure to disconnect the ground cable.

Make sure the power switch on the charger is off when connecting and disconnecting the charger cable to the 12V battery.

Only charge slowly (5A or less), if not the 12V battery may explode.

Measures to be taken in an emergency

1. Connect the clamp of the positive jumper cable to the special jumper starting terminal of the vehicle.
2. Connect the clamp on the other end of the positive cable to the positive (+) terminal of another vehicle.
3. Connect the negative cable clamp to the negative battery terminal of another vehicle.
4. As shown, connect the clamp on the other end of the negative cable to a separate clamp.

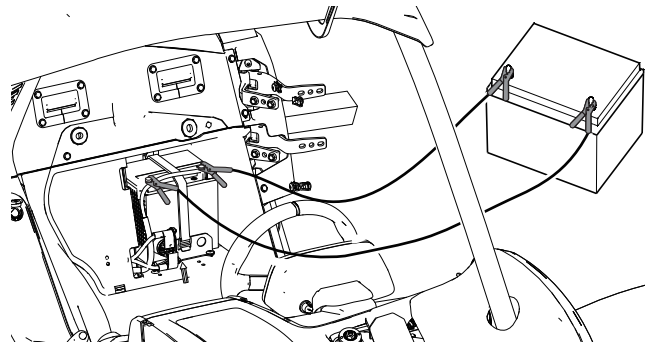

Battery Installation

NOTICE

To reduce the chance of sparks, disconnect the black (negative) cable first. When reinstalling the battery, install the black (negative) cable last.

1. Clean battery cables and terminals with a hard wire brush. Corrosion can be removed with a solution of 1 cup water and 1 tablespoon baking soda. Rinse well and dry thoroughly.
2. Put the battery in the tray.
3. Connect and tighten the red (positive) cable.
4. Connect and tighten the black (negative) cable.
5. Install the battery press plate.
6. Tighten the battery clamp bolt.
7. Verify that cables are properly wired.

FUSE

All circuits on the vehicle have fuses to protect electrical equipment from damage caused by high current (short circuit or overload).

If any of the electrical parts do not work, the fuse may have blown. If this happens, check and replace the fuse if necessary. You can consider electrical faults, first check whether the fuse needs to be replaced, if it is found to have blown, replace the blown fuse. There is a spare fuse in the fuse box. Check all fuses for other possible causes. Replace all blown fuses and check the working condition of components. All fuses are concentrated in the fuse box. In the event of a system failure, see "Fuse Distribution and Ampere rating" for details of which fuses to check.

NOTICE

- Do not use a fuse above the rated ampere value or replace it with anything else.
- Please use the same product. Never use wires for fuses, even temporary replacements are not allowed.
- Do not modify fuses or fuse boxes.

Fuse Box

The fuse box is located under the front instrument panel. Remove the front panel repair cover as shown in page 4-4.

After the front panel repair cover has been removed, the fuse box is located at the bottom. Move the clasp on the left and right sides of the fuse box cover. Loosen the clasp and open the fuse box.

NOTICE

Pay attention to the direction of installation.
The label may be slightly different from the image below.

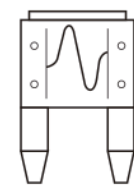

Normal fuse

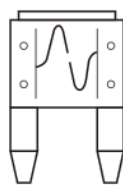

Blow fuse

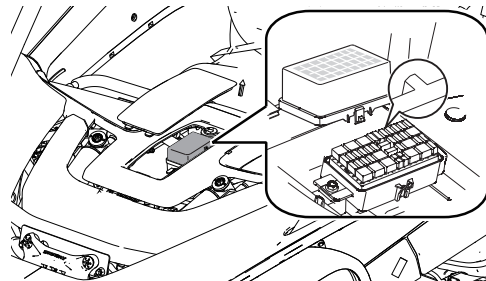

Fuse/Relay Distribution and Rated Amperage

There is a. You can refer to the fuse distribution label on the top of the fuse box cover to find a fuse of the same power for replacement.

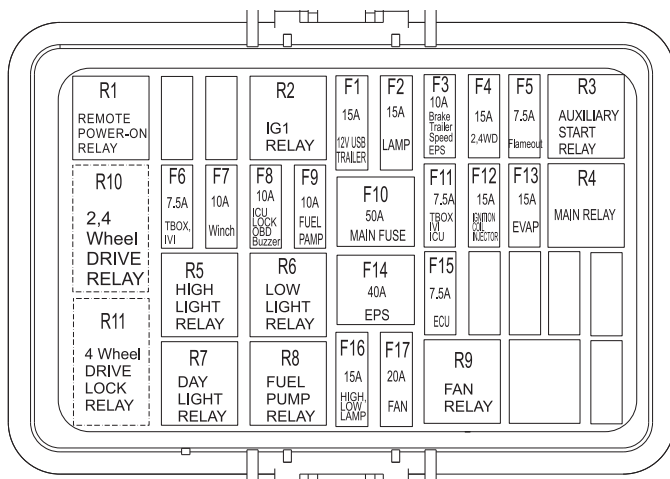

Rated amperage of fuse/relay and distribution

No.	Fuse/Relay	Power
F1	12V,USB,Trailer	15A
F2	LAMP	15A
F3	Brake,Trailer,Speed,EPS	10A
F4	2-4WD	15A
F5	Flameout	7.5A
F6	TBOX,IVI	7.5A
F7	Winch	10A
F8	ICU,LOCK,OBD,Buzzer	10A
F9	FUEL PUMP	10A
F10	MAIN FUSE	50A
F11	TBOX,IVI,ICU	7.5A
F12	IGNITION COIL,INJECTOR	15A
F13	EVAP	15A
F14	EPS	40A
F15	ECU	7.5A
F16	High/Low LAMP	15A
F17	FAN	20A

R1	Remote power-on relay	12V 20A
R2	IG1 relay	12V 20A
R3	Auxiliary start relay	12V 20A
R4	Main relay	12V 20A
R5	High light relay	12V 20A
R6	Low light relay	12V 20A
R7	Day light relay	12V 20A
R8	Fuel pump relay	12V 20A
R9	FAN relay	12V 20A
R10	2-4 Wheel drive relay	12V 20A
R11	4 Wheel drive lock relay	12V 20A

Fuse box Replacement

To prevent an accidental short circuit, turn the ignition switch to the (OFF) position and check or replace the fuse(s).

To check or replace the circuit fuse, pull out the old fuse with a puller.

The fuse box cover is equipped with a puller. Using this tool will help you take out the fuse.

The fuse box cover is fitted with a common fuse which can be replaced.

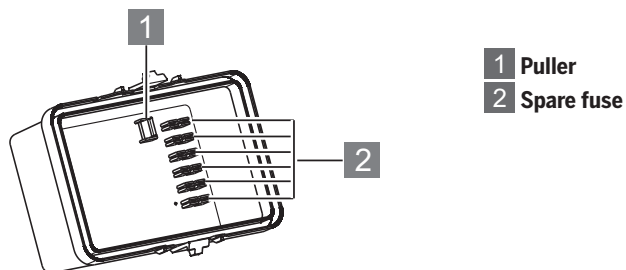

NOTICE

If a replacement fuse suitable for the circuit rating is not available, install a lower rated fuse.

APPEARANCE CARE

Vehicle Washing

High pressure water can damage parts and remove paint and decals.

1. Cover or plug the exhaust outlet prior to washing your SSV.
2. Fill a bucket with water. Mix in a mild, neutral detergent, such as dish washing liquid or a product made especially for washing motorcycles or automobiles.
3. Wash your SSV with a sponge or soft towel. As you wash, check for heavy grime. If necessary, use a mild cleaner/degreaser to remove the grime.
4. After washing, rinse your SSV thoroughly with plenty of clean water to remove any residue. Detergent residue can corrode alloy parts.
5. Dry your SSV with a chamois or a soft towel. Leaving water on the surface to air dry can cause dulling and water spots. As you dry, inspect for chips and scratches.
6. As a precaution, ride your SSV at a slow speed and apply the brakes several times. This will help dry the brakes and restore normal braking performance.

Vehicle Storage

When the vehicle is not used for a long time, it should be appropriately stored. The vehicle should be parked and cleaned. If there is no indoor storage, covered outdoor storage is recommended.



SPECIFICATIONS OF VEHICLE	5-1
THE FRAME NAMEPLATE	5-3
VEHICLE IDENTIFICATION NUMBER.....	5-4

SPECIFICATIONS OF THE VEHICLE

ITEM		PARAMETERS	
Length×width×height		3380mm×1850mm×1850mm	
Wheelbase		2590mm	
Front wheelbase		1570mm	
Rear wheelbase		1575mm	
Curb weight		880kg	
Ground clearance		380mm	
Turning diameter		13000mm	
Height of seat from ground		620mm	
Steering wheel diameter		310mm	
Maximum weight capacity		260 kg	
Carrying load		90 kg	
Reserve fuel volume		5L	
Rim type and specification	Front wheel	Aluminum rim (14×6.5J)	Anti drop aluminum rim (14×6.5J)
	Rear wheel	Aluminum rim (14×7.0J)	Anti drop aluminum rim (14×7.0J)
Tire type and specification	Front wheel	29×9.00R14	30×10.00R14
	Rear wheel	29×11.00R14	30×10.00R14
Tire pressure	Front wheel (PSI/kPa)	18PSI (124kPa)	18PSI (124kPa)
	Rear wheel (PSI/kPa)	18PSI (124kPa)	18PSI (124kPa)
Driving brake	Type	Hydraulic, disc type, H type	
	Operation Mode	Foot operation	
Parking brake	Type	Mechanical	
	Operation mode	Hand operation	
Suspension type	Front	Double wishbone independent suspension	
	Rear	Multi-link independent suspension	
Shock absorber type	Front	Hydraulic spring-external airbag	
	Rear	Hydraulic spring-external airbag	

Air filter type		Paper filter type
Muffler type		Impedance
Engine type		Parallel double cylinder, water cooling, four stroke
Engine model		293MY
Displacement		999.9 cm ³
Compression ratio		10.9 : 1
Bore diameter (mm) × stroke (mm)		93mm×73.6mm
Starting method		Electric start
Ignition type		Electricity(ECU)
Spark plug type		NGK CPR7EA /TORCH B7RTC
Spark plug clearance		0.7~0.9mm
Lubrication method		Pressure splash
Cooling method		Liquid cooling
Coolant capacity		9500 mL
Lubricant type	Engine	SAE10W-40/SJ or Higher
	Front axle gear	SAE 75/80W-90 GL5
	Gearbox	SAE 75/80W-90 GL5
Lubricating oil capacity	Engine	3800mL
	Front Axle	250mL
	Gearbox	1500mL
Fuels(Gasoline Unleaded)		87#
Fuel tank capacity		44L
Total volume of storage box		8L
CVT transmission ratio		0.891~3.608
Headlight	Headlamp Driving beam	28.4W
	Headlamp Passing beam	14.9W
	Front position lamp	2.4W
	Daytime running lamp	27.6W
	Front direction indicator	21.6W
	Illumination of headlamp (single)cd	21.6W
Rear light	Rear brake light color/specification	Red/12.78 W
	Rear position light color/specification	Red/2.12 W
	Rear turn signal color/specification	Amber/2.32 W

Color/Specification of Rear License Plate Light		White/2.5 W
Battery capacity		12V/32Ah
Shift operation mode		Mechanical
Auxiliary DC Outlet		12V
Instrument		TFT
Central control screen (inch) (optional)		10.6
Seat belt	Driver	Four-point roll-up
	Passenger	Four-point strap
Power output mode	Shaft drive	
Front winch (lb/m)	3500 (4500 optional)	

THE FRAME NAMEPLATE

The vehicle nameplate is located under the cargo box on the right rear of the vehicle, the nameplate shows the basic characteristics information which include VIN code. It needs the VIN when the vehicle requires activate in the first time.

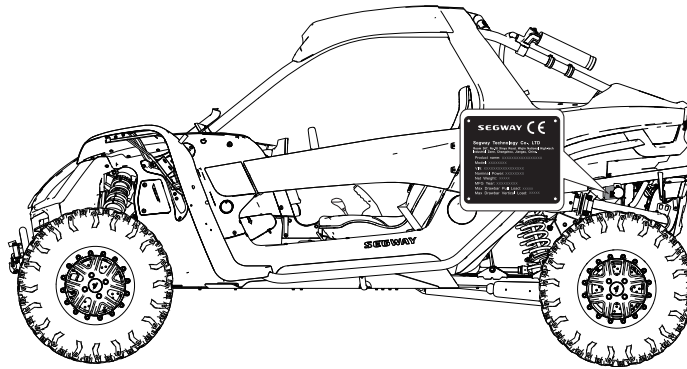

VEHICLE IDENTIFICATION NUMBER(VIN)

Record the frame identification code and engine serial code in the spaces provided for assistance when ordering spare parts from a dealer or for reference in case the vehicle is stolen.

The frame number is located on the frame tube on the lower right rear side of the vehicle.

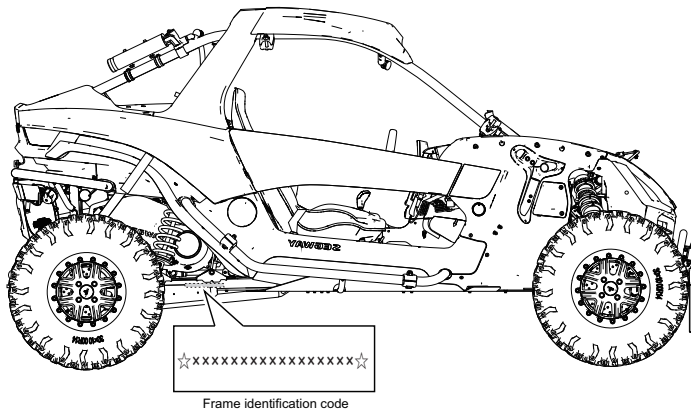

Frame identification code	
---------------------------	--

The engine number is stamped on the engine.

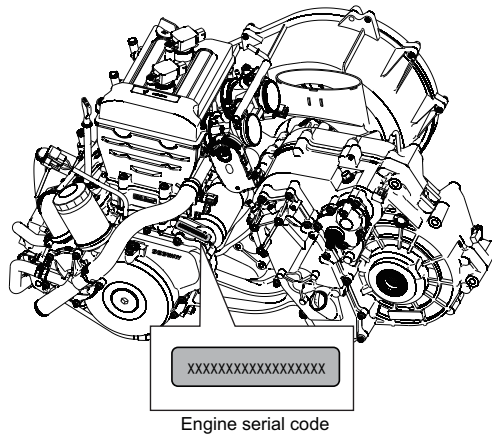

Engine serial code	
--------------------	--



TROUBLESHOOTING

Drive belt and cover problems	6-1
Engine doesn't turn over.....	6-2
Engine pings or knocks.....	6-2
Engine stops or loses power.....	6-3
Engine turns over, fails to start	6-3
Engine backfires	6-3
Engine runs irregularly, stalls or misfires	6-4
Engine runs irregularly, stalls or misfires	6-4
Engine stops or loses power.....	6-5

This section gives practical advice to help you deal with a wide range of problems. Take time to read this section before you ride.

Drive Belt and cover problems

Possible Cause	Solution
Driving the vehicle onto a pickup or tall trailer in high range	Shift transmission to low range during loading of the vehicle to prevent belt burning
Starting out going up a steep incline	When starting out on an incline, use low range or dismount the vehicle (after first applying the park brake)
Driving at low RPM or low ground speed (at approximately 5-10 km/h)	Drive at a higher speed or use low range more frequently. The use of low range is highly recommended for cooler CVT operating temperatures and longer component life
Insufficient warm-up of vehicle exposed to low ambient temperatures	Warm the engine before driving, the belt will become more flexible and prevent belt burning
Slow and easy clutch engagement	Use the throttle quickly and effectively for efficient engagement
Towing/pushing at low RPM/low ground speed	Use low range only
Utility use/plowing snow, dirt, etc	Use low range only
Stuck in mud or snow	Shift the transmission to low range, and carefully use fast, aggressive throttle application to engage clutch. WARNING: Excessive throttle may cause loss of control and vehicle overturn
Climbing over large objects from a stopped position	Shift the transmission to low range, and carefully use fast, brief, aggressive throttle application to engage clutch. Excessive throttle may cause loss of control and vehicle overturn

Possible Cause	Solution
Stuck in mud or snow	Shift the transmission to low range, and carefully use fast, aggressive throttle application to engage clutch. WARNING: Excessive throttle may cause loss of control and vehicle overturn
Climbing over large objects from a stopped position	Shift the transmission to low range, and carefully use fast, brief, aggressive throttle application to engage clutch. Excessive throttle may cause loss of control and vehicle overturn
Belt slippage from water or snow ingestion into the CVT system	Remove the CVT cover, drain the water from CVT
Clutch malfunction	Contact your dealer for inspection of clutch components

Engine doesn't turn over

Possible Cause	Solution
Poor engine performance	Check for fouled plugs or foreign material in gas tank, fuel lines, or throttle. Contact your dealer for service.
Tripped circuit breaker	Reset the breaker
Low battery voltage	Recharge battery to 12.5 VDC
Loose battery connections	Check all connections and tighten
Loose solenoid connections	Check all connections and tighten

Engine pings or knocks

Possible Cause	Solution
Poor quality or low octane fuel	Replace with recommended octane fuel
Incorrect ignition timing	Contact your Segway dealer
Incorrect spark plug gap or heat range	Set gap to specs or replace plugs

Engine stops or loses power

Possible Cause	Solution
Overheated engine	Clean radiator screen and core if equipped Clean engine exterior Contact your dealer

Engine turns over, fails to start

Possible Cause	Solution
Out of Fuel	Refuel
Clogged fuel valve or filter	Inspect and clean or replace
Water is present in fuel	Drain the fuel system and refuel
Fuel valve is out of use	Replace
Old or non-recommended fuel	Replace with new fuel
Fouled or defective spark plug(s)	Inspect plug(s), replace if necessary
No spark to spark plug	Inspect plug(s), verify stop switch is on
Crankcase filled with water or fuel	Immediately Contact your dealer
Overuse of choke	Inspect, clean and/or replace spark plugs
Clogged fuel injector	Clean or replace new fuel injector
Low battery voltage	Recharge battery to 12.5 VDC
Mechanical failure	Contact your Segway dealer

Engine backfires

Possible Cause	Solution
Weak spark from spark plugs	Inspect, clean and/or replace spark plugs
Incorrect spark plug gap or heat range	Set gap to specs or replace plugs
Old or non-recommended fuel	Replace with new fuel
Incorrectly installed spark plug wires	Contact your Segway dealer
Incorrect ignition timing	Contact your Segway dealer
Mechanical failure	Contact your Segway dealer

Engine runs irregularly, stalls or misfires

Possible Cause	Solution
Fouled or defective spark plugs	Inspect, clean and/or replace spark plugs
Worn or defective spark plug wires	Contact your Segway dealer
Incorrect spark plug gap or heat range	Set gap to specs or replace plugs
Loose ignition connections	Check all connections and tighten
Water present in fuel	Replace with new fuel
Low battery voltage	Recharge battery to 12.5 VDC

Engine runs irregularly, stalls or misfires

Possible Cause	Solution
Kinked or plugged fuel vent line	Inspect and replace
Incorrect fuel	Replace with recommended fuel
Clogged air filter	Inspect and clean or replace
Reverse speed limiter malfunction	Contact your Segway dealer
Electronic throttle control malfunction	Contact your Segway dealer
Other mechanical failure	Contact your Segway dealer
Possible Lean or Rich Fuel Mixture Cause	Solution
Low or contaminated fuel	Add or change fuel, clean the fuel system
Low octane fuel	Replace with recommended fuel
Clogged fuel filter	Replace filter
Incorrect jetting	Contact your Segway dealer
Overuse of choke	Inspect, clean and/or replace spark plugs
High fuel octane	Replace with lower octane fuel

Engine stops or loses power

Possible Cause	Solution
Out of fuel	refuel
Kinked or plugged fuel vent line	Inspect and replace
Water present in fuel	Replace with new fuel
Overuse of choke	Inspect, clean and/or replace spark plugs
Fouled or defective spark plugs	Inspect, clean and/or replace spark plugs
Worn or defective spark plug wires	Contact your Segway dealer
Incorrect spark plug gap or heat range	Set gap to specs or replace plugs
Loose ignition connections	Check all connections and tighten
Low battery voltage	Recharge battery to 12.5 VDC
Clogged air filter	Inspect and clean or replace
Reverse speed limiter malfunction	Contact your Segway dealer
Electronic throttle control malfunction	Contact your Segway dealer
Other mechanical failure	Contact your Segway dealer



EMISSION CONTROL SYSTEM

SOURCE OF EXHAUST EMISSIONS7-1
EXHAUST EMISSION CONTROL SYSTEM7-1
CRANKCASE EMISSION CONTROL SYSTEM7-1
NOISE CONTROL SYSTEM.....7-1

SOURCE OF EXHAUST EMISSIONS

The combustion process produces carbon monoxide(CO),oxides of nitrogen(NOx)and hydrocarbons(HC).Control of hydrocarbons and oxides of nitrogen is very important because, under certain conditions, they react to form photochemical smog when subjected to sunlight. Carbon monoxide does not react in the same way, but it is toxic.

EXHAUST EMISSION CONTROL SYSTEM

The exhaust emission control system includes a PGM-F system and oxygen sensor. No adjustments to this system should be made although periodic inspection of the components is recommended.

The exhaust emission control system is separate from the crankcase emission control system.

CRANKCASE EMISSION CONTROL SYSTEM

The engine is equipped with a closed crankcase system to prevent discharging crankcase emissions into the atmosphere. Blow-by gas is returned to the combustion chamber through the air cleaner.

NOISE CONTROL SYSTEM

Do not modify the engine,air intake or exhaust components, in order to meet local noise level requirements.



LIMITED WARRANTY	8-1
REGISTRATION	8-1
EXCLUSIONS-ARE NOT WARRANTED	8-1
LIMITATIONS OF WARRANTIES AND REMEDIES.....	8-2
MAINTENANCE LOG	8-3

LIMITED WARRANTY

SEGWAY TECHNOLOGY CO., LTD gives a LIMITED WARRANTY on components of your new SEGWAY vehicle against defects in parts or workmanship when properly set up and operated in accordance with the recommendations set forth in the SEGWAY Owner's Manual. SEGWAY gives a TWO (2) YEAR limited warranty for use of the vehicle. For commercial use, SEGWAY gives a SIX (6) MONTHS limited warranty. This warranty covers parts and labor charges for repair or replacement of defective parts and begins on the date of purchase by the original retail purchaser.

This warranty is transferable to another owner during the warranty period through a SEGWAY dealer, but any such transfer will not extend the original term of the warranty. The duration of this warranty may vary by international region based upon local laws and regulations.

REGISTRATION

At the time of sale, the Warranty Registration Form must be completed by your dealer and submitted to SEGWAY within ten days of purchase. Upon receipt of this registration, SEGWAY will record the registration for warranty.

EXCLUSIONS-ARE NOT WARRANTED

The following are not warranted under any circumstances:

1. Normal wear and tear.
2. Routine maintenance items, tune-ups, adjustments.
3. Damage caused by failure to provide proper maintenance and/or storage, as described in the Owner's Manual.
4. Damage resulting from removal of parts, improper repairs, service, maintenance, or use of parts not manufactured or approved by SEGWAY or resulting from repairs done by a person that is not an authorized servicing SEGWAY dealer.
5. Damage caused by abuse, abnormal use, neglect or operation of the product in a manner inconsistent with the recommended operation described in the Owner's Manual.
6. Damage resulting from accident, submersion, fire, theft, vandalism or any force majeure.
7. Operation with fuels, oils or lubricants which are not suitable for use with the product. (see the section " Technical parameters of vehicle "on Owner's Manual).
8. Damages from rust, corrosion resulted from salty water or corrosive material.
9. Damage resulting from the racing or any other competitive activity.
10. Damage resulting from the vehicle has been altered or modified in such a way so as to adversely affect its operation, performance or durability, or has been altered or modified to change its intended use.

LIMITATIONS OF WARRANTIES AND REMEDIES

This limited warranty excludes any failures that are not caused by a defect in material or workmanship. This warranty provides no coverage for consumable components, general wear items, or any parts exposed to friction surfaces, stresses, environmental conditions and/or contamination for which they were not designed or not intended, including but not limited to the following items:

- Batteries
- Bearings
- Brake components
- Bushings
- Throttle body components
- Circuit breakers/fuses
- Clutches components
- Coolants
- Drive belts
- Electronic components
- Engine components
- Filters
- Finished/unfinished surfaces
- Hydraulic components/fluids
- Light bulbs/lamps
- Lubricants
- Sealants
- Seat components
- Spark plugs
- Steering components
- Suspension components
- Wheels and tires

This warranty provides no coverage for personal loss or expense, including mileage, transportation costs, hotels, meals, shipping or handling fees, product pick-up or delivery, replacement rentals, loss of product use, loss of profits, or loss of vacation or personal time.

THE EXCLUSIVE REMEDY FOR BREACH OF THIS WARRANTY SHALL BE, AT SEGWAY' OPTION, REPAIR OR REPLACEMENT OF ANY DEFECTIVE MATERIALS, COMPONENTS, OR PRODUCTS. THE REMEDIES SET FORTH IN THIS WARRANTY ARE THE ONLY REMEDIES AVAILABLE TO ANY PERSON FOR BREACH OF THIS WARRANTY. SEGWAY SHALL HAVE NO LIABILITY TO ANY PERSON FOR INCIDENTAL, CONSEQUENTIAL OR SPECIAL DAMAGES OF ANY DESCRIPTION, WHETHER ARISING OUT OF EXPRESS OR IMPLIED WARRANTY OR ANY OTHER CONTRACT, NEGLIGENCE, OR OTHER TORT OR OTHERWISE. THIS EXCLUSION OF CONSEQUENTIAL, INCIDENTAL, AND SPECIAL DAMAGES IS INDEPENDENT FROM AND SHALL SURVIVE ANY FINDING THAT THE EXCLUSIVE REMEDY FAILED OF ITS ESSENTIAL PURPOSE. THE IMPLIED WARRANTY OF FITNESS FOR A PARTICULAR PURPOSE IS EXCLUDED FROM THIS LIMITED WARRANTY. ALL OTHER IMPLIED WARRANTIES (INCLUDING BUT NOT LIMITED TO THE IMPLIED WARRANTY OF MERCHANTABILITY) ARE LIMITED IN DURATION TO THE ABOVE SIX MONTH WARRANTY PERIOD. SEGWAY DISCLAIMS ALL EXPRESS WARRANTIES NOT STATED IN THIS WARRANTY. SOME STATES DO NOT PERMIT THE EXCLUSION OR LIMITATION OF INCIDENTAL OR CONSEQUENTIAL DAMAGES OR ALLOW LIMITATIONS ON THE DURATION OF IMPLIED WARRANTIES, SO THE ABOVE LIMITATIONS MAY NOT APPLY TO YOU IF INCONSISTENT WITH CONTROLLING REGION LAW.

MAINTENANCE LOG

Use the following chart to record periodic maintenance.

VIN	Date	Miles(Km)or Hours	Service item

CONSUMER INFORMATION

CO2 emissions levels statement (for Europe)

This CO2 measurement results from testing over a fixed test cycle under laboratory conditions a(n) (parent) engine representative of the engine type (engine family) and shall not imply or express any guarantee of the performance of a particular engine.

Emissions Certification label (for Europe)

This engine conforms to the Non-Road Mobile Machinery (NRMM) regulation(s) in effect at the time of manufacture.

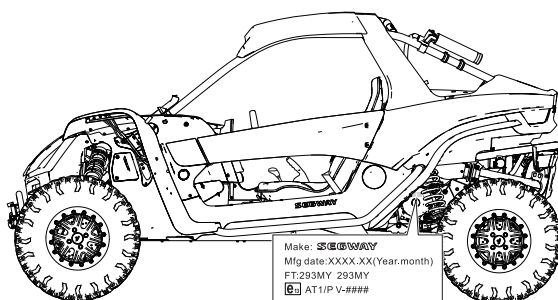

The NRMM regulation limits gaseous and particulate pollution emissions for internal combustion engines of non-road mobile machinery.

Your Segway engine was designed and tested to give an optimal blend of performance without excessive emissions. Therefore, do not attempt to alter the engine specifications or tamper with the intake, engine, or exhaust systems.

⚠ CAUTION

Tampering with the engine or emissions control system will void the European Union typeapproval of this engine.

Noise and vibration levels statement (for Europe)

The figures quoted are emission levels and are not necessarily safe working levels. Whilst there is a correlation between the emission and exposure levels, this cannot be used reliably to determine whether or not further precautions are required. Factors that influence the actual level of exposure of work-force include the characteristics of the work room, the other sources of noise, etc. i.e. the number of machines and other adjacent processes, and the length of time for which an operator is exposed to the noise. Also the permissible exposure level can vary from country. This information, however, will enable the user of the machine to make a better evaluation of the hazard and risk.

CE Declaration of Conformity CE

According to the following Directives

- **Machinery Directive: 2006/42/EC**
- **Electromagnetic Compatibility Directive: 2014/30/EU**

Name of manufacturer or supplier

SEGWAY TECHNOLOGY CO., LTD.

Full postal address including country of origin

No. 395, Xiacheng South Road, Wujin National High-tech Industrial Development Zone, Changzhou, Jiangsu, China

Description of product: Off Road Side by Side Vehicle

Name, type or model

Model: SGW1000F-S4

Standards used, including number, title, issue date and other relative documents

EN 16990:2020 / Side by Side Vehicles – Safety requirements and test methods;

EN 61000-6-2:2005/Electromagnetic compatibility(EMC)-Part 6-2:Generic standards-Immunity for industrial environments;

EN 55012:2007 + A1:2009 / Vehicles, boats and internal combustion engines –Radio disturbance characteristics –Limits and methods of measurement for the protection of off-board receivers

The Technical Construction file is kept at the following EU contact point:

Segway Europe B.V.

Dynamostraat 7, 1014BN, Amsterdam, The Netherlands

Name of authorised representative: Zhukun

Position of authorised representative: General Manager

Declaration

I declare that as the authorised representative, the above information in relation to the supply / manufacture of this product, is in conformity with the stated standards and other related documents following the provisions of the above Directives and their amendments.

Signature of authorised representative *zhukun*

Place: Changzhou, China

Date: 07/01/2021